



Palazzani

INDUSTRIE

PALIFT - DIVISION

RAGNO XTJ 32

USE AND MAINTENANCE MANUAL

Original instructions

RAGNO
SERIAL NUMBER
YEAR OF PRODUCTION
MANUAL N°

XTJ 32 / C
PT 5640
2023
NM 1031

Palazzani

INDUSTRIE

Warning for the users

The contents of this manual are based on know-how, designs, technology applications, used on exclusive basis by Palazzani Industrie SpA, and therefore protected by national and international intellectual property.

Any reference to names, dates and addresses of other Companies is not on purpose and, unless otherwise indicated, it is only an example, to better understand the products made by Palazzani Industrie SpA

The processing of text and images are evaluated with the utmost care, in any case Palazzani reserves the right to modify and / or update the information contained herein, to correct typographical errors and / or inaccuracies, without notice or obligation on the part thereof.

This manual contains all the information necessary for the operators for the normal and planned use of Palazzani products.

The content of this manual is purely technical and owned by Palazzani Industrie SpA.

Any part of this manual may be translated into another language and/or adapted and/or reproduced in another form and/or through any mechanical, electronic, photocopying, recording, etc. tool, without the prior written consent of Palazzani.

The owner Company enforces its rights according to the law.

The documents are prepared in accordance with section 1.7.4 of the CE Directive 2006/42 / CE (Directive on the approximation of the laws of the member states relating to machinery) and in compliance with point 7.1 of EN 280: 2015.

Any request of additional information about the machine, using the specific QR code fixed on the machine.



Palazzani

INDUSTRIE

Palazzani Industrie thanks you for purchasing its product and invites you to read this manual and other attached manuals or documents.

In the manual you will find all needed information for the correct use and service of the supplied machine.

Careful attention to follow the instructions and the reading of this manual in every part is strictly necessary.

You are also invited to contact Palazzani Industrie or a local Dealer directly for spare parts enquiry suggestions on any special equipment choice or, simply, for any indication regarding the ordered machine.

The manual is identified by a unique code, divided into chapters and paragraphs numbered progressively.

Figures are numbered progressively for every chapter and are identified by the description.

The specific equipment instruction manuals are attached to this manual where present. The documents provided with the machine is composed of this Use and Maintenance Manual, the equipment Manual and the Manuals of machines or semi-machines and of the items listed in this documents which are an integral part of the Use and Maintenance Manual and for which the same recommendations/indications of this Manual are valid.

Conformity of the instructions

These warning and use instructions of the machine are conforming to the CE Directive 2006/42/CE, Annex I essential requirement of safety and health 1.7.4.

The following technical standards have been consulted:

EN ISO 12100 Safety of machinery. - General principles for design - Risk assessment and risk reduction.

UNI 10653 Technical documentation - Quality of product technical documentation.

EN 280 : 2015 point 7.1

Pay attention to any different local regulations.

Organisation of the manual

The Machine Instruction and Warnings Manual is organized as follows:

A) General Manual consisting of the following sections:

CAP. 1 : GENERAL CHARACTERISTICS

CAP. 2: SAFETY DIRECTIONS

CAP. 3 : NORMAL WORKING CONDITIONS

CAP. 4 : EMERGENCY CONDITIONS

Palazzani

INDUSTRIE

CAP. 5 : MAINTENANCE AND CHECK

CAP. 6 : ASSIGNMENT OR DEMOLITION OF THE MACHINE

B) Spare parts catalog

C) Instruction manuals drawn up by the respective Manufacturers for the main commercial systems purchased by the Manufacturer and integrated on the machine.

Warranty

The guarantee by Palazzani Industrie S.p.A. covers defects in materials and workmanship.

- **DURATION OF THE WARRANTY:** the warranty covers all repairs of Products carried out within the time limits provided for in the sales contract.
- **OBJECT OF THE GUARANTEE:** the guarantee applies to Products or parts thereof marked with serial numbers or other identification system used by the Company.
- The guarantee is void if unauthorized persons intervene on the supply

The guarantee described above is valid unless otherwise agreed between the Distributor and the Customer.

Instruction Manual scope

The manual, as well as the CE certificate of conformity, is an integral part of machine and must always accompany it even when it is moved or resold. It is owner's responsibility to keep this documentation intact and available to the User, allow consultation, throughout the life of the product itself.

In case of loss or destruction, a copy can be requested from the manufacturer specifying the exact model, serial number and year of production.

The manual reflects the state of the art at the time of supply, the undersigned company reserves the right to make any changes it deems useful to its products, without having to update manuals and systems relating to previous production batches.

This Instruction manual provides all specific information needed for the correct use of your Palazzani machine.

THE PURCHASER MUST MUST HAVE THE CONTENTS OF THE MANUAL READ, MAKE SURE THE SAME UNDERSTANDING, TO ALL PERSONS IN CHARGE OF THE USE AND MAINTENANCE OF THE MACHINE.



Language of the manual



The original manual is in English

Any translations into additional languages must be made starting from the original instructions.

The Manufacturer is responsible for the information contained in the original Instructions; translations into different languages cannot be fully verified, so if an inconsistency is found, it is necessary to follow the original text or contact Palazzani Industrie.

Some symbols are used in the manual to draw the reader's attention and highlight some particularly important aspects of the discussion. The following table describes the meaning of the different symbols used that comply with the EN ISO 7010 standard

SYMBOL	MEANING	NOTE
	Danger	Indicating danger with risk of accident, even mortal, of the staff. Keep the max attention to the texts showing this symbol
	Warning	Indicating warning of possible deterioration or danger to the machine, equipments or other personal object of the customer/user. Keep attention to the text showing this symbol
	Important	Obligation of a special behaviour or activity for a safe machine managing or for information to the staff
	Additional information. Note	The texts including complementary information show this symbol. These information are not directly linked to the description of a function or with the procedure development. They can refer to other complementary documents, such as Instruction Manuals for attachments, technical documents or other sections of the present manual.

Palazzani

INDUSTRIE

Summary

1.	GENERAL CHARACTERISTICS	1
1.1.	INTRODUCTION AND INTENDED USE	1
1.2.	DESCRIPTION	1
1.3.	DIRECTIVE AND RULES	1
1.4.	LIFE CYCLES	2
1.5.	SPECIAL USE	2
1.6.	DIMENSIONS AND PERFORMANCES	3
1.7.	DIMENSIONS	6
1.8.	WORKING AREA	8
1.9.	MAIN GROUPS OF THE PLATFORM	11
2.	SAFETY PRECAUTIONS	12
2.1.	GENERAL SAFETY INFORMATION	12
2.2.	OPERATOR TRAINING AND KNOWLEDGE	13
2.2.1.	<i>PRE OPERATION</i>	13
2.2.2.	<i>MACHINE INSPECTION</i>	14
2.3.	INTENDED USE	16
2.4.	SPECIAL INDICATIONS	16
2.4.1.	<i>ELECTROCUTION HAZARDS</i>	18
2.4.2.	<i>TRIP AND FALL HAZARDS</i>	20
2.4.3.	<i>CRUSHING AND COLLISION HAZARDS</i>	22
2.4.4.	<i>TIPPING HAZARDS</i>	24
2.5.	IMPROPER USE	27
2.5.1.	<i>TOWING, LIFTING, AND HAULING</i>	28
2.6.	MAINTENANCE	28
2.6.1.	<i>MAINTENANCE HAZARDS</i>	28
2.6.2.	<i>BATTERY HAZARDS</i>	30
2.7.	OTHER SAFETY PRECAUTIONS	31
2.7.1.	<i>HANDLING WITHOUT CAGE (FOR MODELS TSJ - XTJ - TZ)</i>	32
2.7.2.	<i>HANDLING WITHOUT CAGE (FOR MODEL TZX)</i>	32
2.8.	ADDITIONAL RISKS, PRECAUTIONS, WARNINGS	33
2.8.1.	<i>Danger for the operator</i>	33
2.8.2.	<i>Residual risks generated by the elements under pressure</i>	33
2.8.3.	<i>Residual risks during maintenance</i>	34
2.8.4.	<i>Explosive atmosphere</i>	34
2.8.5.	<i>Slipping</i>	34
2.8.6.	<i>Stumbling</i>	34
2.8.7.	<i>Circuits failure</i>	35
2.8.8.	<i>Lighting</i>	35
2.8.9.	<i>Risk of heating / burning</i>	35
2.8.10.	<i>Risks due to movement</i>	35
2.8.11.	<i>Risks for the exposed persons</i>	35
2.9.	ADDITIONAL WARNINGS	36
2.10.	OPERATOR'S PROTECTIVE EQUIPMENT	37
2.11.	ENVIRONMENTAL CONDITIONS	39
2.11.1.	<i>Operating environment</i>	39
2.11.2.	<i>Conditions of storage</i>	40



Palazzani

INDUSTRIE

2.12.	SECURITY FUNCTION	40
2.13.	TESTING CERTIFICATE	42
2.14.	TRANSPORT (MODELS XTJ, TSJ, TZ)	43
2.15.	TRANSPORT (MODEL TZX)	47
3.	NORMAL WORK CONDITIONS	49
3.1.	MAIN CONTROL PANEL	49
3.2.	GROUND CONTROL PANEL	50
3.3.	CAGE CONTROL PANEL	51
3.4.	PLATFORM STARTING PROCEDURE	53
3.4.1.	<i>TURRET TRAFFIC LIGHT MANAGEMENT</i>	53
3.5.	USE WITH DIESEL ENGINE	54
3.5.1.	<i>FUNCTIONS POWER AREA</i>	56
3.6.	PLATFORM WORKING WITH ELECTRIC MOTORS	58
3.7.	PLATFORM SELFPROPELLING	60
3.8.	TRACKS ENLARGING (in models where this function is available)	62
3.9.	STEERING	62
3.10.	AUTOMATIC BRAKE	62
3.11.	SPECIAL FUNCTION BUTTON FN	63
3.12.	LEVELING THE MACHINE	65
3.13.	AERIAL WORK	68
3.14.	WORKING AREA AUTOMATIC LIMITING DEVICE	70
3.15.	LOAD LIMITING DEVICE	71
3.16.	CAGE ROTATION	71
3.17.	AUTOMATIC CAGE ORIENTATION	71
3.18.	ELECTRIC CURRENT GENERATOR (OPTION)	72
3.19.	INTERCOM (OPTION)	72
3.20.	MANEUVERS AND GROUND CONTROL PANEL	74
3.21.	MANEUVERS AND CAGE CONTROL PANEL	74
3.22.	SPECIAL DIRECTIONS	75
3.23.	DISPLAY TOUCH SCREEN	76
4.	EMERGENCY CONDITIONS	80
4.1.	DEFINITION	80
4.2.	EMERGENCY CONDITIONS	80
4.2.1.	<i>SAFETY POSITION OF THE CURSOR DURING THE NORMAL USE OF THE PLATFORM (AFTER THE EMERGENCY RECOVERY OF THE PLATFORM).</i>	82
4.3.	PERSONS RECOVERY FROM THE CAGE IN EMERGENCY	84
4.4.	STABILIZERS RECOVERY	90
4.5.	TRAVELLING	91
4.6.	QUICK TROUBLESHOOTING FOR THE OPERATOR	91
5.	MAINTENANCE AND CHECK-UP	93
5.1.	ORDINARY MAINTENANCE - GENERAL INFORMATION	93
5.2.	HYDRAULIC OIL / GREASE FEATURES	94
5.3.	DAILY CHECK	95
5.4.	WEEKLY CHECK	100
5.4.1.	<i>CHECKING AND MAINTENANCE OF THE AIR / OIL HEAT EXCHANGER (ONLY IN MODELS WHERE PROVIDED)</i>	101



Palazzani

INDUSTRIE

5.5.	QUARTERLY CHECK	102
5.6.	SIX MONTH MAINTENANCE	108
5.7.	ANNUAL MAINTENANCE	109
5.8.	FOUR YEAR MAINTENANCE	110
5.9.	EXTRAORDINARY MAINTENANCE	111
5.10.	CHECK OF HYDRAULIC CIRCUIT	113
5.11.	GENERAL ELECTRIC SYSTEM AND BATTERY RECHARGER CHECK	114
5.12.	CHAIN CHECK	116
5.13.	SAFETY DEVICES CHECK	119
6.	PLATFORM ASSIGNMENT AND DEMOLITION	129
6.1.	ASSIGNMENT	129
6.2.	DEMOLITION	129
6.2.1.	<i>WASTE MATERIAL DISPOSAL</i>	<i>129</i>
6.2.2.	<i>INDICATIONS FOR SPECIAL WASTE</i>	<i>130</i>
6.2.3.	<i>DEMOLITION</i>	<i>131</i>
6.3.	CONTROL REGISTER	133
6.3.1.	<i>Storage instructions</i>	<i>133</i>
6.3.2.	<i>Instructions for filling</i>	<i>133</i>

Palazzani

INDUSTRIE

1. GENERAL CHARACTERISTICS

1.1. INTRODUCTION AND INTENDED USE

This equipment is built for lifting people intended as moving people to a working position where they have to do the work from the platform itself, with the intention that people can only get off or on the platform at ground level.

1.2. DESCRIPTION

“Ragno” unit mainly consists of a chassis with 4 articulated stabilizing legs, hydraulically controlled, a turntable slewing on a ball bearing ring.

Steel made multi-telescopic boom is hinged to the turntable and it supports the aerial cage, with an hydraulically articulating jib. All movements are actuated by hydraulic cylinders, or hydraulic motors.

The equipment is supported by rubber tracks or wheels fully integrated into the base chassis. It also has three energy sources: two electric motors and a soundproofed heat engine, alternative to each other and both suitable for the movement of the arms and for the independent travelling of the equipment.

Electro-hydraulic controls in the two position, complementary to each other; the ones on the cage are used for the work movements of the arms, while on the ground, it is possible to travel with the tracks, the placement of the stabilizers and, if enabled, the movements of the arm for the emergency recovery of people.

1.3. DIRECTIVE AND RULES

2006/42/CE Directive indicates the conditions to deliver the machine in EU market. The machine supplied by Palazzani Industrie is a machine complying one of the machines category listed in the Directive attachment IV.

To comply with the conformity of the machine to the Directive dispositions, Palazzani fulfils the risks analysis to verify the respect of safety and health essential subjects indicated in the Directive, further than performing the tests and check required in the applied rules, before delivering the machine.

The manufacture technical report is issued conforming with attachment VII of Directive 2006/42/CE and it is available for the inspecting institutes under justified request, as required by the law dispositions in force.



Palazzani

INDUSTRIE

Palazzani Industrie provides, therefore, to supply the machine to the market, complete of:

- CE Mark
- CE Declaration of Conformity
- Instructions and warning Manual

1.4. LIFE CYCLES

In applying the UNI EN 280: 2015 standard, for the calculation of the fatigue stress, a “heavy duty” application was considered, which translates into a life span of 100,000 load cycles (for example a duration of 10 years, considering 50 working weeks per year, for 40 hours per week and for 5 load cycles per hour).

1.5. SPECIAL USE

In case the machine is needed for special works, or to be used in different conditions in respect to point 1.1, a written approval as authorization by Palazzani Industrie is required. If there is a need to alter the effect of the stability, strength and performance of the platform, written approval by Palazzani Industrie is required

Palazzani

INDUSTRIE

1.6. DIMENSIONS AND PERFORMANCES

Machine in transfer position

Min. height	1985 mm
Length	6900 mm
Width (without cage)	1100/1400 mm
Total weight	5940 kg
Max pressure on the ground of tracks	4.78 kN/m ²
Max. working height	32 m
Max. cage floor height	30 m
Max. outreach	14.3 m
Max cage working load	230 kg (330 kg option)
Max. horizontal pull	400 N
Aerial cage dimensions (A x B)	1800 x 700 x 1100 mm
Min steering radius	4510 mm
Max. selfpropelling speed	3 km/h
Superable slope with outrigger	16 %
Superable slope with tracks	38 %
Turntable slewing	± 330° (360° continuous option)
Cage rotation	90° + 80°
Hydr. system working pressure with diesel engine	220 bar
Hydr. system working pressure with el. motor	170 bar
Max. admitted wind speed	45 km/h
Max. admitted chassis slope	2°

Technical data - times

	DIESEL
Stabilizing legs lifting (to floor touch)	25 sec.
Stabilizing legs lowering	25 sec.
Boom lifting	55 sec.
Boom lowering	50 sec.
Telescopic boom extension	60 sec.
Telescopic boom return	50 sec.
Jib lifting	60 sec.
Jib lowering	60 sec.
Right-left turning (1 turn)	200 sec.

Transfer speed:

10 m slow	55 sec.
10 m fast	10 sec.

Palazzani

INDUSTRIE

Times are considered with empty cage, worm oil and max joystick activation.
A 10% tolerance on this value is acceptable. Times and dimensions are indicative and Palazzani SpA may change the value for internal causes.

Main mechanic components

Tracks type:	MESSERSI RTU 28V
Brakes:	Negative and automatic, with hydraulic releasing
Cage leveling reductor:	RE512 NS20.7 MD30
Turntable rotation motorgearbox:	RE211 NS7.2 MD40

Main hydraulic components

Diesel engine pump	PLP 20.14D0 - 82E2
230V el.motor pump	PLP 20.4D0 - 82E2
Turntable slewing device	ARM30/168F
Proportional electro distributor	DANFOSS

Filters	INLET WITH FULL CAPACITY Filtering 25 micron
---------	---

Hydraulic oil tank	105 liters
--------------------	------------



WARNING

For filling-up, it is recommended to use the above specified oil types exclusively - in case of oils with corresponding characteristics, it is advisable to make a complete change.

Main electric components

Electric motor	3 kW - 230 V a.c.
Generator (option)	5 kW - 230 V a.c.
Battery	N° 2 100 Ah
Battery charger	230 V ac - 12 V dc - 15 A
Radiocontrol	See manufacturer book

Engine	Diesel atmospheric
Brand	Kubota D1105 E4B STAGE V
Fuel	Diesel
Fuel tank	60 liters

Transmission	Neutral
Noise lowering solutions	Original cover made with phonoabsorbing panel
Net power	18.2 kW at 3000 rpm.



Palazzani

INDUSTRIE

Phonometric tests (Directive 2000/14/CE)

Measured sound power level	L _{wA} = 93 dB
Guaranteed sound power level	L _{wA} = 95 dB

Vibrations

Operator hand/arm	< 2,5 m/sec ² di A(8)
Operator body	< 0,5 m/sec ² di A(8)

Gas emissions (exhaust gas)

In compliance with UE regulation 2016/1628 of the European parliament and of the council.

Acceptance tests

Before shipment, the machine was tested in accordance with the provisions of the current EN 280: 2015 standard.

Palazzani

INDUSTRIE

1.7. DIMENSIONS

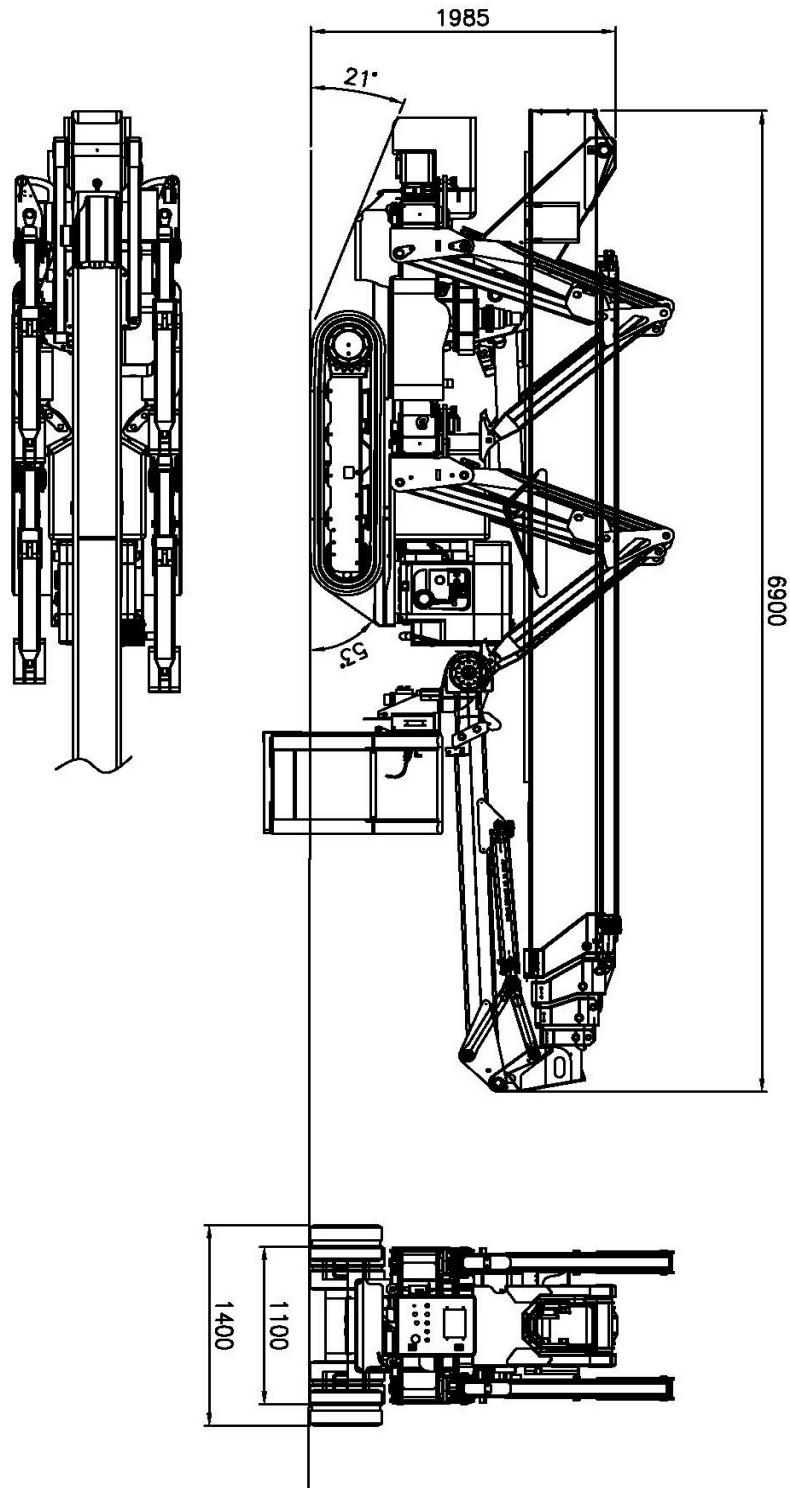

fig 1.1

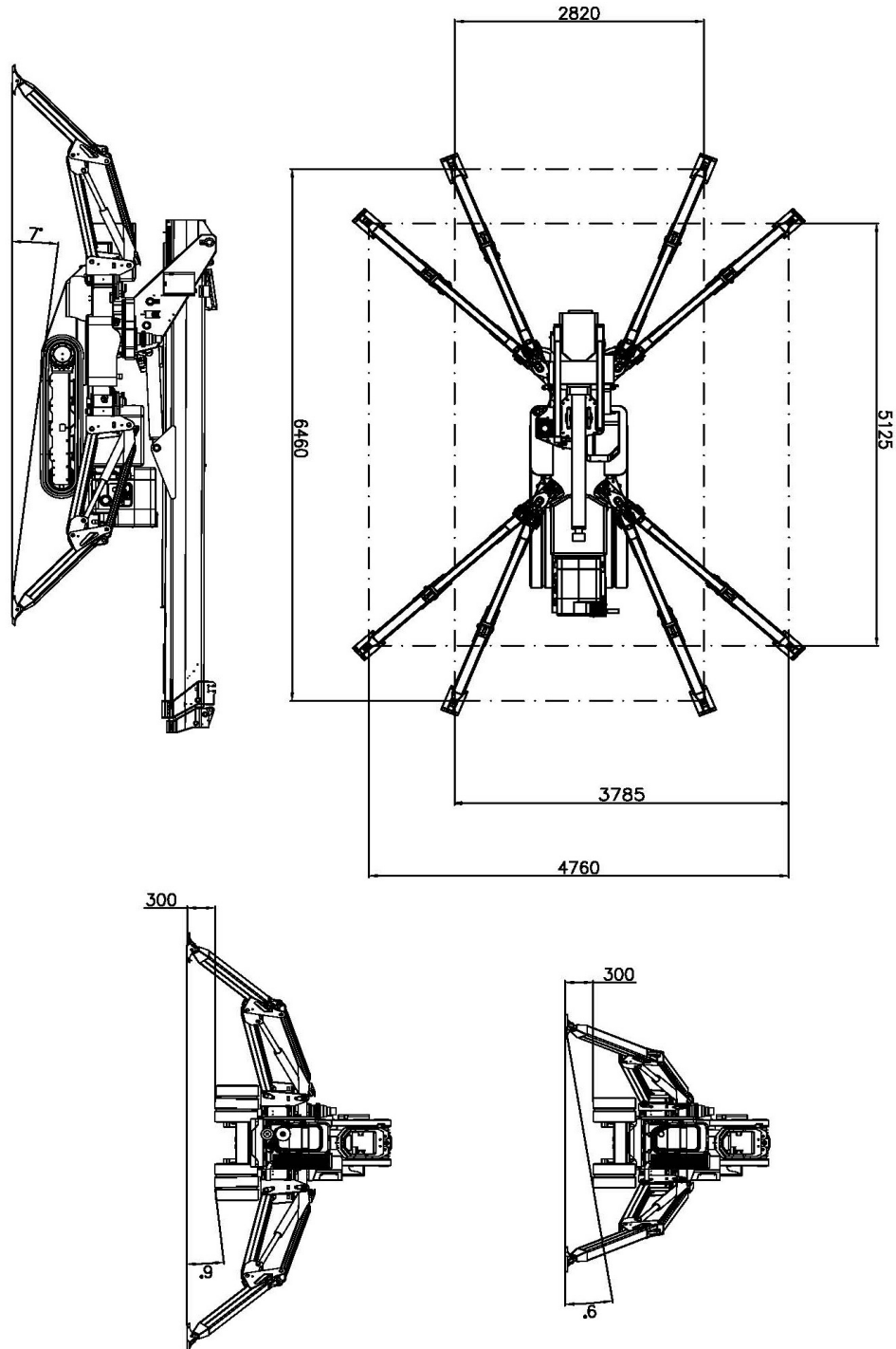

fig 1.2

Max loading on a stabiliser kN 35

Palazzani

INDUSTRIE

1.8. WORKING AREA

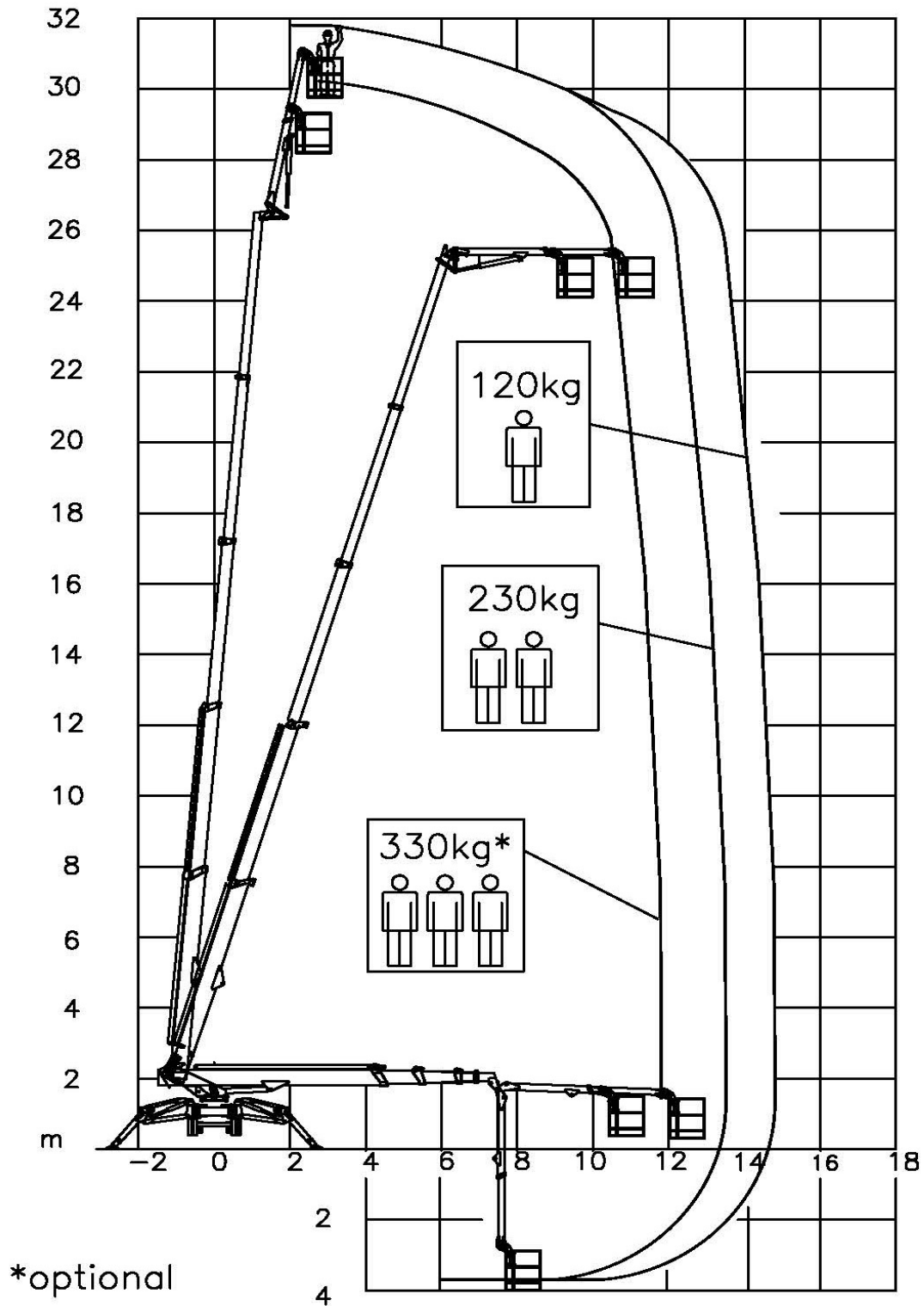

fig 1.3

Palazzani

INDUSTRIE

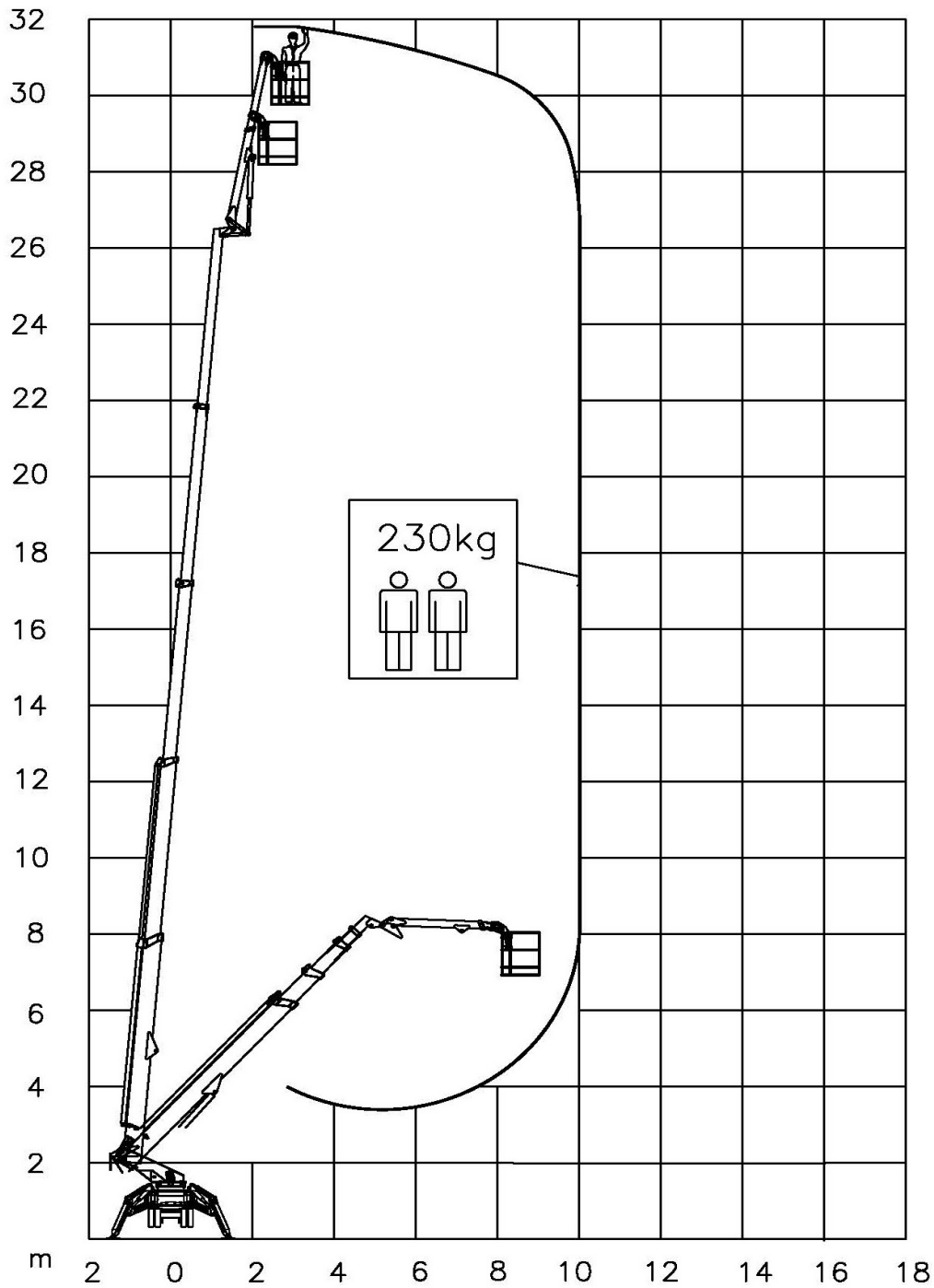

fig 1.3a

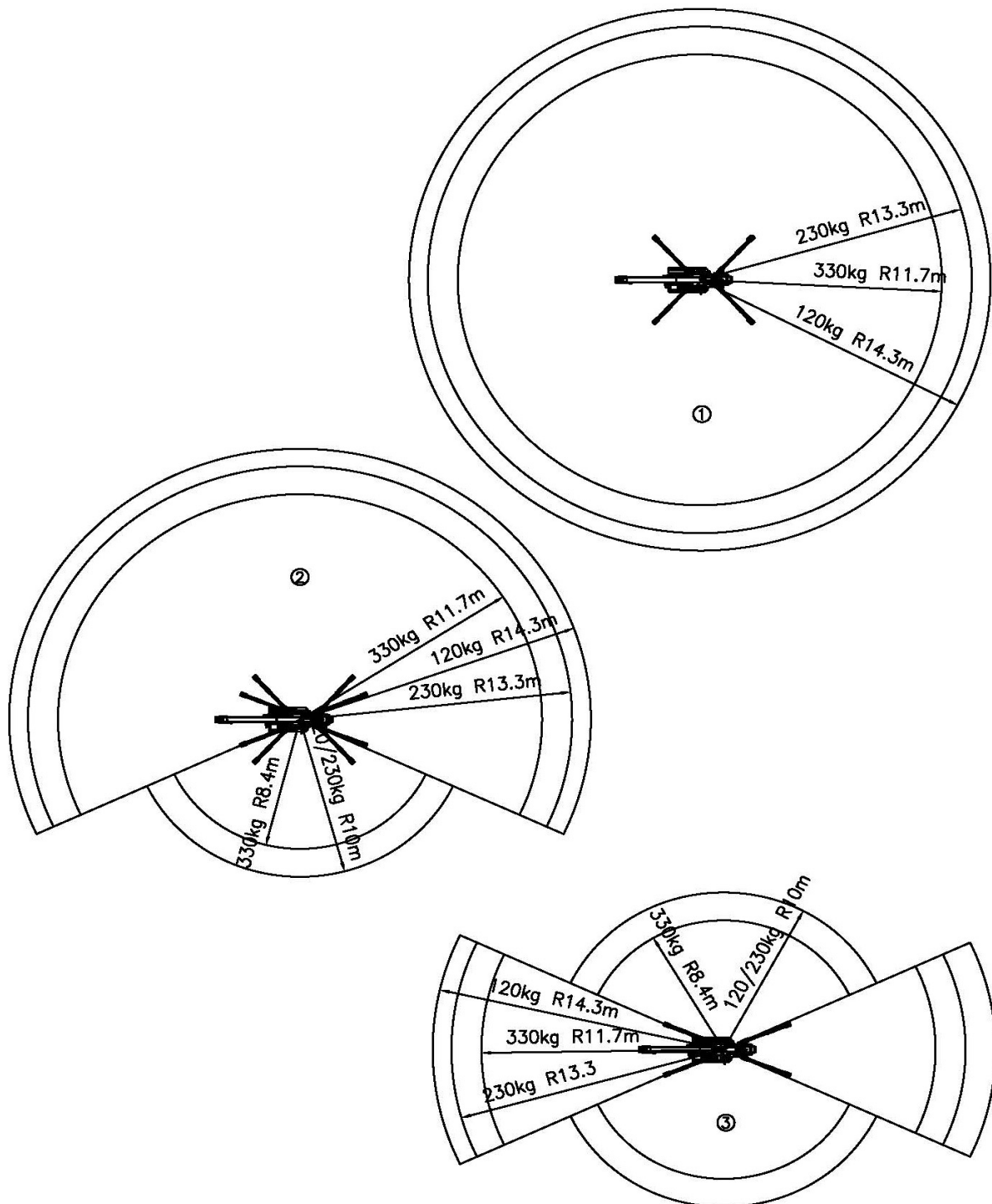

fig 1.4

Palazzani

INDUSTRIE

1.9. MAIN GROUPS OF THE PLATFORM

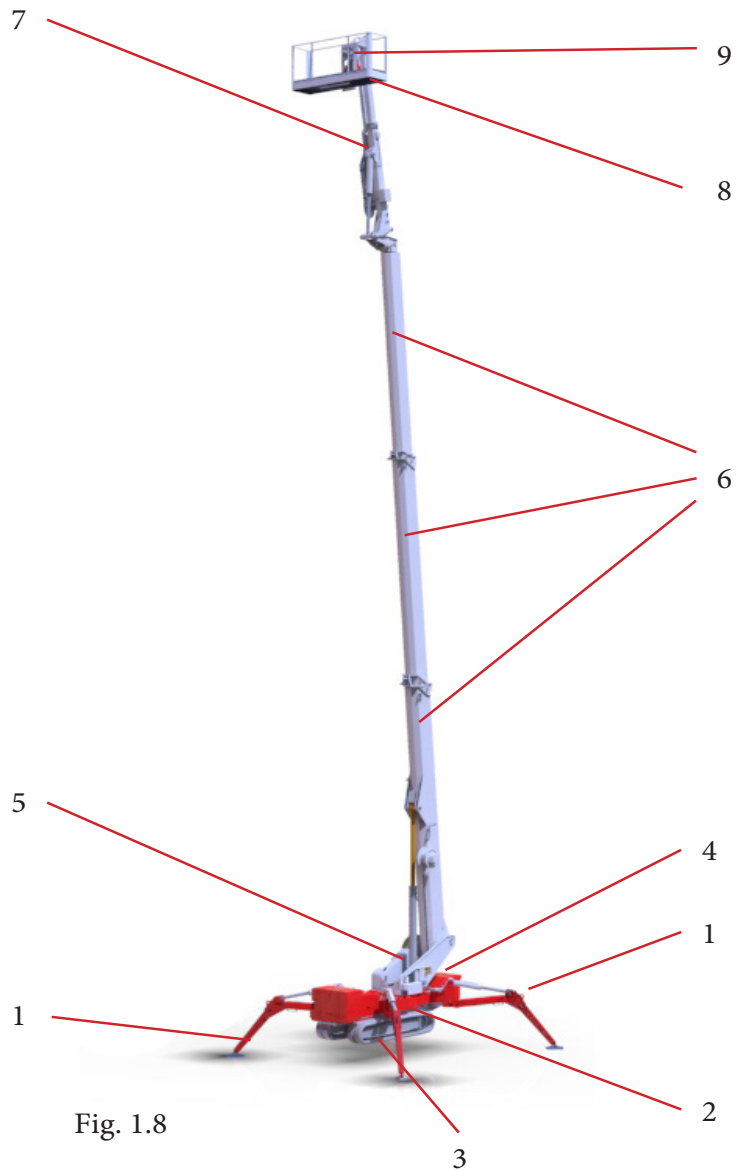

Fig. 1.8

- | | |
|------------------------|------------------------------|
| 1) Stabilizers | 6) telescopic boom extension |
| 2) chassis | 7) jib |
| 3) tracks or wheels | 8) cage |
| 4) main electrical box | 9) cage control panel |
| 5) turret | |

Palazzani

INDUSTRIE

2. SAFETY PRECAUTIONS

2.1. GENERAL SAFETY INFORMATION

The user has the responsibility to provide the personnel all necessary instructions about any possible accident risks, safety devices and general rules about safety in accordance with the EU directives and Country laws where the machine is used.

The authorized personnel must know all position and functioning controls and machine characteristics.

This manual has to be read totally, as well as all attachment which are part of the manual.

In case of any doubt on the correct instructions understanding, contact the manufacturer PALAZZANI INDUSTRIE S.p.A. to get the needed explanations.



ALL PERSONS OPERATING WITH THE MACHINE MUST READ THE INFORMATION IN THIS MANUAL CAREFULLY AND UNDERSTAND, IN PARTICULAR THE SAFETY INSTRUCTIONS LISTED IN THIS CHAPTER.



DANGER

TAMPERING OR NOT AUTHORIZED SUBSTITUTION OF ONE OR MORE PARTS OF THE MACHINE, THE USE OF EQUIPMENTS WHICH MODIFY THE MACHINE USE AND SPARE PART REPLACED WITH DIFFERENT MATERIALS FROM THE SUGGESTED ONE CAN CAUSE ACCIDENT RISK AND ARE FORBIDDEN



WARNING

When the operator performs any movement of the machine, there is a system response delay of about 0.5 seconds.

Palazzani

INDUSTRIE

2.2. OPERATOR TRAINING AND KNOWLEDGE

Operators need to be trained to the use and maintenance by qualified personnel.

This section outlines the necessary precautions for proper and safe machine usage and maintenance. It is mandatory that a daily routine is established based on the content of this manual to promote proper machine usage.

A maintenance program, using the information provided in this manual and the Service and Maintenance Manual, must also be established by a qualified person and must be followed to ensure that the machine is safe to operate.

The owner/user/operator/lessor/lessee of the machine must not accept operating responsibility until this manual has been read, training is accomplished, and operation of the machine has been completed under the supervision of an experienced and qualified operator.

This section contains the responsibilities of the owner, user, operator, lessor, and lessee concerning safety, training, inspection, maintenance, application, and operation.

If there are any questions with regard to safety, training, inspection, maintenance, application, and operation, please contact Palazzani Industrie.



WARNING

FAILURE TO COMPLY WITH THE SAFETY PRECAUTIONS LISTED IN THIS MANUAL COULD RESULT IN MACHINE DAMAGE, PROPERTY DAMAGE, PERSONAL INJURY OR DEATH.

2.2.1. PRE OPERATION

- Read, understand, and study the Operation and Safety Manual in its entirety before operating the machine. For clarification, questions, or additional information regarding any portions of this manual, contact Palazzani Industrie S.p.A.
- Only personnel who have received proper training regarding the inspection, application and operation of MEWPs (including recognition and avoiding hazards associated with their operation) shall be authorized to operate a MEWP.
- Only properly trained personnel who have received unit-specific familiarization shall operate a MEWP. The user shall determine if personnel are qualified to operate the MEWP prior to operation.
- Read, understand, and obey all DANGERS, WARNINGS, CAUTIONS, and operating instructions on the machine and in this manual.

Palazzani

INDUSTRIE

- Ensure that the machine is to be used in a manner which is within the scope of its intended application as determined by Palazzani Industrie.
- All operating personnel must have a thorough understanding of the intended purpose and function of the MEWP controls, including platform, ground and emergency descent controls.
- Read, understand, and obey all applicable employer, local, and governmental regulations as they pertain to your utilization and application of the machine.

2.2.2. MACHINE INSPECTION







- Do not operate this machine until the inspections and functional checks as specified in Section 2 of this manual have been performed.
- Do not operate this machine until it has been serviced and maintained according to the maintenance and inspection requirements as specified in the machine's Service and Maintenance Manual.
- Ensure all safety devices are operating properly. Modification of these devices is a safety violation.

	<p>WARNING MODIFICATION OR ALTERATION OF A MEWP SHALL BE MADE ONLY WITH PRIOR WRITTEN PERMISSION FROM THE MANUFACTURER.</p>
--	---

- Do not operate machines on which instruction or safety signs or stickers are missing or illegible.
- Check the machine for modifications to original components. Ensure that any modifications have been approved by Palazzani Industrie.
- Avoid accumulation of debris on platform floor. Keep mud, oil, grease, and other slippery substances away from footwear and platform floor.

Palazzani

INDUSTRIE

	<p>WARNING THE MACHINE IS FOR PROFESSIONAL USE EXCLUSIVELY</p>
	<p>NOTE THE RULES OF THIS MANUALS CAN NOT COVER PARTICULAR SITUATIONS WHICH CAN OCCUR DURING THE DIFFERENT INSTALLATION AND/OR FUNCTIONAL PHASES</p>
	<p>WARNING Do not carry out any maneuvers if you do not know the reactions generated by the controls.</p>
	<p>WARNING NEVER USE a damaged or modified machine (in respect to the original configuration). In presence of damages or variations in respect to the original configuration, inform immediately the safety responsible about the noticed non-conformity.</p>
	<p>WARNING In case a plate or a safety sticker is worn, damaged or not perfectly readable, inform the safety responsible, who will have to replace them immediately.</p>
	<p>SMOKE IS NOT ALLOWED During the operations, the operator hands must be free from other and dangerous objects, to be reactive in case of need. For this reason, during the machine use smoke is not allowed</p>

Palazzani

INDUSTRIE

2.3. INTENDED USE

This machine is designed and manufactured as aerial work platform, to lift persons to the working sites and let them work from the cage, with the possibility to enter and exit from the cage only from the ground and when booms are not extended.



Fig. 2.1

The platform must be stabilised on compact ground - otherwise it is always recommended to place wooden boards under stabilising-legs, to increase the contact area and to reduce the specific pressure on the ground.

2.4. SPECIAL INDICATIONS

Although the platform is specifically designed for personnel lifting and aerial work, it can be used exclusively by trained operators, working in conformity with general safety standards and following the specific instructions of this manual.



NOTE

Read carefully the directions for use and maintenance.

During sloping transfer, keep the cage towards the slope by keeping away from scarps, landslide zones, deep holes and study the way considering the necessary steering radius.

Use the transfer controls, away from the base machine, by using the belt.

In cold temperatures, start the engine and let the oil warming for 5 min before the first maneuvers which need slow speed.



DANGER

Never go in or out the cage when it is in aerial position or extended.
Enter the cage only when it is in parking position.

Palazzani

INDUSTRIE

! **WARNING**
Before completing the stabilising maneuver, check that the platform is perfectly leveled - 2° max. slope is admitted, as per fig. 2.2 (the bubble must be positioned inside the external ring).

! **DANGER**
Before approaching basements or attic floors, verify if platform weight and legs pressure can be supported.

! **DANGER**
Before moving the boom, verify that nobody is under the platform working area.
For long term operations or where it is possible, delimitate the area where the machine boom operates with some chains and indications plates.

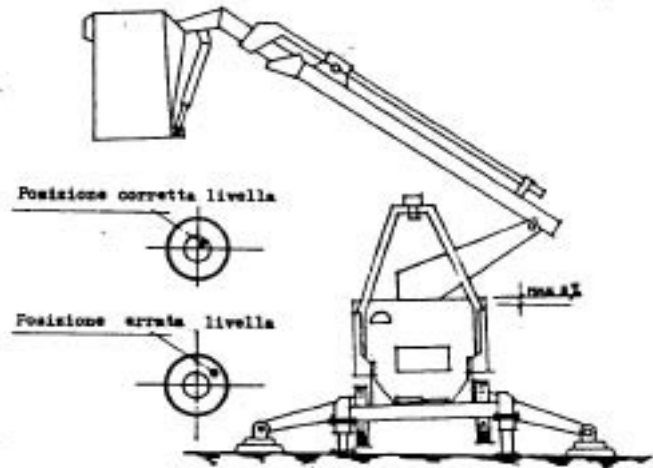

Fig. 2.2

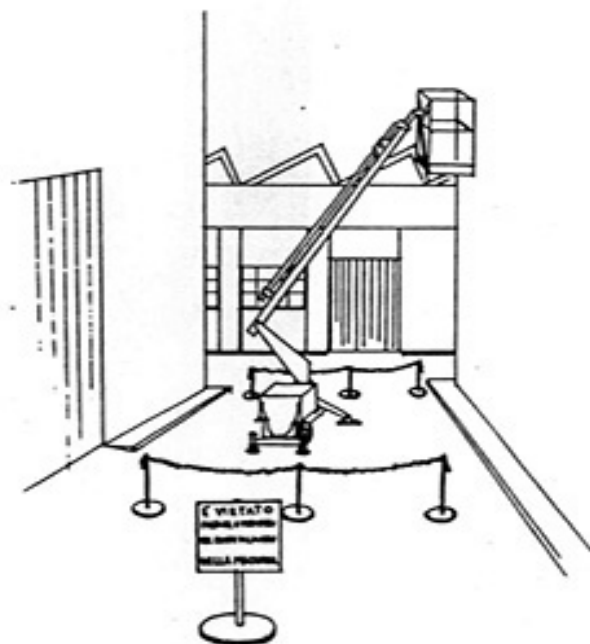

Fig. 2.3

! **WARNING**
Before using the platform, verify the level of the battery.

! **WARNING**
Before using the platform, verify the correct functioning of the safety devices. Inform the technical responsible in case of noise, vibrations or anomalous machine behaviours.

! **DANGER**
Never use the platform as an elevator or to handle persons to different floors.

Palazzani

INDUSTRIE

2.4.1. ELECTROCUTION HAZARDS

This machine is not insulated and does not provide protection from contact or proximity to electrical current.

Keep the distance from electrical lines, equipment or live parts in accordance with the table in Fig. 2.3.a, extracted from Legislative Decree 81/08 and subsequent amendments, Annex IX:

	DANGER
	When working near overhead electric lines, it is necessary to operate with a particular caution, to avoid any accidental contact of the boom or of the cage (Fig. 2.4). Here below the table Minimum Approach Distance.

Un (kV)	D (m)
≤ 1	3
1 < Un ≤ 30	3,5
30 < Un ≤ 132	5
> 132	7

Fig. 2.3a



Fig. 2.4

Fig 2.3.a: Safety distances from active parts of electrical lines and electrical systems that are not protected or not sufficiently protected to be observed, in the execution of non-electrical works, net of the dimensions deriving from the type of work, of the equipment used and of the materials handled, as well as lateral displacements of the conductors due to the action of the wind and lowering of altitude due to thermal conditions.

Palazzani

INDUSTRIE

The minimum approach distance may be reduced if insulating barriers are installed to prevent contact, and the barriers are rated for the voltage of the line being guarded. These barriers shall not be part of (or attached to) the machine.

The minimum approach distance shall be reduced to a distance within the designed working dimensions of the insulating barrier. This determination shall be made by a qualified person in accordance with the employer, local, or governmental requirements for work practices near energized equipment.

	<p>DANGER DO NOT MANEUVER MACHINE OR PERSONNEL INSIDE PROHIBITED ZONE (MAD). ASSUME ALL ELECTRICAL PARTS AND WIRING ARE ENERGIZED UNLESS KNOWN OTHERWISE.</p>
--	--

	<p>DANGER This machine is <u>not</u> electrically insulated. Avoid any contact with electric lines</p>
--	---

For special applications that need the connection to the ground, use the screw on the chassis (Fig. 2.5).



Fig. 2.5

	<p>NOTE Depending on the country , it is owner's responsibility to company with different local safety regulations.</p>
--	--

Palazzani

INDUSTRIE

2.4.2. TRIP AND FALL HAZARDS

Prior to operation, ensure all gates are closed and fastened in their proper position.

During operation, occupants in the platform must wear a full body harness with a lanyard attached to an authorized lanyard anchorage point. Attach only one (1) lanyard per lanyard anchorage point.



WARNING

The lifting persons cage is equipped with hooks for the safety belts for the max number of operators allowed in the cage. The locking points are to be considered as work restraint system, which prevent the operator from falling down the platform and not a fall arrest system which stop the operator from falling down.

Every anchor contact is designed to grant one person only, without succeeding 3 kN static force, within this data no permanent deformations is granted.

Enter and exit only through gate area. Use extreme caution when entering or leaving platform. Ensure that the platform assembly is fully lowered.

Face the machine when entering or leaving the platform.

Always maintain “three point contact” with the machine, using two hands and one foot or two feet and one hand at all times during entry and exit.

Keep both feet firmly positioned on the platform floor at all times. Never position ladders, boxes, steps, planks, or similar items on unit to provide additional reach for any purpose.

Keep oil, mud, and slippery substances away from the platform floor.

Palazzani

INDUSTRIE



DANGER

During the entire stay in the cage, it is forbidden to lift on the footboards, cage sides or any other object to increase the working height; operators must always work with their feet on the cage floor (Fig. 2.7).

It is forbidden also to lean over the cage or, if necessary, it is obligatory to do it maintaining the feet on the cage floors and check that the safety belt is well locked.

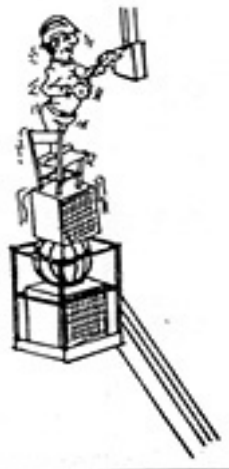

Fig. 2.7



DANGER

Do not throw materials or tools from the cage to the ground and vice versa - use the service rope (fig 2.8).

Unused tools in the cage must be laid on the cage floor, or stowed in special pockets fixed to the cage sides.

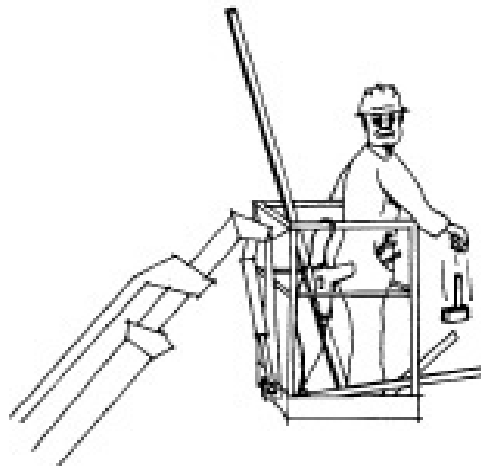

Fig. 2.8

Palazzani

INDUSTRIE

2.4.3. CRUSHING AND COLLISION HAZARDS

Approved head gear must be worn by all operating and ground personnel.

Watch for obstructions around machine and overhead when driving. Check clearances above, on sides, and bottom of platform when lifting or lowering the platform.

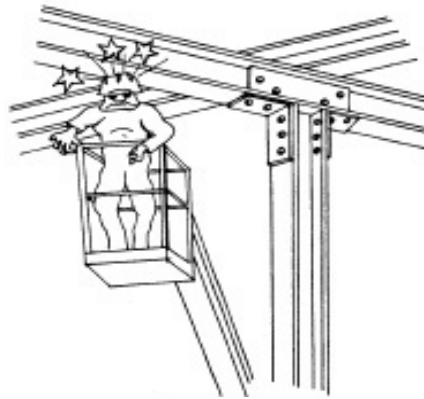

Fig. 2.6

During operation, keep all body parts inside of the cage.

Use the boom functions, not the drive function, to position the platform close to obstacles.

Always find a vantage point when moving the machine in areas where vision is obstructed.

Keep non-operating personnel at least 6 ft. (1.8m) away from machine during all operations.

Under all travel conditions, the operator must limit travel speed according to conditions of ground surface, congestion, visibility, slope, location of personnel, and other factors which may cause collision or injury to personnel.

Pay attention to stopping distances at all driving speeds. When moving the platform at high speed, gradually decrease the speed before stopping.

Do not use high speed drive in restricted or close quarters or when driving in reverse.



Palazzani

INDUSTRIE

Exercise extreme caution at all times to prevent obstacles from striking or interfering with operating controls and persons in the platform.

Ensure that operators of other overhead and floor level machines are aware of the MEWP's presence. Disconnect power to overhead cranes.

Warn personnel not to work, stand, or walk under a raised boom or platform. Position barricades on floor if necessary.

Palazzani

INDUSTRIE

2.4.4. TIPPING HAZARDS

Ensure that the ground conditions are adequate to support the maximum outrigger load indicated on the outrigger load decals located on the machine.

Do not lean on unsupported surfaces.

The user must be familiar with the operating surface before driving. Do not exceed the allowable sideslope and grade while driving.

Do not elevate platform while on or near a sloping, uneven, or soft surface. Ensure that the machine is positioned on a smooth, firm surface within the limits of the maximum operating slope before elevating platform.

Before driving on floors, bridges, trucks, and other surfaces, check allowable capacity of the surfaces.

Do not elevate the platform unless the machine is on a firm operating surface and outriggers are properly set.

Never exceed the maximum platform capacity as specified on the platform. Keep all loads within the confines of the platform, unless authorized by Palazzani Industrie.

Keep the chassis and outriggers of the machine at a minimum of 2 ft. (0.6m) from holes, bumps, dropoffs, obstructions, debris, concealed holes, and other potential hazards at the ground level.

Do not push or pull any object with the boom.

Never attempt to use the machine as a crane. Do not tie-off machine to any adjacent structure. Never attach wire, cable, or any similar items to platform.

Palazzani

INDUSTRIE

Do not operate the machine when wind conditions exceed 28 mph (12.5 m/s).



Refer to Table Beaufort Scale (For Reference Only). Factors affecting wind speed are; platform elevation, surrounding structures, local weather events, and approaching storms.

Beaufort Number	Wind Speed		Description	Land Conditions
	mph	m/s		
0	0	0-0.2	Calm	Calm. Smoke rises vertically
1	1-3	0.3-1.5	Light air	Wind motion visible in smoke
2	4-7	1.6-3.3	Light breeze	Wind felt on exposed skin. Leaves rustle
3	8-12	3.4-5.4	Gentle breeze	Leaves and smaller twigs in constant motion
4	13-18	5.5-7.9	Moderate breeze	Dust and loose paper raised. Small branches begin to move
5	19-24	8.0-10.7	Fresh breeze	Smaller trees sway.
6	25-31	10.8-13.8	Strong breeze	Large branches in motion. Flags waving near horizontal. Umbrella use becomes difficult.
7	32-38	13.9-17.1	Near gale/ Moderate gale	Whole trees in motion. Effort needed to walk against the wind.
8	39-46	17.2-20.7	Fresh gale	Twigs broken from trees. Cars veer on road.
9	47-54	20.8-24.4	Strong gale	Light structure damage.

Palazzani

INDUSTRIE

Wind speed can be significantly greater at height than at ground level.

Wind speed can change rapidly. Always consider approaching weather events, the time required to lower the platform, and methods to monitor current and potential wind conditions.

Do not increase the surface area of the platform or the load. Increase of the area exposed to the wind will decrease stability.

Do not increase the platform size with unauthorized deck extensions or attachments.

If boom assembly or platform is in a position that one or more outriggers are off the ground, all persons must be removed before attempting to stabilize the machine. Use cranes, forklift trucks, or other appropriate equipment to stabilize machine.



DANGER

DO NOT OPERATE THE MACHINE WHEN WIND CONDITIONS EXCEED SPECIFICATIONS SHOWN IN FIGURE 1-2 BEAUFORT SCALE.



DANGER

Do not place flags or large stripes on the aerial cage, which increase the surface exposed to the wind.

Palazzani

INDUSTRIE

2.5. IMPROPER USE

- If not explicitly indicated by the customer and indicated in the Use Manual, it is forbidden to use the platform as a crane, with or without the connected cage
- The strains induced to the frame due to the weigh lifting may cause serious damage to the parts and affect the arms stability itself or the chains endurance.
- It is forbidden to drive the platform, if the boom is not lowered on its rest position. The machine stability may be seriously affected.
- Any modification of the speed of the booms movements is forbidden, in order to avoid vertical and horizontal accelerations exceeding the designed ones
- It is forbidden to mount any superstructure (flags, posters) in the cage, increasing the resistance to the wind in the aerial cage which could overturn or collapse the machine
- It is forbidden to extend the telescopic booms if the wind speed is over 12.5 m/s (45 km/h)

	<p>DANGER Avoid any contact against fixed, or mobile structures (buildings, ect..) or moving objects (cars, ect...)</p>
--	--

	<p>DANGER Never exceed the max admitted safe working load, avoid to load material during work condition. The use of the platform as a crane is forbidden, if not expressly indicated by the manufacturer.</p>
--	--



Fig. 2.10

	<p>DANGER Do not modify the electro hydraulic plant or the regulations to get higher performances.</p>
--	---

Palazzani

INDUSTRIE

2.5.1. TOWING, LIFTING, AND HAULING

- Never allow personnel in platform while towing, lifting, or hauling.
- Ensure that the boom is in the stowed position and the turntable locked prior to towing, lifting or hauling. The platform must be completely empty of tools.
- When lifting the machine, lift only at designated areas of the machine. Lift the unit with equipment of adequate capacity.
- Refer to the Machine Operation section of this manual for lifting information.

2.6. MAINTENANCE

This sub-section contains general safety precautions which must be observed during maintenance of this machine. Additional precautions to be observed during machine maintenance are inserted at the appropriate points in this manual and in the Service and Maintenance Manual. It is of utmost importance that maintenance personnel pay strict attention to these precautions to avoid possible injury to personnel or damage to the machine or property. A maintenance program must be established by a qualified person and must be followed to ensure that the machine is safe.

2.6.1. MAINTENANCE HAZARDS

Shut off power to all controls and ensure that all moving parts are secured from inadvertent motion prior to performing any adjustments or repairs.

Never work under an elevated platform until it has been fully lowered to the full down position, if possible, or otherwise supported and restrained from movement with appropriate safety props, blocking, or overhead supports.

DO NOT attempt to repair or tighten any hydraulic hoses or fittings while the machine is powered on or when the hydraulic system is under pressure.

Always relieve hydraulic pressure from all hydraulic circuits before loosening or removing hydraulic components.

DO NOT use your hand to check for leaks. Use a piece of cardboard or paper to search for leaks. Wear gloves to help protect hands from spraying fluid.

Palazzani

INDUSTRIE

Use only replacement parts or components that are approved by Palazzani Industrie. To be considered approved, replacement parts or components must be identical or equivalent to original parts or components.

Never attempt to move heavy parts without the aid of a mechanical device. Do not allow heavy objects to rest in an unstable position. Ensure adequate support is provided when raising components of the machine.

Do not use machine as a ground for welding.

When performing welding or metal cutting operations, precautions must be taken to protect the chassis from direct exposure to weld and metal cutting spatter.

Do not refuel the machine with the engine running.

Use only approved non-flammable cleaning solvents.

Do not replace items critical to stability, such as batteries or solid tires, with items of different weight or specification. Do not modify the MEWP in any way to affect stability.

Refer to the Service and Maintenance Manual for the weights of critical stability items.



DANGER

MODIFICATION OR ALTERATION OF A MEWP SHALL BE MADE ONLY WITH PRIOR WRITTEN PERMISSION FROM THE MANUFACTURER.

Palazzani

INDUSTRIE

2.6.2. BATTERY HAZARDS

Always disconnect batteries when servicing electrical components or when performing welding on the machine.

Do not allow smoking, open flame, or sparks near battery during charging or servicing.

Do not use tools or other metal objects across the battery terminals.

Always wear hand, eye, and face protection when servicing batteries. Ensure that battery acid does not come in contact with skin or clothing.

	<p>DANGER BATTERY FLUID IS HIGHLY CORROSIVE. AVOID CONTACT WITH SKIN AND CLOTHING AT ALL TIMES. IMMEDIATELY RINSE ANY CONTACTED AREA WITH CLEAN WATER AND SEEK MEDICAL ATTENTION.</p>
--	--

Charge batteries only in a well ventilated area.

Avoid overfilling the battery fluid level. Add distilled water to batteries only after the batteries are fully.

Palazzani

INDUSTRIE

2.7. OTHER SAFETY PRECAUTIONS

- Outcoming the area automatic limits is severely forbidden.
- Manual intervention on the hydraulic controls is allowed exclusively for an intervention in emergency – it is forbidden to follow this procedure for an increase of the performances of the platform.
- The use of the radio control is interlocked by a key switch on the main panel: the radio control must be used for aerial movement only in case of emergency. For what has been said, the remote control must always be at ground level during operation of the machinery and must never be brought onto the work platform (basket) by the operator.
- In case of a failure in the electric plant, the emergency operations will allow every maneuver (see the chapter regarding the emergency operations).
- Platform must be directly controlled by the operator on the aerial cage – operation from the ground is admitted only for particular situations and for emergency interventions (maintenance interventions, machine resetting, staff education, short use with an assistant previously authorized by the responsible person in charge, when persons not prepared are present in the cage).
- When the expanding of the tracks is provided, always maneuvers with extended tracks and narrow them when maneuvering on plain terrain only, for passing trough narrow passages.
- When the platform is driven on irregular ground, with important side slopes (15-20%), lower the outriggers to few cm from the ground to avoid the complete machine overturn.
- Driving on a slope up and down, the cage side of the platform must be always up-hill positioned, lower the speed when you are off road.
- When the platform is stabilized on a garage slope, it is advisable to place wooden boards under the lower legs, avoiding any sliding possibility; make sure that the machine does not slip and operate oblique or upward.

Palazzani

INDUSTRIE

2.7.1. HANDLING WITHOUT CAGE (FOR MODELS TSJ - XTJ - TZ)

In the event that it's necessary to disassemble the basket to go across narrow passages, or to further reduce the height of the equipment, follow the following instructions:

- Release the two upper levers and unscrew the two lower handler.
- Lift the cage and remove it.

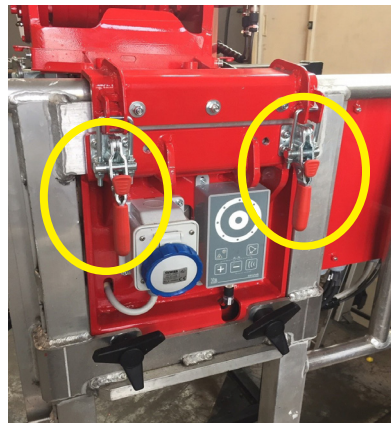

WARNING

When replacing the cage be careful that the two lower handler are completely screwed and the two upper lever are against the cage in order to limiting the cage movement during the machine use.

2.7.2. HANDLING WITHOUT CAGE (FOR MODEL TZX)

- Hook the basket with a forklift or other vehicle, or by hand with two people.
- Unscrew the two safety pins indicated in green color.
- pull the two locking hooks as shows in red color and lift the basket to remove it from its seat.

In order to re-assemble the cage, proceed in the opposite way, checking that the basket is perfectly in place and that the two tie rods are fully inserted. Finally screw in the safety rivets. With the basket removed, no movement of the arm is functional.

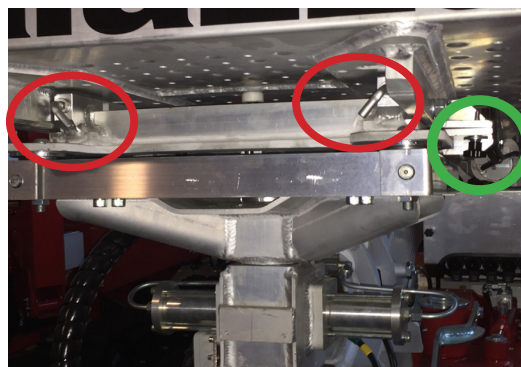

Palazzani

INDUSTRIE

2.8. ADDITIONAL RISKS, PRECAUTIONS, WARNINGS

In the designing phase all parts and areas subject to risks have been evaluated and all necessary precautions have been taken consequently to avoid any risks to persons and damages to the machine components as indicated in the previous paragraphs.

	<p>WARNING</p> <p>PERIODICALLY CHECK ALL SAFETY DEVICES FUNCTIONING. THE MACHINE CAN OPERATE EXCLUSIVELY WITH FIXED AND / OR MOBILE PROTECTIONS ASSEMBLED AND PROPERLY FIXED. DO NOT INTRODUCE EXTRA OBJECTS OR EQUIPMENTS IN THE MACHINE WORKING AREA.</p>
--	--

Although the machine is equipped with the safety systems mentioned above, some risks which can not be eliminated still remain and are reducible by means of corrective actions and correct mandatory operating modes for anyone operating on the machine. Here below a summary of the risks remaining in the machine during:

- Normal functioning
- Adjusting and start-up
- Maintenance
- Cleaning

2.8.1. *Danger for the operator*

During the normal use of the machine, the operator doesn't risk any danger, since the movements which can cause risks conditions are controlled by the electro-mechanic system installed in the machine.

The risks related to:

- operator disattention,
- non-compliance with the information and instructions contained in this manual,
- deliberate tampering of the machine or of the safety devices,
- tampering of fixed and movable guards,

these actions can not find total intrinsic protection, due to the construction type of the machine.

2.8.2. *Residual risks generated by the elements under pressure*

After pressing the emergency stop, all dangerous movements are depressurized, but all hydraulic hoses and cylinders that hold loads, remain under pressure.

Palazzani

INDUSTRIE

2.8.3. Residual risks during maintenance

During the machine maintenance, pay attention to avoid the risk to enjure:

- arms (abrasion on mechanical parts),
- legs (mechanical parts falling if not properly hold),
- eyes (dangers generated by pression flows and elements in tension),
- head (hit with some machine parts).

Read the description in paragraph 2.9.2 carefully, most of all regarding the elements remaining under pressure with the pneumatic energy sectioned.



SHOCK HAZARD

During the troubleshooting or during a maintenance operation, make sure the machine is not connected to electricity, because the risk of electric shock can be caused by direct contact or by indirect contact.



WARNING

Before plugging to electricity, be sure there's no maintenance intervention on and anybody is operating with the machine

2.8.4. Explosive atmosphere

The machine is not designed to work in explosive or classified environments. The machine is not suitable therefore to operate in areas:

- totally or partially explosive
- classified
- in which corrosive atmospheres are present
- in which high concentrations of gas and / or dust are present
- in which high oily concentrations are present in suspension
- with risk of fire deriving from any material or source of ignition.



WARNING

It is strictly forbidden to use the machine in all above mentioned areas

2.8.5. Slipping

Possible lubricants leaking can cause the slipping of operating personnel.



WARNING

Access those area with non-slip and always cleaned shoes; inspect them periodically depending on usage.

2.8.6. Stumbling

The messy deposit of material can typically create a tripping hazard and limitate the partial or total emergency exit in case of need. Ensure the operational areas, transit areas

Palazzani

INDUSTRIE

and emergency exits to be free from obstacles and to fulfil the compliance requirements.

2.8.7. Circuits failure

Because of possible faults, the circuits / control components, the safety components and the power components can partially lose their efficacy with a consequent lowering of the security level:

- periodically check the functioning status of the machine devices/components.

2.8.8. Lighting

The operator must provide an adequate lighting system on the areas of maintenance of the machine and comply with the local laws in force and according to the Directives.

In case of power failure, it is recommended an average illuminance of at least 400 lux. If, for particular and rare maintenance operations, additional lighting may be necessary, also taking into account the extremely rare nature of these operations, it will be the user's responsibility to provide by means of portable safety lamps (powered at 24 Vdc , not included in the supply).

No standard lighening is supplied with the machine.

2.8.9. Risk of heating / burning

Due to the temperature present on engines there is a potential risk of burn during the normal use and in particular during their maintenance operations.

- Inform the maintenance staff about the maintenance activities or machine use.
- Access those areas waiting the above mentioned parts cooling before and with proper protecting gloves, with the max attention.

2.8.10. Risks due to movement

The machine loading/unloading operations by means of lifting equipments, from container to the box, expose the operators to the risks of suspended loads or crush.

Those operations must be executed exclusively by specialized staff for lifting equipments use, properly trained on that scope.



WARNING

Before operating, read carefully chapter 3 of the manual

2.8.11. Risks for the exposed persons

The exposed persons are third persons not engaged in the machine operation, therefore persons working near the machine or visitors.

During the machine use and maintenance, fence all the working area exposing eventually prohibiting plates

Palazzani

INDUSTRIE



STOP

Keep exposed persons at a safety distance from the dangerous areas

2.9. ADDITIONAL WARNINGS



DANGER

The hydraulic flow at high pressure output can cause damage to things and people.

Make sure all connections to the fluidic circuit are well connected and tightened to the hydraulic drives through pipes and fittings certified and suitable for the pressures.



DANGER

During the machine operation and maintenance, wear helmets, safety shoes, protective gloves, protective clothing and safety glasses complying with the essential safety requirements set by EU Directives 89/656 / CEE and 89/868 / CEE and applicable laws in the country where it is required / used



DANGER

Never perform any routine or extraordinary maintenance with the hydraulic energy circuits in pressure and even less with electricity connected. Disconnect all power supply circuits always in advance.



DANGER

Following the disconnection of the power supplies, ensure that there are no residual pressure in the circuit. Always release the residual pressure.



WARNING

Ensure that all personnel involved in the maintenance and use of the machine is properly trained in accordance with the correct procedures on safety and operation.

Ensure that all personnel is aware of the residual risks arising from the use of the machine.

Palazzani

INDUSTRIE

	<p>WARNING</p> <p>Ensure that all protective devices are connected and in good function. Never modify or bypass any safety devices of the machine.</p>
	<p>WARNING</p> <p>Both during the maintenance and operational phases it is recommended to pay attention to the temperature of engines that can be more than 50 ° C in normal operation.</p>
	<p>WARNING</p> <p>The machine can not be used by unprofessional staff, or not previously trained to the use, informed about the remaining risks of the machine and trained on safety and correct operating methods.</p>
	<p>DANGER</p> <p>Do not use the machine in aerial work when the wind speed exceeds 12.5 m / s (45 km / h)</p>

2.10. OPERATOR'S PROTECTIVE EQUIPMENT

For operator safety reasons, PPE (or other available equipment) are compulsory for the use of the machine.

The manufacturer requires the customer to use the machine with PPE complying with Directive 89/686 / CEE as amended, relating to personal protective equipment properly CE marked.





The operator must comply with Directive 89/656 / CEE defining the methods of use of personal protective equipment at work.

Since all contexts where the machine work are not known, it must be underlined that the above mentioned PPE refer only to the use of the machine: the employer must prescribe any additional PPE in accordance with the needs of the environment in which the machine operates.

Depending on the country , it is owner's responsibility to comply with different local safety regulations.

Palazzani

INDUSTRIE

PPE for the operator and maintenance staff		
Identifying symbol	Description	Note
	SHOES	Constant use of safety shoes as required by the safety rules in force
	SUITABLE CLOTHING	Suitable clothing , such as working suit: it is forbidden to wear wide sleeves, ties and clothings which can easily catch the elements in movement.
	PROTECTIVE GLOVES	Protective gloves for hands, to handle waste materials manually
	HELMET	Protective helmet to use during the machine lifting operation and preventing any risks of crush by suspended loads

	<p>WARNING</p> <p>Use gloves with attention. The gloves can become a source of risk as they can get caught in any moving parts.</p>
---	--

	<p>WARNING</p> <p>If headphones are used, the operator must pay even more attention as one of the senses of perception of danger (hearing) fails. Please observe the surrounding environment, since visual perception must compensate the hearing loss.</p>
---	--

Palazzani

INDUSTRIE

2.11. ENVIRONMENTAL CONDITIONS

2.11.1. Operating environment

The machine is designed to work both indoors and outdoors, thus subjected to normal atmospheric phenomena.

The limits of use are:

Environment temperature:	min -10°C max 40°C
Relative humidity:	min 5% max 90% without condensate
Altitude:	6562 m
Max wind speed:	12 m/s (45 km/h)
Floor vibrations:	none

The use of the machine, of its control systems and equipment operated under different conditions than those listed is not allowed.

In particular, the work and use environment must not present:

- Exposure to corrosive fumes;
- Exposure to abrasive dust;
- Exposure to explosive mixtures of dust or gas;
- Exposure to salted air;
- Exposure to vibration, shock or abnormal shocks;
- Presence of nuclear radiation, ionizing.



WARNING

If the ambient temperature is below 5° C, before any movement, run the engine for a few minutes.
Start moving the platform with small movements to heat up the hydraulic oil.



DANGER

Before any movement, check that the safety limit switches and emergency stop buttons are clean and free from snow or ice



WARNING

Protect the ground control panel from rain and snow. When the cage controls are not used, especially in rainy days, keep the protective cover closed.

Palazzani

INDUSTRIE

2.11.2. Conditions of storage

The machine must be stored in environments without:

- Exposure to corrosive fumes;
- Exposure to abrasive dust;
- Exposure to explosive mixtures of dust or gas;
- Exposure to salted air;
- Exposure to vibration, shock or abnormal shocks;
- Presence of nuclear radiation, ionizing.

Particularly:

Environmental temperature:	min -30°C max 60°C
Relative humidity:	min 5% max 90% without condensate
Altitude:	2000 m
Floor vibrations:	none



IMPORTANT

After a long period of inactivity of the machine or in the event of a significant change in the environmental conditions of operation / storage at first use check all the safety devices listed in chapter 5.



DANGER

It's not recommended a long storage time of the machine near the marine zone.

2.12. SECURITY FUNCTION

In compliance with the UNI EN ISO 13849-1:2016 standard, the machine control system includes the following safety functions:

- Prevent travel of pedestrian controlled MEWPs – to achieve the PL = d, a combination of safety related parts of control system (SRP/CS) of the appropriate categories according to the UNI EN 280:2015 standard have been selected;
- Monitoring of stabilizers (1) – to achieve the PL = d, a combination of safety related parts of control system (SRP/CS) of the appropriate categories according the UNI EN 280:2015 standard have been selected;
- Monitoring of stabilizers (2) – to achieve the PL = d, a combination of safety related parts of control system (SRP/CS) of the appropriate categories according to the UNI EN 280:2015 standard have been selected;

Palazzani

INDUSTRIE

- Control or lock of tilting – to achieve the PL = d, a combination of safety related parts of control system (SRP/CS) of the appropriate categories according to the UNI EN 280:2015 standard have been selected;
- Load sensing system – to achieve the PL = d, a combination of safety related parts of control system (SRP/CS) of the appropriate categories according to the UNI EN 280:2015 standard have been selected;
- Position control – to achieve the PL = d, a combination of safety related parts of control system (SRP/CS) of the appropriate categories according to the UNI EN 280:2015 standard have been selected;
- Levelling system – to achieve the PL = d, a combination of safety related parts of control system (SRP/CS) of the appropriate categories according to the UNI EN 280:2015 standard have been selected;
- Interlocking of exchangeable work platform – to achieve the PL = c, a combination of safety related parts of control system (SRP/CS) of the appropriate categories according to the UNI EN 280:2015 standard have been selected
- Interlocking of control positions – to achieve the PL = c, a combination of safety related parts of control system (SRP/CS) of the appropriate categories according to the UNI EN 280:2015 standard have been selected;
- Emergency stop function (for independent function) – to achieve the PL = c, a combination of safety related parts of control system (SRP/CS) of the appropriate categories according to the UNI EN 280:2015 standard have been selected;
- Load sensing system (crane version) – to achieve the PL = d, a combination of safety related parts of control system (SRP/CS) of the appropriate categories according to the UNI EN 280:2015 standard have been selected.

Performance levels required PLr as Table 5 – Performance levels for safety functions UNI EN 280:2015.

The UNI EN 280:2015 standard allows the adoption of a category 2 architecture instead of category 3 where the requirements set out in point J.1.2 of appendix J of the standard are met in addition to the related requirements of EN ISO 13849-1.

These requirements are met.



2.13. TESTING CERTIFICATE

That the visual inspections, functional checks and load tests to validate the compliance of the aforementioned aerial working platform (from now on called AWP) to the essential health and safety requirements of the Machinery Directive, to the corresponding documentation and service schemes carried out according to point 6 of EN 280: 2015.

All load diagrams listed in the machine documentation are valid, the limiting and indicator device (where present) has been tested and adjusted for correct operation according to the identified nominal capacities.

Load tests were performed with the maximum test loads in accordance with point 6 of EN 280: 2015.

The load tests have been performed on samples of configurations and the selection of these samples by the manufacturer ensures that all relevant components of the AWP have been subjected to the maximum loads in the conditions that may arise when the AWP is used in the intended manner.

The following table shows the tested configurations to provide information for the periodic inspection.

After the tests, the AWP has been carefully examined. Visual inspection, functional checks, load tests and the examination itself have been supervised by a manufacturer's expert.

Rollover stability tests were performed for all load and stabilizers set-up configurations.

Any result limiting the safe use of AWP has been found.

Palazzani

INDUSTRIE

2.14. TRANSPORT (MODELS XTJ, TSJ, TZ)

“Ragno” platform is authorized to road circulation, only under particular conditions and, therefore, it must be transported by lorry.



WARNING

The machine has no homologation for traffic road circulation.
Check for any further restrictions given by local rules / standards.



WARNING

Always keep a safe distance when moving the machine.

Loading\unloading operations are possible with loading ramps.

The loading ramps must have an adequate load capacity for the machine and sufficient length to not exceed the max. slope admitted to the previous point 1.6 chap.1.

It is suggested to load the machine with the cage towards up, to get better stability and to avoid diesel engine fuel. Since the fuel suction is positioned in the rear side of the machine, in case the ramp is faced with the cage toward down, the machine would be unstable, the eventual lack of fuel could stop the engine.

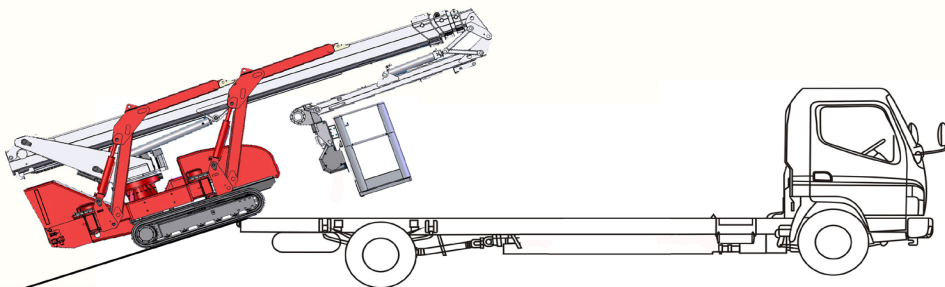

Fig. 2.12

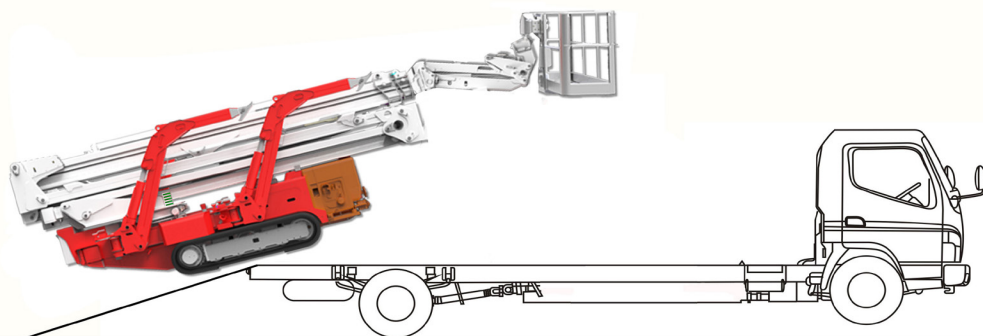

Fig. 2.12a

Palazzani

INDUSTRIE

To drive to the ramp, lift the cage to avoid any contact against the ramp, as shown in drawing 2.12 and 2.12a. See the cage lifting without stabilization procedures, indicated in the paragraph 3 (button FN).

When the machine is in the truck bed, fix it to the lorry bed eyes bolts, by means of 4 turnbuckles as in Fig. 2.13 and 2.13b, and fix the boom and jib using one belt like showed in Fig. 2.13a and 2.13b.

	<p>WARNING During transport, lock the slewing gear rotation with the proper pin indicated in chapt. 3.</p>
--	---

	<p>WARNING When transporting the machine on the truck, it is forbidden to place the jib / arm on any type of support. If necessary, it is advisable to contact Palazzani Industrie S.p.A.</p>
--	--

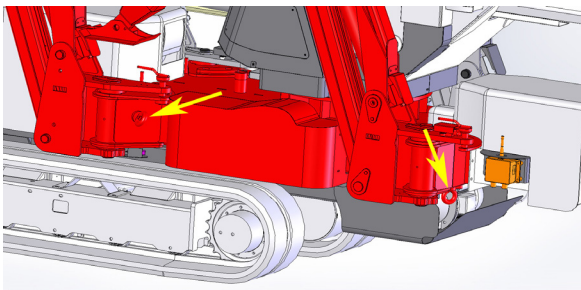

Fig. 2.13

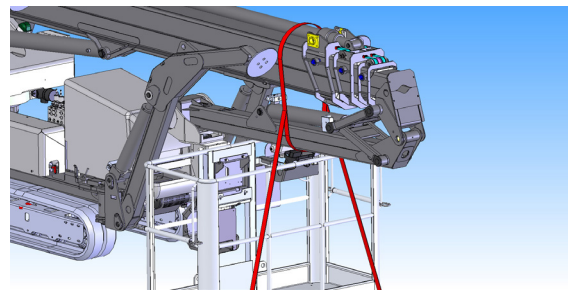

Fig. 2.13a

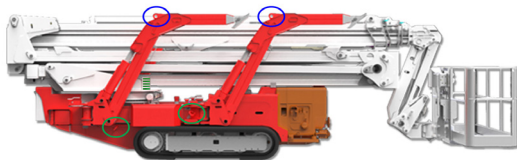

Fig. 2.13b

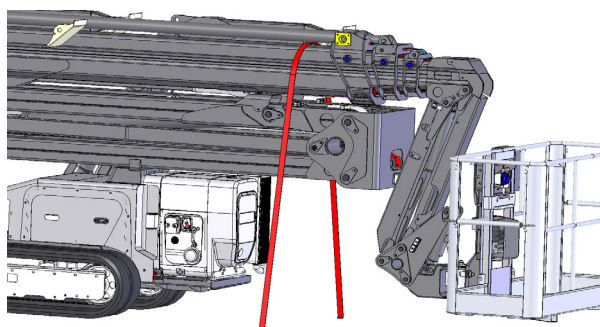

Fig. 2.13d

Palazzani

INDUSTRIE

ONLY IN MODELS WHERE PROVIDED

When transporting the machine, it is obligatory to lock the stabilizer pins, front and rear, using the respective brackets.

It is sufficient to lift the ring and insert the locking pin inside the support (fig 2.15 and 2.15a).

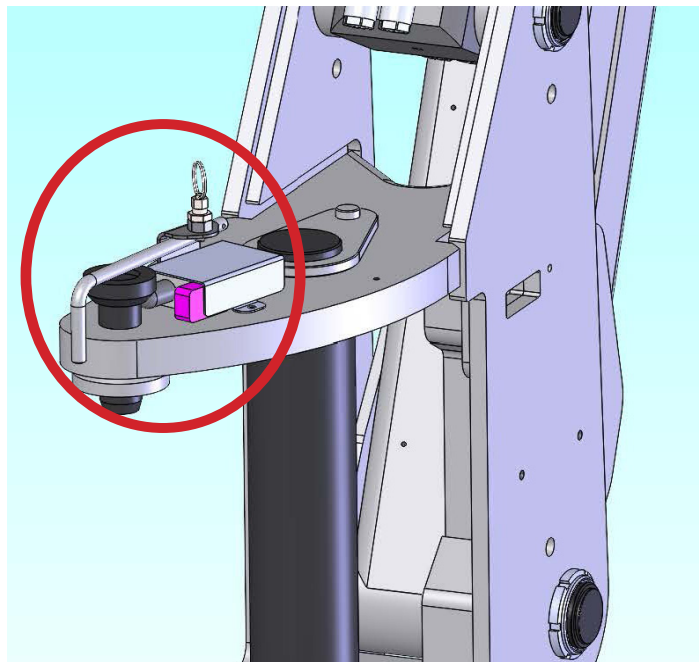

fig 2.15

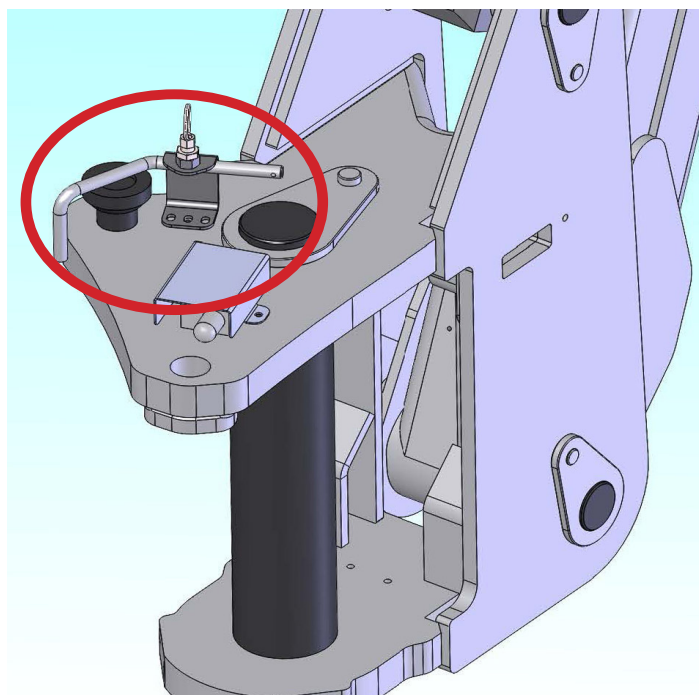

fig 2.15a

Palazzani

INDUSTRIE

With crane:

- using a 4-arms harness of proper capacity and length, fix the hooks in the holes on top of the stabilizers (Fig. 2.14 and 2.14a).
- lift the machine for load or unloading.
- The logistic personnel must be trained persons, instructed about the loading/unloading of the machine. Proper procedures and tools must be used for a safe lifting operation.



WARNING

Strictly follow the indications and warning here below to grant stability and to avoid any risk related to the machine handling.

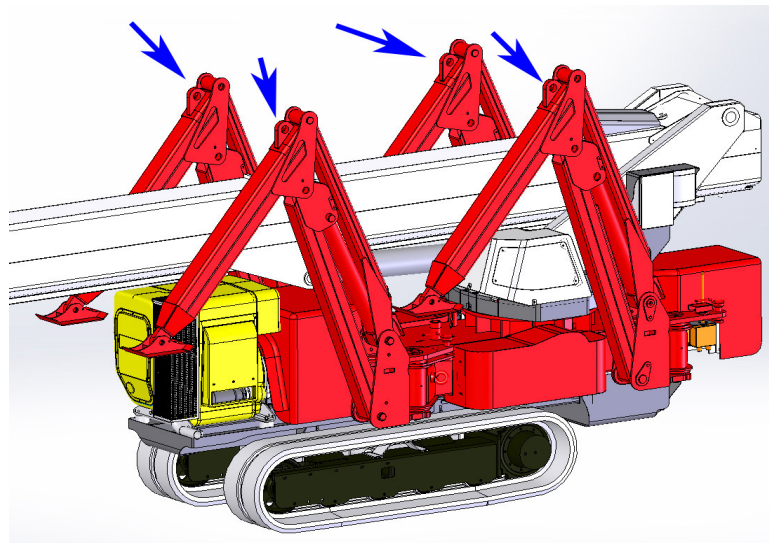

Fig. 2.14

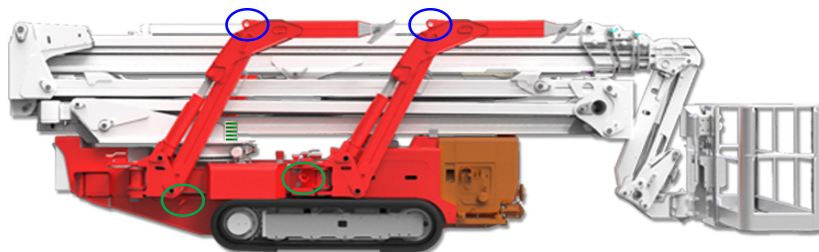

Fig. 2.14a

Palazzani

INDUSTRIE

2.15. TRANSPORT (MODEL TZX)

The Ragno equipment is not allowed to circulate on the road, excepting particular conditions as described in the appropriate paragraph, and thus the machine always has to be carried by lorry.

Load and unload from the lorry, can be execute by means of a crane of adequate rated load or by means of a ramp.

If you use a crane, fix four hardness with hook to the ring on the base of the stabilizers.

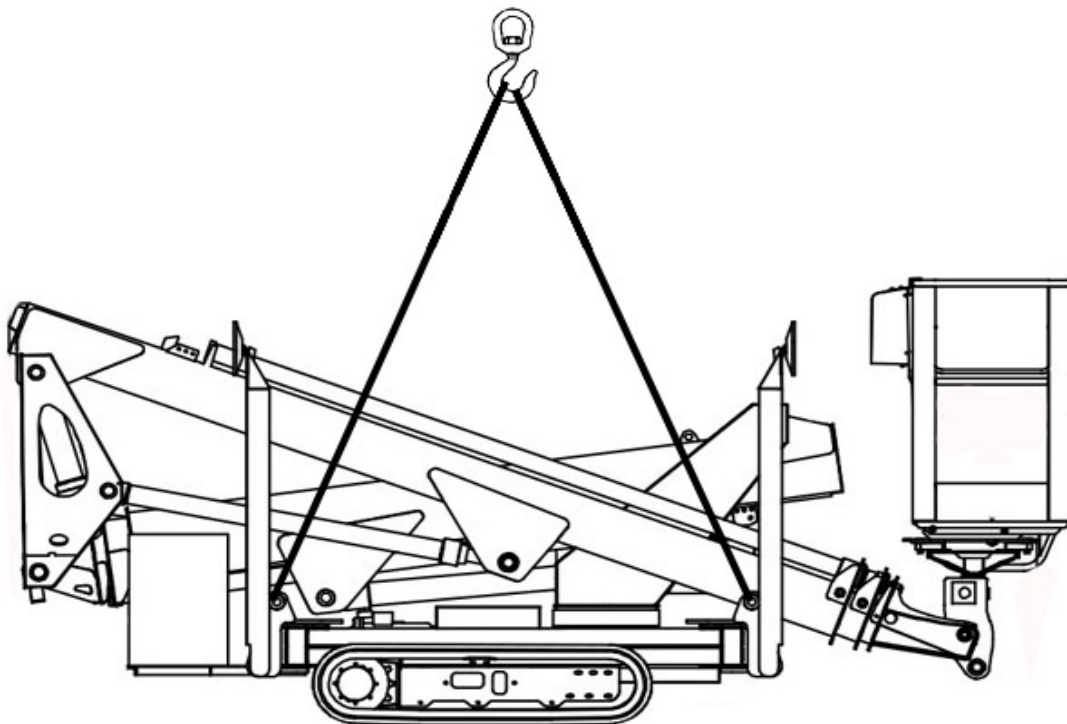

Once the equipment has been loaded onto the truck, it is a good idea to put wedges in front of and behind the tracks, pass a textile rope around the arm and fasten it to the sides on the truck bed winches.



WARNING

When transporting the machine on the truck, it is forbidden to place the jib / arm on any type of support. If necessary, it is advisable to contact Palazzani Industrie S.p.A.

Palazzani

INDUSTRIE

Do not operate any maneuver if not authorized by skilled personnel

- Important: use ropes or chains of proper capacity according to the machine weight
- Attention do not stay under suspended loads

	<p>Note machine lifting/handling operations must be fulfilled exclusively by specialized and trained personnel, skilled to the loads handling.</p>
--	---

	<p>DANGER BEFORE THE MACHINE USE, CHECK THE STATUS AND THE CORRECT FIXING OF THE MACHINES AND OF LIFTING EQUIPMENTS. USE HARNESS AND PROPER EQUIPMENT.</p>
--	---



Wear safety gloves obligatorily



Wear safety shoes obligatorily

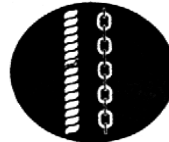

Always check ropes and chains before using. A periodic check is necessary in any case.



It is forbidden staying under suspended loads

	<p>WARNING If obstacles or anything don't allow a perfect visibility during maneuvers, extra personnel must be present out of the lifting machine action, to give indications.</p>
--	---

	<p>DANGER NEVER STAY UNDER THE SUSPENDED LOADS. NEVER HANDLE THE LOAD OVER PERSONNEL OPERATING IN THE WORKING SITE/FACILITY.</p>
--	---

Palazzani

INDUSTRIE

3. NORMAL WORK CONDITIONS

3.1. MAIN CONTROL PANEL



fig 3.1

1. Main key	2. Movements selector
3. Display	4. Battery lamp
5. Oil lamp	6. Spark plug lamp
7. Buzzer engine oil temperatur	8. Emergency pump button
9. FN button	10. Type of stabilization selector
11. Rapid stabilization selector	12. Emergency stop
13. Open-Close track	14. Not used
15. System allarm / max outreach lamp	

Palazzani

INDUSTRIE

3.2. GROUND CONTROL PANEL

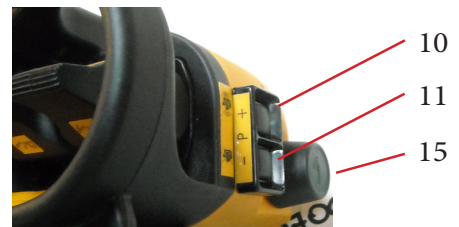
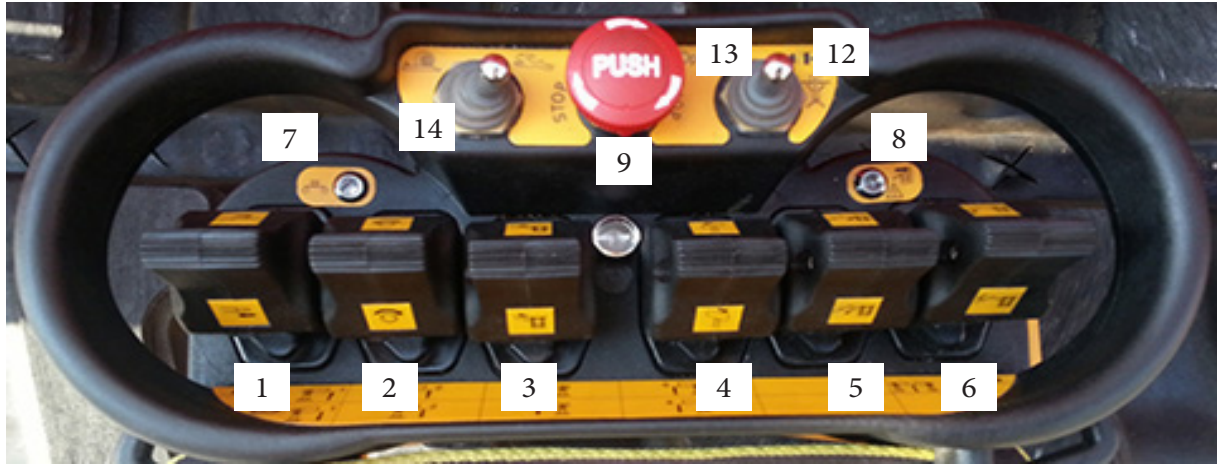

To take a frequency: Turn ON the remote transmitter from the selector 15 and move the selector 12 to the right for 2-3 times.

1. Joystick boom extension/return – stabilizer 1- left track
2. Joystick turntable rotation - stabilizer 2
3. Joystick jib extension/return - stabilizer 3
4. Joystick cage rotation - stabilizer 4
5. Joystick jib opening / closing
6. Joystick boom lifting / lowering - proportional stabilizers – right track
7. Control activation lamp
8. Limiter activation / system alarms lamp
9. Emergency button
10. Start diesel engine
11. Stop diesel engine
12. Self-centering switch - back to home (option) / radio frequency activation
13. Slow/fast transfer switch (speed change: option)
14. Slow/fast transfer switch (engine rpm)
15. Radiocontrol activation switch
16. Active acustic signal (10 sec.)



WARNING

The remote control must only be used for travel and emergency commands.

Palazzani

INDUSTRIE

3.3. CAGE CONTROL PANEL



fig 3.5

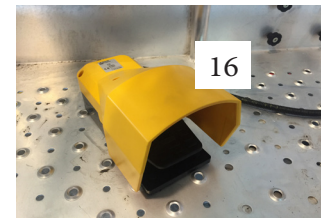

1. Start diesel engine button
2. Stop diesel engine button
3. Generator selector (option)
4. Self- centering button - Back to home button (option)
5. Cage rotation selector
6. Joystick turntable rotation - boom extention/return
7. High weight range lamp
8. Control activation lamp
9. System error / max. outreach lamp
10. Cage overload lamp
11. Boom lifting/lowering joystick - jib opening/closing
12. Emergency button
13. Extended/retracted jib button
14. Not used
15. Start generator lamp
16. Active movements (option)



Information

To activate the controls of the aerial movements from the basket, the operator must press one of the two buttons located above the joysticks 6 and 11 in fig 3.5.

Palazzani

INDUSTRIE



Information

An additional emergency button is fixed to the basket support.

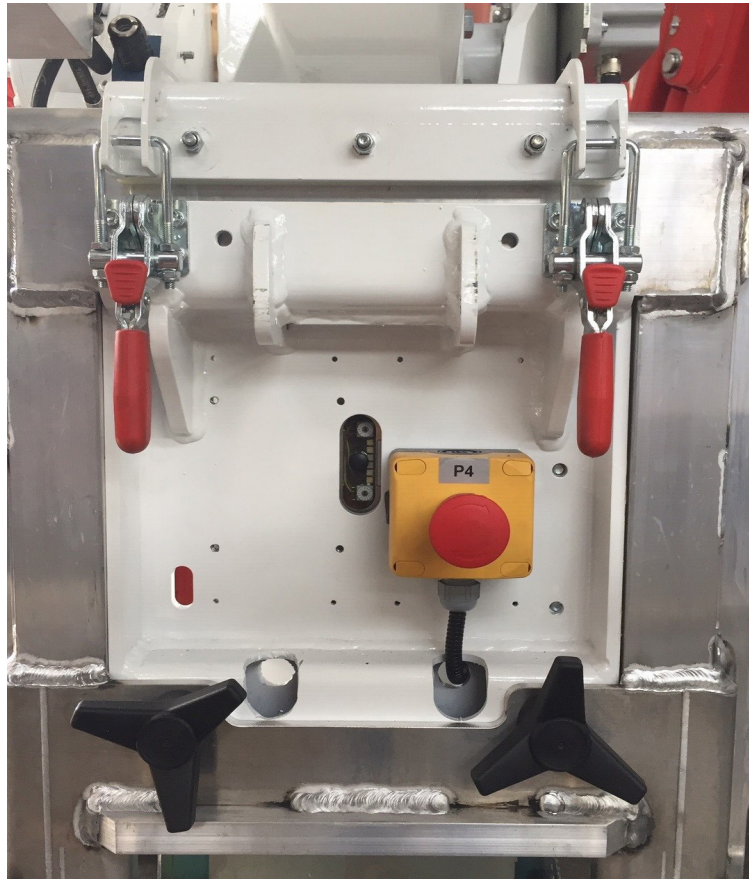

fig 3.5b

Palazzani

INDUSTRIE

3.4. PLATFORM STARTING PROCEDURE

Especially after a period of inactivity, before starting the engine it is recommended to check all the safety devices and controls.

Some of these controls can be fulfilled with the machine off, other controls after the stabilisers positioning. For the first ones:

- 1) Check the fuel level;
- 2) Check the hydraulic oil level;
- 3) Check the electrolyte level and batteries charge;
- 4) Check the track condition;
- 5) Check the stop buttons on the two control panels and on the main control panel;
- 6) Check the booms extension chains integrity and tension (the chains must remain tense to the touch and not loosen during boom extension and retraction).



WARNING:

Don't start the platform in case of any irregularity

3.4.1. TURRET TRAFFIC LIGHT MANAGEMENT

Fixed green:

Arm in rest position with the possibility of movement of the stabilizers.

Fixed yellow:

Movement blocked for anti-collision.

Red:

Always off.

Fixed buzzer:

Movement blocked due to collision avoidance, flat electric machine battery or excessive carriage angle during translation.

Slow intermittent buzzer:

Movement in progress (can be deactivated).

Fast intermittent buzzer:

Machine in translation (can be deactivated).

Palazzani

INDUSTRIE

3.5. USE WITH DIESEL ENGINE

The machine has two power sources one is independent generated by the diesel engine. This is used for the machine downloading from the truck and for the long transfers towards the working sites.

It can be used also for aerial work if the noise and gas emissions are not dangerous for the working site.

The diesel engine offers the advantage of faster movements of tracks and boom and energy saving.

To start the activity with this power source, proceed as following:

- Turn on the engine from the main panel (part 1 Fig. 3.1) in 1 position (oil and tension lamps switches on).
- Turn the key to start the engine.
- Leave the engine running some minutes (at least 5 minutes in winter temperatures).
- If it turns off after few minutes, wait at least 20 seconds before restarting it, because the protection of its switch prevent from near restarting.
- The engine is adjusted at a constant speed for aerial working, while during the transfer the tracks increases the rpm automatically if the speed selector switch on the control panel is on "rabbit".
- To stop it, push the red "STOP" button situated on one of the control panel or reset the key on the general panel; remember to unlock the "STOP" button, slightly rotating it otherwise the engine don't turn on from any other maneuvering site.
- The engine can be started also by the ground controls panel through switch 10 of fig. 3.4.

Palazzani

INDUSTRIE



WARNING

Exhaust pipe is not protected and burns also on the upper part of the diesel engine. During work with diesel engine in enclosed spaces, exhaust gas must be removed by means of an appropriate hose of a suitable material.



FIRE AND EXPLOSION RISKS

- Fuel of the engine can cause fires and explosions.
- Never fill up the fuel tank when the engine is running.
- Never smoke while refueling.
- Take all necessary safety measures during welding work or when you are near an open flame.
- Clean the machine from oily substances and non-fireproof debris or residues with non-flammable solvent.
- Batteries can also explode in the presence of sparks or open flames: ventilate the area and above all do not charge the battery in these conditions.
- The exhaust gases may contain sparks therefore the work area must be ventilated if there is the presence of flammable vapors, gases or liquids.
- Any leaks of hydraulic oil or fuel must be eliminated during scheduled maintenance.

Palazzani

INDUSTRIE

3.5.1. FUNCTIONS POWER AREA

To view the pagr proceed as described:

- Push the index / page change button (fig.3.2)

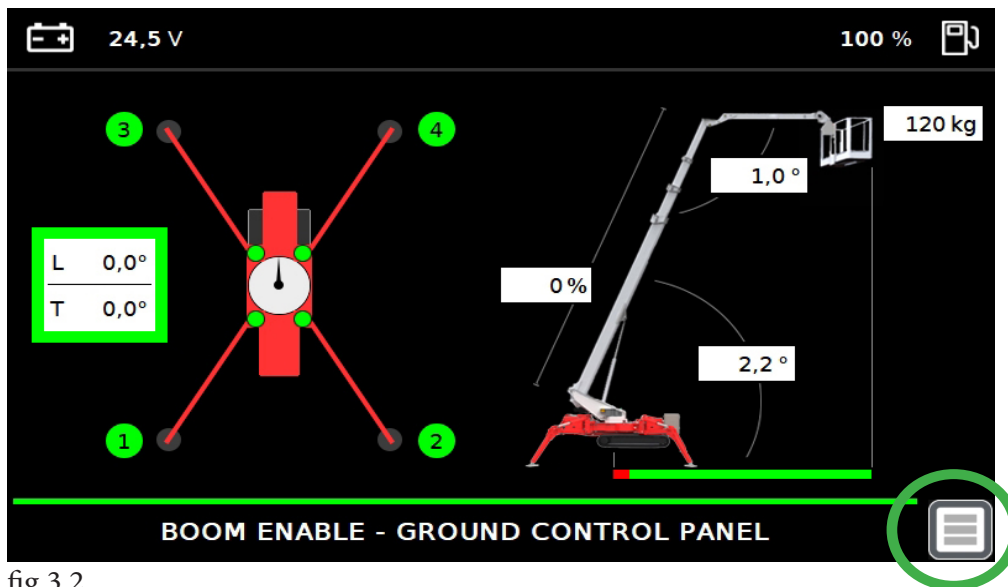
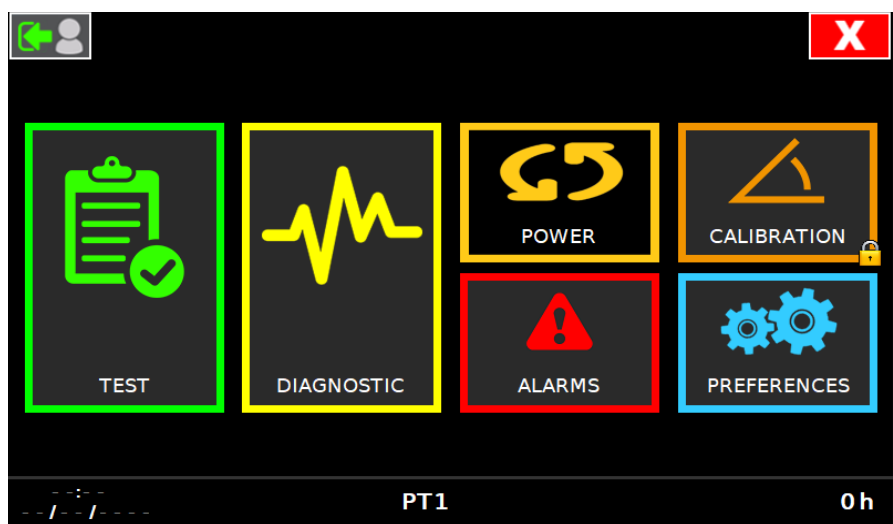

fig 3.2

- Push power page.



Palazzani

INDUSTRIE

In the diesel engine picture (fig. 3.3) it is possible to view other engine parameters and commands.

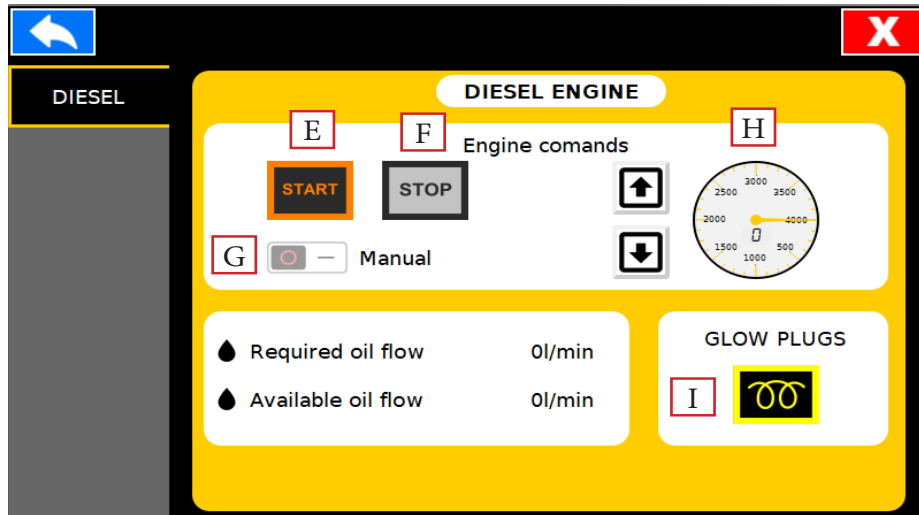

fig 3.3

E: Start diesel engine

F: Stop diesel engine

G: Automatic activation rpm diesel engine (only for emergency operations)

H: Rpm

I: Glow plugs

Palazzani

INDUSTRIE

3.6. PLATFORM WORKING WITH ELECTRIC MOTORS

This energy source use is recommended when the machine works indoor or where the exhaust gas or noise are forbidden and when the energy saving is important.

Where possible, it is recommended to branch always the platform to an electric source, in fact, el.motors can be used alternatively to diesel engine, for small aerial movements and, eventually, for recovery in emergency (i.e. diesel breakdown).

1. Differential switch + automatic for the cage socket
2. Differential switch + automatic for electric motor
3. Electric socket



fig 3.6a

Palazzani

INDUSTRIE

To work with this source of energy, follow these instructions:

- Turn the key (part 1 Fig. 3.1)
- Connect the plug of Fig. 3.6a to the net.
- Acting on any lever of the control panel, the electric motor starts automatically and all movements are possible.
- If the machine is not used for some seconds, the motor automatically stops. In alternative it can be switched off with “STOP” button or turning the key of the main panel on OFF.
- To restart it, unlock the stop button and move any joystick for a while.

NOTE:

For the efficient functioning of magnetothermic differentials switch (life-savers) on the machine, the electricity plug must be **safely** connected to the ground and be on a normal box; do not use flying cables sometimes existing on the working sites.

For greater efficiency of the differential switch, connect the machine chassis to the ground by means of a suitable screed in the ground by means of the screw shown in Fig. 2.5 chap.2.

When moving the equipment on the ground, be very careful not to crush the power cable with the wheels or tracks and to remain within the limit of the length of the cable itself. Furthermore, the power cable must not be longer than 15m and the section must be suitable for the load.

Palazzani

INDUSTRIE

3.7. PLATFORM SELFPROPELLING

To travel follow these instructions:

- Turn on the engine from the main panel (Part 1 Fig. 3.1)
- Turn the key of the control selections (Part 2 Fig. 3.1) on turntable symbol (central position).
- Activate the radio connection between transmitter and receiver (note on fig.3.4).
- Use the left and right joystick (Part 1 and 6 Fig. 3.4) to control the tracks.
- It is possible to rotate the machine on itself, actioning the two above mentioned levers in opposite direction, one forward and the other backward.
- Transfer always with tracks in enlarged position. Use the narrow position only to pass through corridors or narrow spaces and flat grounds.

It is possible to intervene on the transfer speed of the equipment in two different ways:

- 1) Increasing the rpm through the selector 14 Fig. 3.4
- 2) Actioning the selector 13 Fig. 3.4: in central position the speed is high, while on the left side the track motors displacement is reduced. Keep the selector 13 of Fig. 3.4 on the left side to make the steering easier.



WARNING

It is forbidden to travel with people or loads in the basket.



WARNING

“Rabbit” option corresponds to the max speed and it’s for long transfer on flat grounds and free from obstacles.
 “Snail” option corresponds to the min speed, which can be always switched to the fast speed, and it’s for transfer on slopes, indoor or on paths with obstacles (i.e. inside a workshop or a museum, etc).



IMPORTANT

Always face both the ascent and the descent with the arm facing uphill and slow down when passing the bump to avoid sudden oscillations of the extremity of the arm.



IMPORTANT

During the traveling it is mandatory to keep the rotation stop pin inserted in Fig. 3.12.



IMPORTANT

During transfer in an area opened to traffic, it is necessary to install a “working site” with skittles or berriers, to avoid collisions when the machine is not equipped with signaling devices.

Palazzani

INDUSTRIE

	<p>Information</p> <p>Often it is necessary to get the authorization from the local Authorities to build up the working site</p>
--	---

The stretch to be covered on an area open to the public must in any case be short, performed at favorable times, and if necessary, with the Police approval.

	<p>Information</p> <p>Here are some tips for travelling.</p>
--	---

Straight travelling:

To travel straight, move the tracks with the same speed and the same direction.

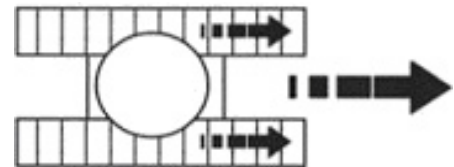

Wide radius steering:

To make a broad steering, move both tracks in the same directions, but with different speeds.

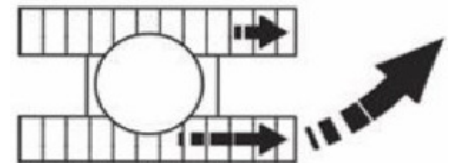

Steering on the spot:

To steer on the spot, move the tracks in opposite directions with the same speed.

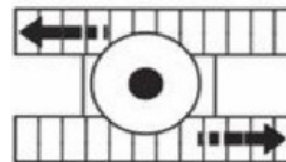

Steering with one track:

Palazzani Industrie does not recommended this maneuver, as it produces an accentuated wear of the sliding parts of the tracks with possible overriding of the chain on the toothed wheel.

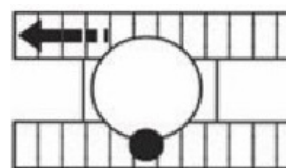

	<p>WARNING</p> <p>The pins control bypass function is allowed only for the stabilizers lowering, without touching the ground. THE MACHINE LEVELING WITHOUT PINS IS NOT ALLOWED</p>
--	--

	<p>IMPORTANT</p> <p>In steering phase, use the selector 13 Fig. 3.14 to facilitate the maneuver.</p>
--	---

Palazzani

INDUSTRIE



INFORMATION

Keep activated for 5 seconds the switch 12 of fig. 3.4 to activate the assisted translation. When this function is activated, the operator can control both tracks using only the joystick of the right track (this function is very helpful when the machine has to transfer in delicate situations like stairs, slopes, etc...). To deactivate this function, pull the switch 12 of fig. 3.4 for 5 seconds.

3.8. TRACKS ENLARGING (in models where this function is available)

Transfer must be **always** be fulfilled with enlarged tracks, to get the sufficient stability also on uneven grounds or slopes.

It is possible, however, in some particular situations such as doors or narrow corridors passages, etc, to transfer with narrow tracks; but in these cases the ground must be solid, flat and uniform.

To enlarge or tighten the tracks, it is necessary to lift the tracks from the ground by means of the stabilizers (see paragraph 3.13). Once the tracks are up, select the control key on stabilizers (Part 2 Fig. 3.1), act on switch pos. 13 Fig. 3.1 and at the same time act on the accelerator lever Part 6 Fig 3.4 to enlarge the tracks. To narrow them act on the switch in the opposite direction.

3.9. STEERING

Steering is made by one track slide in respect to the other and it is necessary, therefore, to reduce the speed of the right track or left track by using the two transfer levers.

As already mentioned, the steering space can be reduced and the machine can rotate on itself actioning levers 1 and 6 Fig 3.4 one forward and the other one backward. This operation, however, must be done only if necessary and on flat and regular floor (asphalt, pavement, etc)

3.10. AUTOMATIC BRAKE

Braking is automatically guaranteed by negative mechanical brakes with hydraulic release; the release of the translation control causes the immediate intervention of said brake also assisted by the overcenter and anti-cavitation valves mounted on the transfer motors.

Uphill and especially downhill, switch selector 14 in fig. 3.4 on “Snail” for even more decisive braking and parking.

Palazzani

INDUSTRIE

3.11. SPECIAL FUNCTION BUTTON FN

On the main panel there is a button named FN (Part 9 Fig. 3.1), with this switch you can:

- 1) lifting and lowering the boom when the machine is travelling on tracks
- 2) move the stabilizers without pins

Function 1

In case of a particularly important slope or truck loading ramps, the boom can be lifted of the needed angle to avoid the cage touching the ground, even without giving pressure to the stabilizers, with the extensions boom totally retracted.

Follow these instructions:

- Turn on the diesel engine.
- Check the key selector (Part. 2 Fig. 3.1) it must to be in the centered position.
- Press the button FN (Part. 9 fig. 3.1), the button starts to blink followed by an intermittent sound. The display will show “parking movements” as indicated in Fig 3.6b.

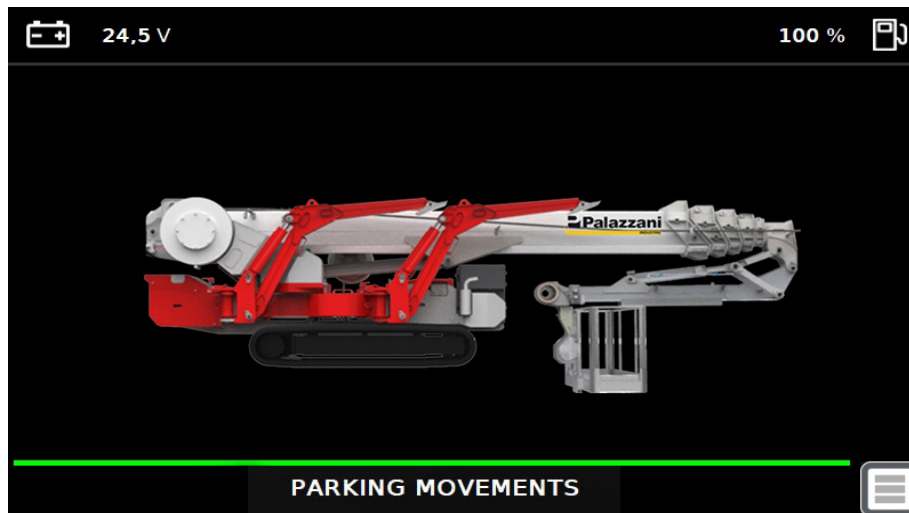

fig 3.6b

- From control panel at the ground it is possible to performe these maneuvers:
 - Lifting/lowering the boom
 - Rotating the turret
 - Closing the jib
 - Rotating the cage
- At completed operation push the FN button on the control panel (part 9 Fig 3.1) to re-activate the travelling mode.

Palazzani

INDUSTRIE



Information

The system can interrupt the boom maneuvers automatically, in this case appear on the display it will appear “anticollision active” (Fig 3.6) followed by the orange light (in the turret Fig 3.7) and by a fixed sound. In the “active booms anticollision” phase to move the boom it is necessary to action at the same time also the button of automatic closing on the radiocontrol (Fig. 3.7a).

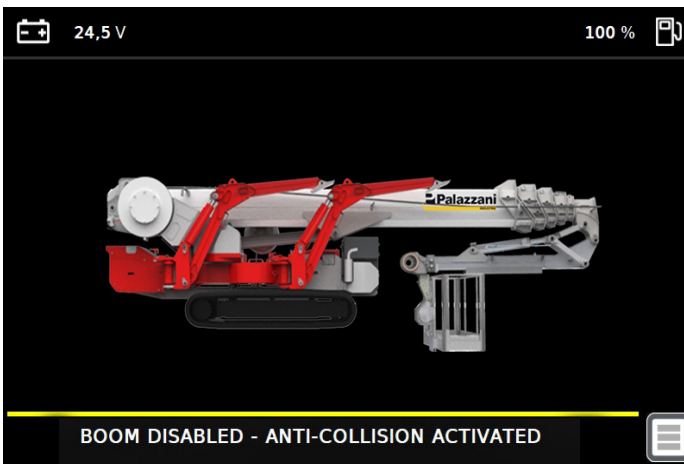

Fig 3.6

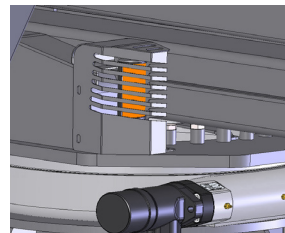

Fig 3.7

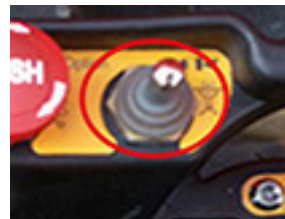

Fig. 3.7a



DANGER

Transfer with the lifted boom only on flat floor and with slow speed. Do not transfer on slopes even if slight slope.

Function 2

There are situations in which it may be necessary to lower the stabilizers, on some models, also to reduce the maximum height, or when dealing with very steep terrain. In the latter case, it may be useful to lower the stabilizers up to a few centimeters from the ground, because due to the forces of inertia, if the machine loses stability, the stabilizers rest on the ground avoiding its overturning.

Normally the stabilizers movement is allowed only when the articulations pins are inserted, or when this selector is activated.

To move the stabilizers without pins, follow these instructions:

- Turn on the diesel engine.
- Move the key selector (Part 2 Fig. 3.1) to the “stabilizers” position (on the right)
- Check the green light on the turntable, this means that the boom is in centered position, lowered and retracted.
- Press the FN button on the panel (Part 9 Fig. 3.1) and at the same time move the stabilizers like a normal situation (using the control proportional lever and the stabilizers joysticks which must be moved).

Palazzani

INDUSTRIE

3.12. LEVELING THE MACHINE

Depending on the different needs, the stabilizers can be set-up on the ground with different positions, rotating their supports which connect them to the chassis. Once the desired position is decided, the pins must be inserted in the appropriate holes and the locking pin of the above mentioned supports to the chassis to maneuver the boom (Fig. 3.8).

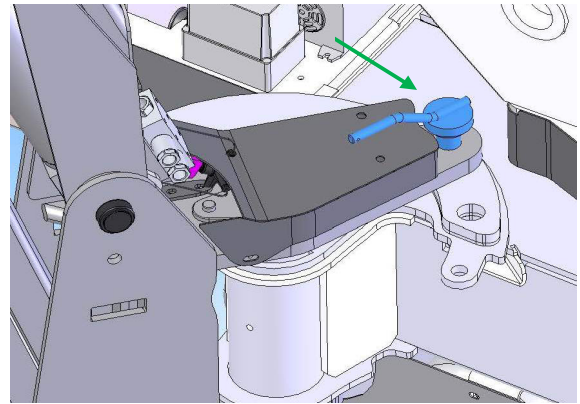

fig 3.8



IMPORTANT

It's important to consider the relationship between the working area and the position of the stabilizers in order to stabilize the platform in the best way.



DANGER

In case of floors and basements, check if the slab capacity supports the pressure on the stabilizer. This data is indicated in the sticker on every stabilizer.

If possible, the best stabilizers set-up is always the larger one, which allows a more homogeneous working area over 360°.

Now it is possible to position the stabilisers on the ground acting as following:

- Select the control key part. 2 of fig. 3.1 on the “stabilizers” symbol (right position)
- Check the green lamp on the turntable, it must be switched on, to confirm that the boom is in central, low and retracted position (Fig. 3.10).
- Be sure that all stabilizers pins are correctly inserted (Fig. 3.8).
- Set the selector n°10 of fig. 3.1 on the needed set-up mode.
- If the stabilization is set on automatic, just operate the lever part. 1 of fig. 3.4 in down direction stabilizers. The stabilizers will begin to descend until the machine is completely leveled. By holding down the green button (fig 3.10a) and activating the radio control lever 1 in fig 3.4, the machine will automatically begin to rise up to the maximum permitted height without leveling.



fig 3.10a

Palazzani

INDUSTRIE



Information

At any time, by releasing the green button fig 3.10a and keeping lever 1 pulled of fig 3.4, the machine will automatically begin to level itself in the position it is in.



DANGER

It's forbidden and very dangerous to use the platforms with the bubble over 2° (Fig. 3.9)

Use wooden plates to make the ground more solid, which must be wide enough to avoid dumping and high no more than 15 cm. It can be necessary to position the stabilisers on different height levels (i.e. on stairs, side-walks, slopes, etc.) and this is easy because the stabilisers can be lowered independently.



Fig 3.9



OVERTURNING DANGER

It's forbidden to stabilize the machine with one or more stabilizers on an obstacle higher than 20 cm tall (Fig. 3.9a).

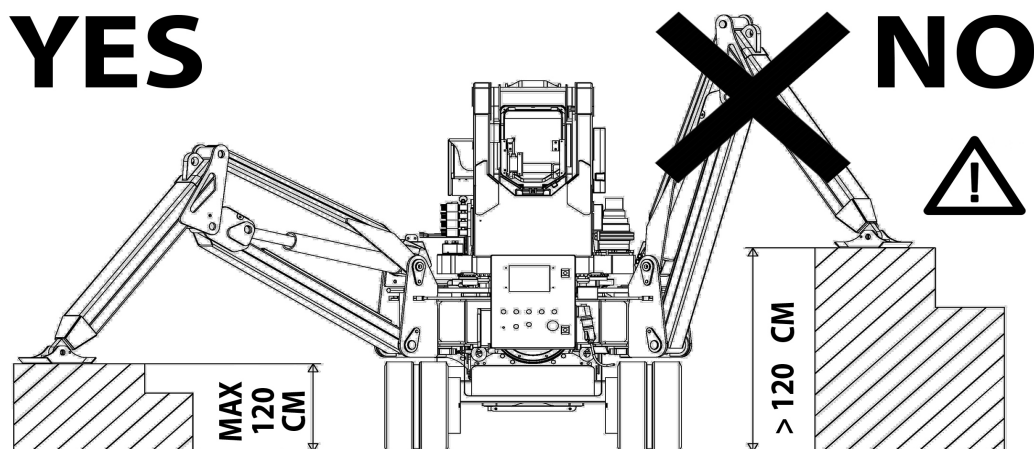

Fig. 3.9a

Palazzani

INDUSTRIE

! **WARNING**
Always check the chassis flatness, even if the placement was performed with the automatic function.

! **WARNING**
Always check that the plates are solidly positioned on the ground (it is dangerous to put them on gutters, near scarps, on soft or watery soil, etc.)

To retract the stabilizers, check that the green light on the turntable (Fig. 3.10) is lighted on. Turn the key 2 of fig. 3.1 on stabilizer symbol, use the accelerator lever part. 6 of fig. 3.4 and the lever from 1 to 4 in the upward direction of the stabilizers until the stabilizers are fully retracted.

This operation can be done in automatic mode using the selector on the main panel (11 fig. 3.1) or the control panel at ground if the selector 10 of fig. 3.1 is on "AUT".

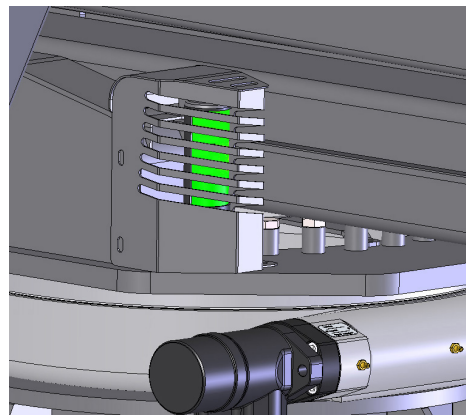

Fig 3.10

! **DANGER**
The max slope between the two support planes of the stabilizers plates can not exceed 5°, independently from the escarpement, to avoid the machine sliding due to the limited friction resistance (Fig. 3.11).

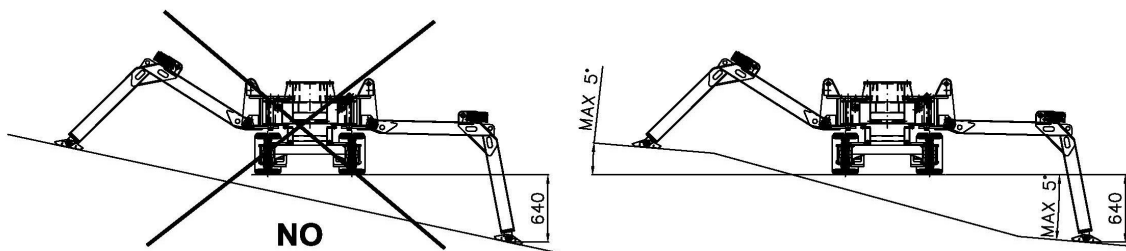

Fig 3.11

Palazzani

INDUSTRIE

3.13. AERIAL WORK

Access to the platform

	<p>WARNING</p> <p>Do not start an aerial work without an assistant from the ground, whose presence is compulsory to recover the cage to the ground in case of control system defeat.</p>
--	---

	<p>DANGER</p> <p>Operators must not exit and access from the cage from high position.</p>
--	--

	<p>DANGER</p> <p>Stay on the cage only for lifting and working in high position. During the transfer, operators must not stay on board.</p>
--	--

Protections don't grant all risks from a possible overturn. If the light and the overloading acoustic alarm activates, quickly download the exceeding load.

If the cage has to lift beyond an obstacle (river, difficult ground..) it is advisable to try before with a similar weight (ie. 2 persons) and check if the boom reaches the wished position without stopping.

After positioning the stabilisers on the ground and leveling the chassis, the machine is ready for aerial work; the controls panel at the cage must be activated by means of the proper selector (part 2 Fig. 3.1 left position).

	<p>IMPORTANT</p> <p>Before performing any turntable movement, take the rotation locking pin off Fig. 3.12.</p>
--	---

From the control panel at the cage, the boom movements are allowed. In fig. 3.5 all maneuvers are indicated, with the relative joysticks. It is, however, possible to activate the control of the aerial movement also from a different position, with the proper key (in case of maintenance, settings, training course, etc.).

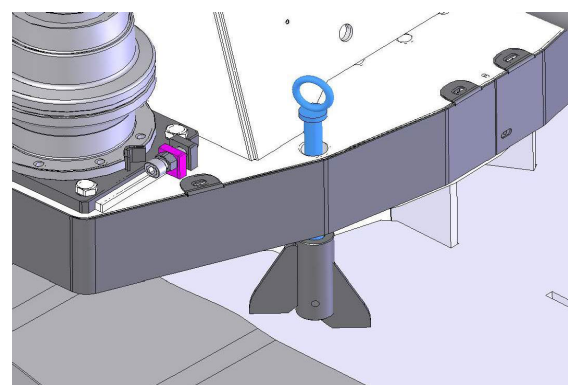

fig 3.12

Palazzani

INDUSTRIE



DANGER

Fix the safety belt to the anchor rings (with a rope not longer than 1 meter) before performing any movement (Fig. 3.13).

Act on the chosen control panel levers, to perform the movements, avoiding sudden maneuvers.

First lift the first boom around 45° and then open the jib to get away from the boom; then you can proceed with turntable rotation and telescopic extensions.

Do not make abrupt maneuvers or sudden inversions in movements to not counterblow the cage.

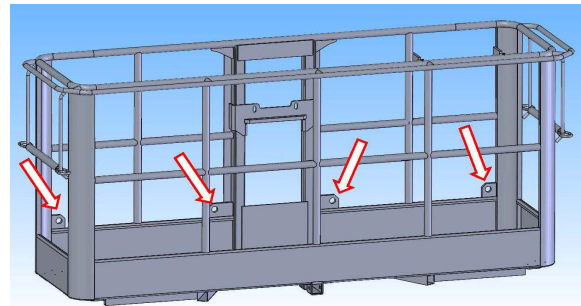

fig 3.13

The more the telescopic are extended the lower must be the transfer.

To go back to rest position, retract the extension completely, close the jib, straighten the cage eventually rotated, put the chassis on axle rotating the turntable and lower with the first boom until the green light turns on (Fig. 3.10).

The above mentioned green light activates only when the booms are: completely retracted, on the longitudinal axle in respect to the chassis towards the diesel engine.

From this moment it is possible to lift the stabilisers selecting the stabilisers symbol with the key Fig. 3.1 part 2 and proceeding as described in the dedicated paragraph.

Palazzani

INDUSTRIE

3.14. WORKING AREA AUTOMATIC LIMITING DEVICE

The platform is equipped with an intelligent automatic limiting device, that controls the outreach depending on some factors:

- Stabilizers position
- Weight in the cage
- Boom position in respect to the stabilizers
- Boom angle
- boom extension.

In the machine management software there are tables in which for each angle of the arm there is a very precise outreach when the value of the outreach reaches the maximum value shown in the table, the red light turns on on the basket control panel (Fig. 3.5 pos. 9) and on the ground control (Fig. 3.4 pos. 8).

The only maneuvers always forbidden from the maximum outreach situation are: boom lowering and extension; sometimes the turntable rotation is forbidden also, but it depends from the boom and stabilizers position.

Act on the remaining maneuvers to establish the complete functions, retract the extension and lift the boom until the red lights on the stabiliser and on the control panel are off.



DANGER

This limiting device is vital for the machine and operators; do not try to by-pass or deactivate it or modify its setting to avoid dumping or breaking risks with disastrous consequences to people and things.

The area set by the manufacturer is the max reachable in safety conditions; trying to increase it with interventions on the system or safety devices is very dangerous for operators.



WARNING

Do not load material on the cage when the boom is already extended; if it is necessary to do that (i.e. disassembling or substitutions) check if the red light is on on the maneuver panel and load small weight every time without exceeding the nominal load.



DANGER

When the red light is on do not load further weight and act the telescopic retraction for first until its switching off.

Palazzani

INDUSTRIE

3.15. LOAD LIMITING DEVICE

The machine is equipped not only with an outreach limiter but also with a load limiter in the basket, this device prevents the nominal capacity from being exceeded and if this happened, it would cause the stop of all maneuvers and the activation of an acoustic and light alarm in the basket.

To restore the movements, the excess load mistakenly loaded must be removed.

If this is not possible, if for example the basket is stuck between tree branches or under an overhang, it is necessary to restore the movements by operating with an emergency maneuver as described in chapter 4.

3.16. CAGE ROTATION

The basket has a rotation movement on the vertical axis. This movement is activated by a joystick on the control panel (Fig. 3.4 part 4) or by a selector on the cage control panel (Fig. 3.5 part 5). For obtaining a complete rotation, keep the jib horizontal to avoid contacts between the cage and the boom; remember to return to the orthogonal position to the boom before lowering to rest.

3.17. AUTOMATIC CAGE ORIENTATION

The cage can rotate on the horizontal axis to grant a constant leveling with ideal horizontal plane. This movement is automatic and obtained by an electronic pendulum with a proportional electrovalve which sends the oil from the main circuit to the cage orientation hydraulic motor. The system is managed by a special electronic inclinometer.



INFORMATION

As already mentioned, the cage is assisted by an electronic device which activates during the boom movements.

To avoid the cage horizontality loss, if there's no a defeat, it is useful to act the lever smoothly during the jib maneuvers. If the cage exceeds 8° of inclination, all boom movements stop to give to the system the time to level the cage.



INFORMATION

In case the cage inclination exceeds the safety level, all machine movements stop and the emergency maneuvers described in chapt. 4 are possible.

Palazzani

INDUSTRIE

3.18. ELECTRIC CURRENT GENERATOR (OPTION)

The generator is actioned exclusively by the diesel engine, providing 230V AC mono-phase, for a real power of 1,5 CV, which is more than sufficient to use tools, small compressors and water pumps, both from the ground and from the cage.

It's possible to turn on the generator by the selector part 3 Fig. 3.5, when the diesel engine is running, the stabilizers are on the ground and the key movements selector is on the basket symbol.

It is good practice to check the functionality of the magneto-thermal differential weekly (life saving Fig. 3.6a); with the generator switched on, press the test button and check that no more current reaches the socket on the basket.

If there is a loss of current and the differential intervenes, have the electrical system checked by a competent person.

3.19. INTERCOM (OPTION)

Using the Intercom is possible to communicate between the people in the cage (Fig. 3.14) and the people on the ground (Fig. 3.15).

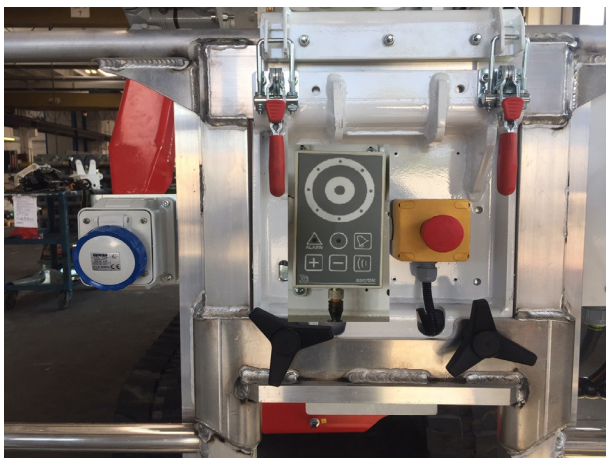

fig 3.14

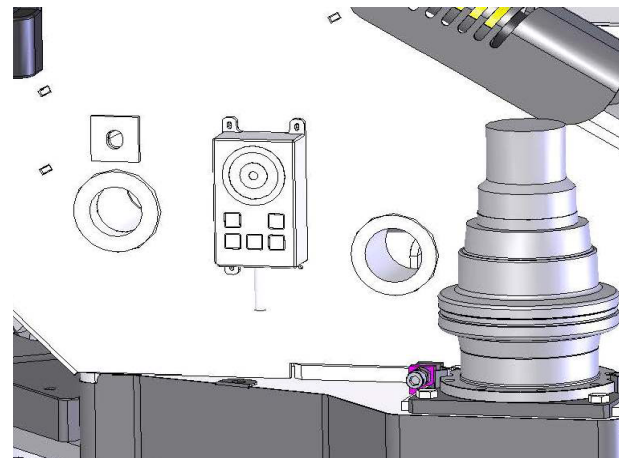

fig 3.15

SKYTALK is an industrial watertight interphonic which permits a perfect communication from two stations far from each other.

Its constructive quality makes it an object suitable to applications in extreme atmospheric environments.

Palazzani

INDUSTRIE

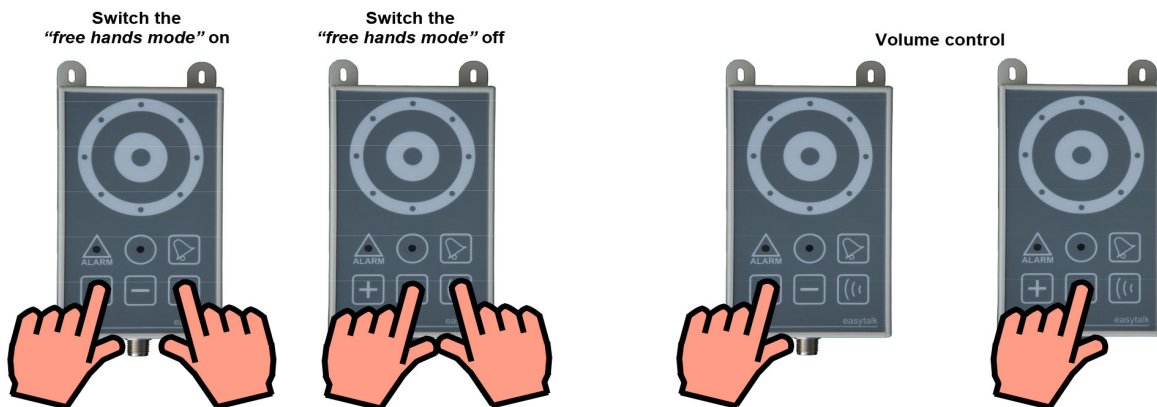
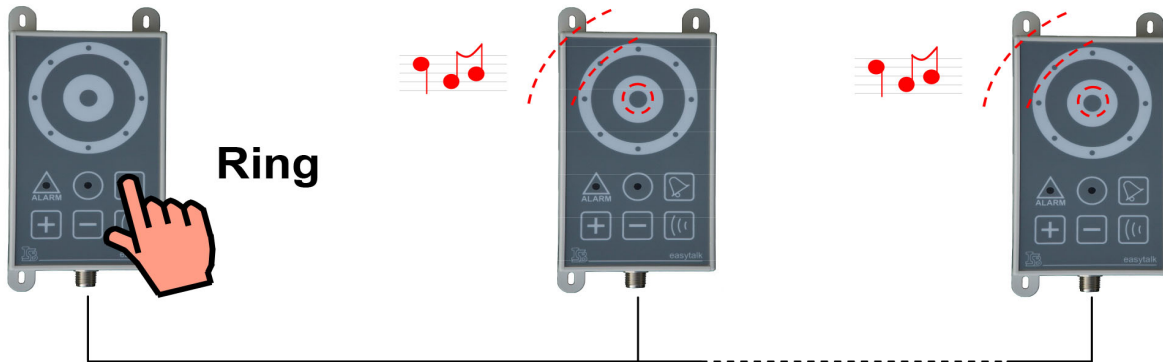

Flashing >>> power on
 Continuous >>> talk
 Alarm

If an alarm signal stops your conversation, push again to re-start your talking.

Palazzani

INDUSTRIE

3.20. MANEUVERS AND GROUND CONTROL PANEL

Before starting a new work or after a long stop period, it's better to proceed with some visual check to control the proper working of the equipment.

Follow these instructions:

- Check the display of the machine, it must show the current stabilizers position.
- Check the green lamp on the enabled control panel. Try to enable the other control panel and check again the lamps.
- Check the green lamp on the turntable, it must be on (Fig. 3.10).
- Lift the boom till this green lamp turns off. Lower the boom till the lamp switch on again. Now try to rotate the turntable till the lamp turns off.
- When that lamp is switched off, try to move the stabilizers (**it must not be possible**).
- Open the jib slightly and extend the boom until it stops when the red light on the control panel comes on (Fig. 3.4 pos.8).
- Now try to lift up the boom and after lower it (if the lamp is still switched on, this operation must not be possible).
- Verify the green lamp on the control panel: it must be turned on also when the red one is switches on.
- Try the buttons to turn on and off the engine.

3.21. MANEUVERS AND CAGE CONTROL PANEL

After checking the ground control panel, check the one on the basket follow these instructions:

- Try all the movements just described.
- Extend the telescopic till the red lamp on the control panel switches on (fig. 3.5 pos. 9). Now check the impossibility to make the descent and telescopic extensions maneuvers.
- Verify the cage rotation.
- Verify the emergency STOP: make a maneuver and push the stop button, the machine has to turns off.
- Connect external line on the plug and verify that el.motor runs and turns off if you turn on the diesel.
- Check the load limiting device: put a load higher than the capacity in the basket and verify that the red lamp and the acustic signal are blinking. In this situation every maneuver is inhibited.

Palazzani

INDUSTRIE

3.22. SPECIAL DIRECTIONS

Cold weather

In favourable climate conditions act with a special procedure, most of all in first starting of the engine:

- Start diesel engine and let it run almost 5'; in case the engine stops, wait almost 30 seconds before re-start it (there is an internal interlock to avoid multiple starts)
- After this time, accelerate it moving the selector on the "rabbit" symbol to enable the fast travelling.
- Operate the first movements gently in order to give time to the warm oil coming from the pump, to fill the cylinders.
- Leave the engine turning for 15 min even if the aerial work does not requires it.
- The first movements during the first drives can be not linear, but as soon as all the oil will reaches the proper temperature, all the movements will return regular.

Driving on a slope

In case of slope grounds, first select the slow speed "snail" and observe the following:

- Keep the basket towards the slope.
- To travel on a slope, proceed slowly to avoid the abrupt change of slope. In some cases is very useful to lower the stabilizers till some centimeters near the ground, in this way if the machine overturns the legs will touch the ground avoiding the overturning.
- Keep the boom as low as possible.
- Do not control the machine staying closed to the tracks, take the sufficient safety distance.

Lighting

For night working or in few lighted sites, use the electric socket on the cage to light a lamp.

Palazzani

INDUSTRIE

3.23. DISPLAY TOUCH SCREEN

On the main electrical box (part 3 Fig. 3.1) there is a touch screen display very useful during the operations with the machine.

The home page changes automatically according to the conditions of the platform: if it's in travelling mode the display shows the Fig. 3.16.

On the bottom, the display shows a message that informs the operator about the conditions of the machine and helps the operator with important tips.

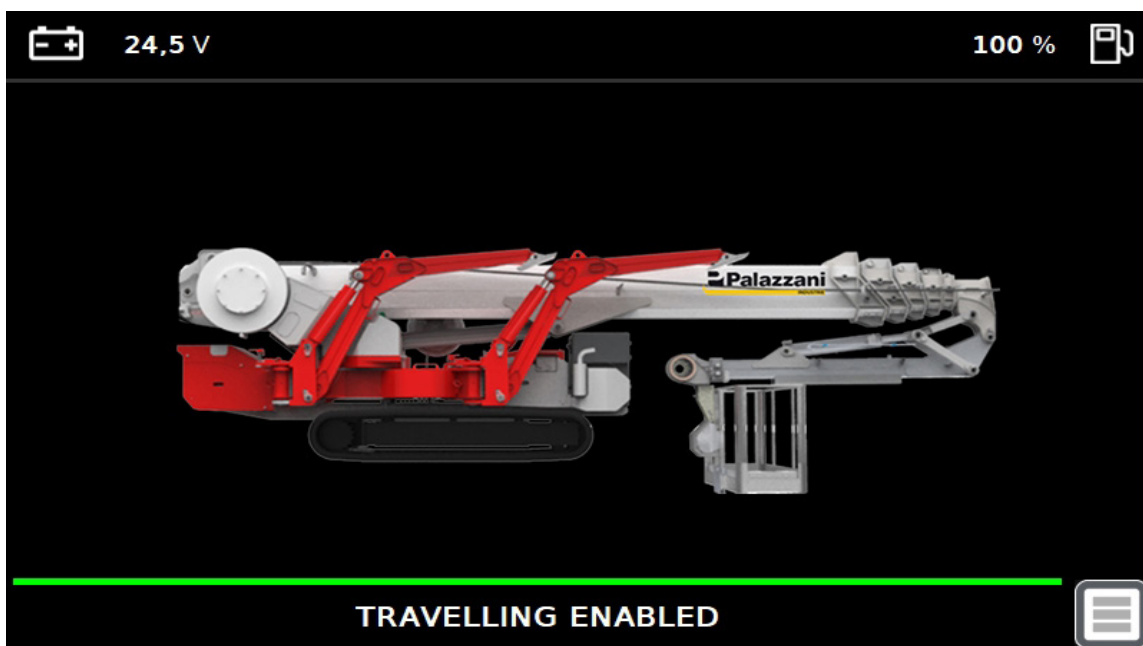

Fig 3.16

If the platform is working with the boom, the display shows the screen of Fig. 3.17.

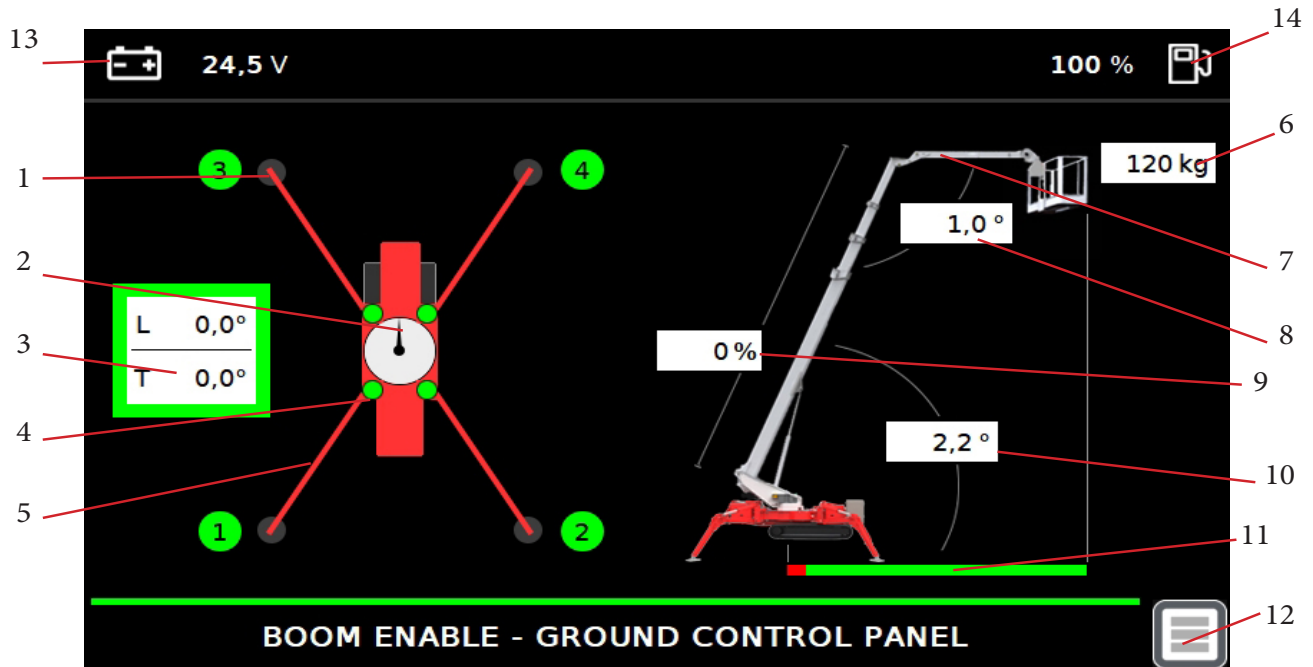

Fig 3.17

This page shows many informations, infact from this page you can understand:

- 1) If the stabilizers pressure on the ground is correct
- 2) The position of the boom on 360°
- 3) The chassis angle (the box turns green if the chassis leveling is good)
- 4) If the stabilizers pins are inserted
- 5) If the stabilizers configuration is large or narrow
- 6) The weight in the basket
- 7) The jib retracted
- 8) The jib angle
- 9) The boom extension in percentange
- 10) The boom angle
- 11) The residual outreach
- 12) Index, page change
- 13) Level battery indicator
- 14) Level fuel indicator

The botton in the lower right corner pos. 12 Fig. 3.17 opens the main index of the system (Fig. 3.18) where you will find six different areas:

- Test
- Diagnostic
- Power
- Alarms
- Preferences
- Calibrations

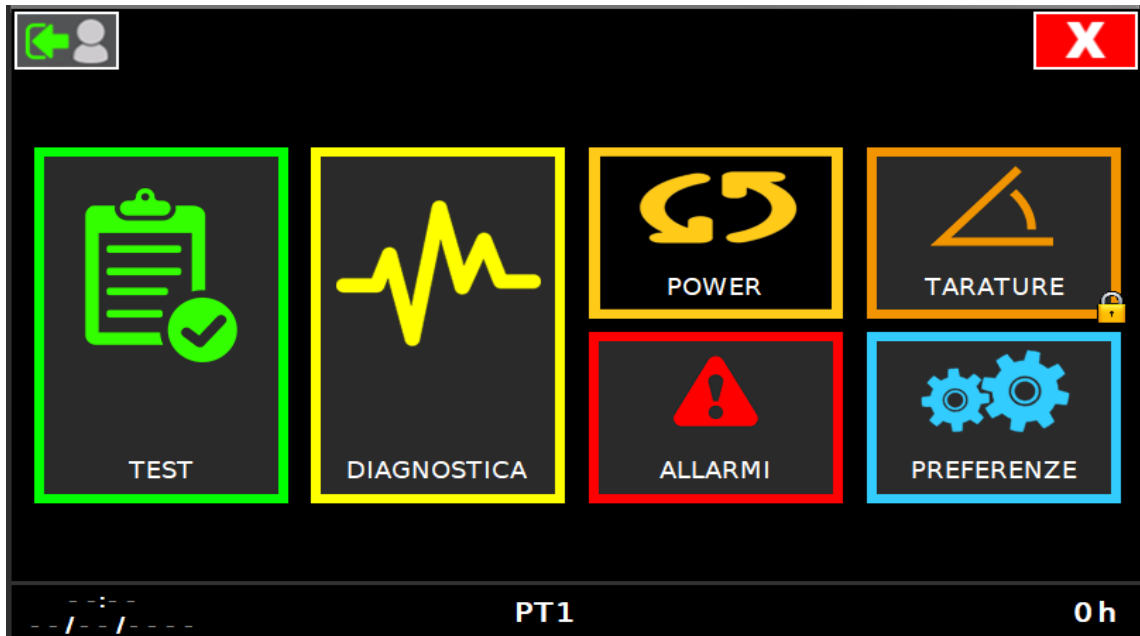

fig 3.18

TEST

From this index it is possible to test limit switches and sensors of the machine (like showed in the chapter 5).

DIAGNOSTIC

This index is very useful for the troubleshooting in case of failure of the machine.

POWER

From this page it is possible to consult the status, parameters and functions of the diesel engine.

ALARMS

From this page you can check all the alarms occurred on the machine in the last 60 days.

PREFERENCES

From this page you can change some basic settings like the language, the time, the hours, ecc....

CALIBRATIONS

From this page you can calibrate all the sensors of the machine (only with password).

On the lower right corner, are showed the working hours of the machine.



Fig 3.19

The screen of Fig. 3.19 is showed when there is a failure on the machine. In this case call a technician to solve the problem.

Palazzani

INDUSTRIE

4. EMERGENCY CONDITIONS

4.1. DEFINITION

Intervention under emergency conditions is the recovery of the personnel blocked on the cage in aerial position, for a sudden illness, or for a breakdown.

The reasons for a recovery can be of two kinds: illness of the people driving the cage or machine damage (due to a lack of the engine power, failure of the pumps, battery or flexible pipes damage, electric failures).

In this last case, the persons on the platform may have become unable to move but can use the emergency devices placed near them.

Any other emergency situation (fire, earthquake, etc.) is not considered, as the machine is not designed for fire-fighting and for rescue service.

Time for the recovery operations is not necessarily short.



Information

To perform some emergency maneuvers, may be necessary the help of more people.

4.2. EMERGENCY CONDITIONS

The platform is provided with safety devices protecting the personnel during the normal work and also allowing the recovery in case of a possible breakdown.

Main emergency devices are: dual power source, dual control panels, emergency stop buttons, intercom communication system, supplementary hand pump, direct control of electro-distributor valves.

1. Rules to follow during the emergency operations

Platform is provided with several devices for aerial cage recovery. Therefore, it is recommended to follow these directions, avoiding operators descent by cables, along the boom, etc. **IT'S VERY DANGEROUS !!!**



Danger

In case the operator on the aerial cage is seized by a sudden illness, before touching the platform, be sure that the boom or the cage are not in contact with live electric lines.

DON'T TOUCH THE PLATFORM, ALSO FOR PERSONS AT GROUND THERE IS A SERIOUS ELECTROCUTION HAZARD

Palazzani

INDUSTRIE



Important

When the emergency recovery ends, call the responsible in order to check the machine by a qualified technician, and give him more information as possible about the machine condition when the failure occurred.

2. Hydraulic power

In case of a breakdown of the diesel engine, it is recommended to connect the electric motor to a feeding line, so operators have an alternative power source at their disposal also in emergency; on the contrary, in absence of electric energy, the power source can be replaced with the starting of the diesel engine.

In both cases the work can continue and all safety devices are regularly working.

3. Controls

In the event of a fault in the basket controls or a sudden illness of the operator, it is possible to switch the controls on the ground and operate both for recovery and for the continuation of work because also in this case all the safety devices are active.

4. Emergency stop

Emergency red push button is mounted on all control stations and, when pressed, it allows to stop the energy source activated at that moment.

Push-button is of self-retaining type and permanently cuts re-starting system from any control station if it has not been re-set by rotation.



Information

If you do not succeed in starting the diesel or the electric engine, check whether one of these “stop” buttons has been left stuck down or not.

5. Upper control exclusion

In case of a breakage of hydraulic hoses along the boom and feeding electro-distributor valves mounted on the jib, the recover of the people on the basket would be impossible. In this situation, you must turn off the engine by an emergency stop button and then intervene to close the “Upper controls exclusion” lever valve.

With the close tap, the maneuvers: basket rotation, automatic leveling, jib opening and closing will be impossible. For all the other movements, follow the instructions in this chapter.

Palazzani

INDUSTRIE

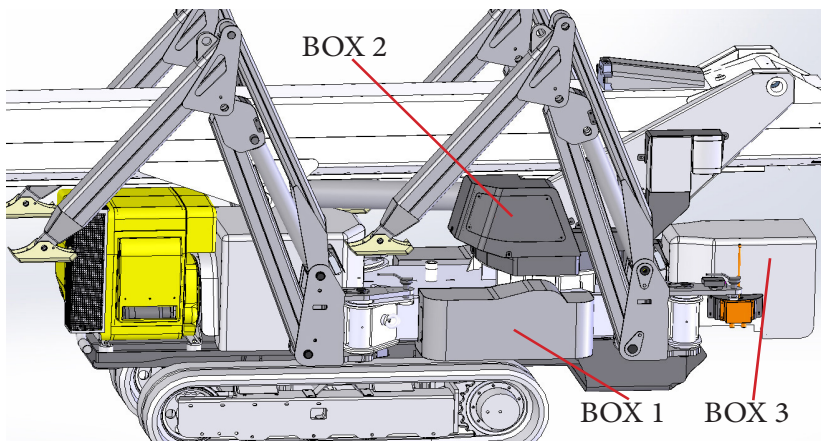

Fig.4.1

Pictures 4.1 and 4.1a are showed all the boxes where are located the emergency valves.

Every electro-valve is named with the word EV and a number.

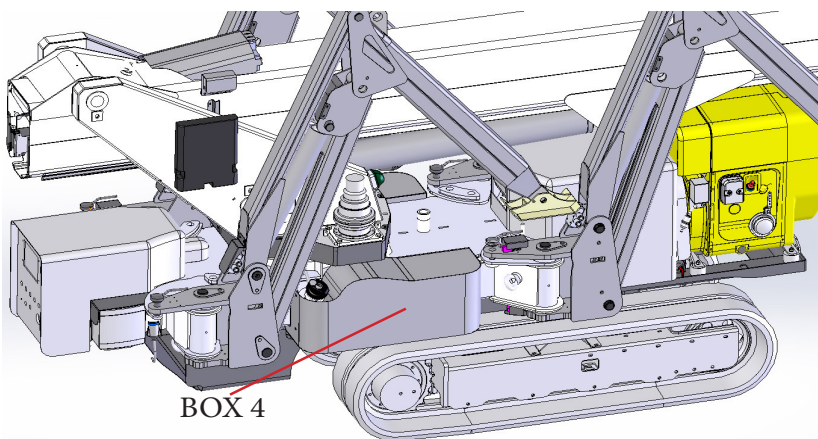

Fig.4.1a

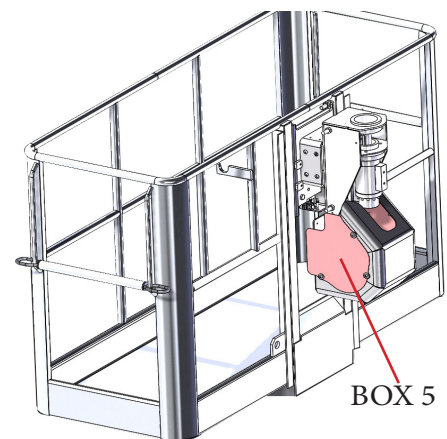

Fig. 4.1b

Box 1: EV9, EV03, upper movement exclusion.

Box 2: hydraulic distributor for the boom, EV23, EV26, EV10.

Box 3: hydraulic distributor for tracks and proportional oil for stabilizers.

Box 4: EV6, EV11, EV12, EV13, EV14.

Box 5: EV15, EV16, EV17.

4.2.1. SAFETY POSITION OF THE CURSOR DURING THE NORMAL USE OF THE PLATFORM (AFTER THE EMERGENCY RECOVERY OF THE PLATFORM).

- EV9: UNSCREWED
- EV3: SCREWED
- EV23: NOT PRESSED
- EV26A/B: NOT PRESSED
- EV10: NOT PRESSED
- EV6: UNSCREW

Palazzani

INDUSTRIE

6. DC pump for emergency

In case of failure, it is possible to recover the boom using the DC pump like a source of energy (it is connected directly to the battery).

To start the electric engine, press the optional button.

DC pump can work for some minutes for every quarter of hour, so it is important to take some breaks during the recovery, so as not to overheat the electric motor.



The electric pump should only be used for emergency recovery operations.

Palazzani

INDUSTRIE

4.3. PERSONS RECOVERY FROM THE CAGE IN EMERGENCY

Machine working

It is possible to recovery personnel on the aerial cage turning the key to “turret” symbol (Fig. 3.1 part 2); in this case all the safety devices are activated and you can also continue working.

Anomaly to the electric plant

In this case engines and pumps are working regularly, but is not possible to make every movement of the machine for a failure in the electrical plant.



DANGER, WARNING!!!

If the machine has almost one stabilizer in the narrow configuration, THE FIRST MANEUVER TO OPERATE IS TO MOVE THE BASKET ON THE LOGITUDINAL AXE OF THE MACHINE (Fig. 4.2a). Follow the procedure of the turntable rotation showed in the next step.

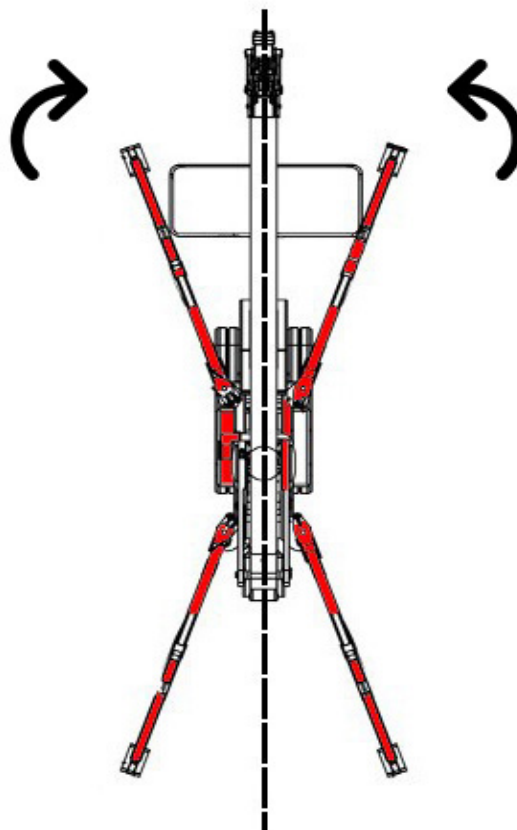

Fig 4.2a



WARNING

During the emergency recovery, the basket leveling system is disabled.

Palazzani

INDUSTRIE

Following the instructions to recover the basket:

- Remove the protections of the boxes described above.
- To insert EV09 simply rotate the safety cursor until it is completed (fig. 4.3 and 4.3a)



WARNING

If the led on the connector of EV3 is switched on, the boom movements are inhibited; the operator must disconnect the connector from the spool of the electrovalve EV03.



Fig 4.3



fig 4.3a

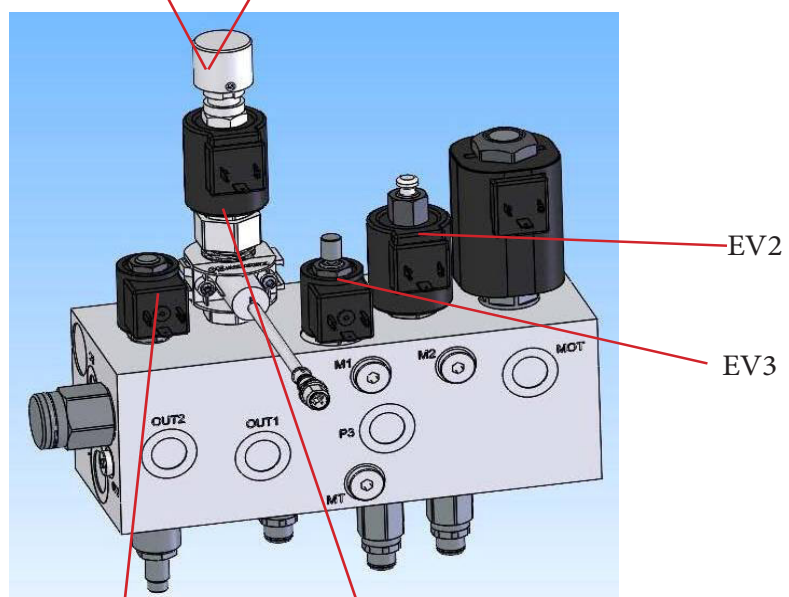

fig 4.2

EV8

EV9

EV2

EV3

Palazzani

INDUSTRIE



WARNING

Every time EV09 is switched on, the message “COMMAND ERROR EV09” appears on the display (fig. 4.3b).

To remove this error and to use the platform again, simply switch the machine off and on again.



fig 4.3b

Palazzani

INDUSTRIE

- **Retraction of telescopic extensions**

With the engine running, open box 2 containing the movement levers and operate the telescopic arm retraction lever VD4 (Fig. 4.4) until the extensions are completely retracted. Refer to the pictograms on the distributor box to activate the correct movement of the machine.

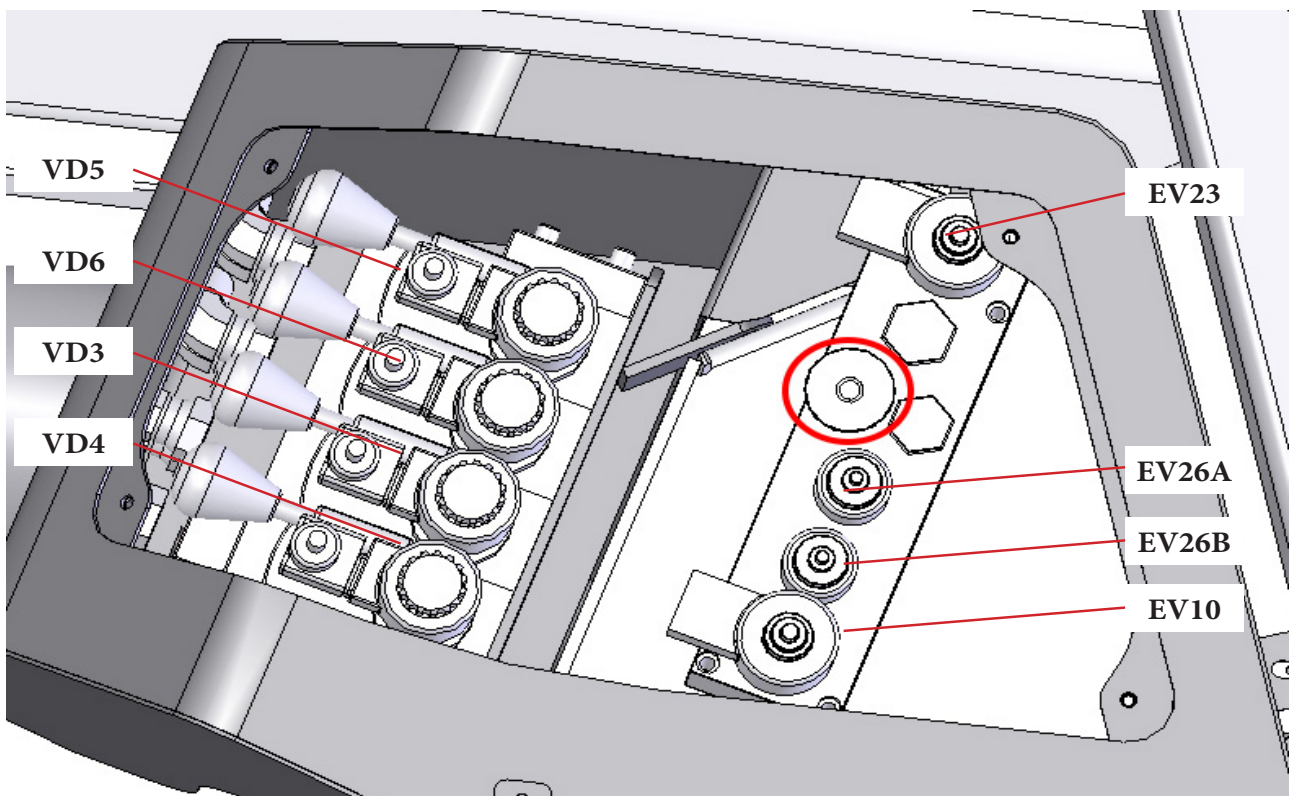

Fig. 4.4

- **Boom lowering**

To lower the boom, move the lever VD3 of the distributor and at the same time press the electrovalve EV23 (fig.4.4). Carry out the arm lowering maneuver until the basket is on the ground. The use of the emergency levers excludes all safety devices and therefore it is the task of the operator, specifically trained and authorized by the employer, not to carry out extension extensions or turret rotations

- **Turntable rotation**

To rotate the turret, use the lever VD5 of the distributor and at the same time press the electrovalve EV26A or EV26B depending on the desired direction of the movement. Every electrovalve works for one direction only, so if the maneuver doesn't work, be sure to press the right side.

Palazzani

INDUSTRIE



WARNING!

During the boom emergency movements, the basket leveling system is disabled, but the operator must do it manually acting on the electrovalve EV16; you have to unscrew the wheel and pull the central slider to have movement in one direction or the other

If you need to move the leveling only, keep pushed the electrovalve EV10 (fig.4.4) and at the same time the valve EV16. When the basket reaches the right level, you can release it. When the electrovalve EV10 is pushed manually, you can also press the valve EV15 to rotate the basket and EV17 to extent and retract the jib (Fig. 4.5).

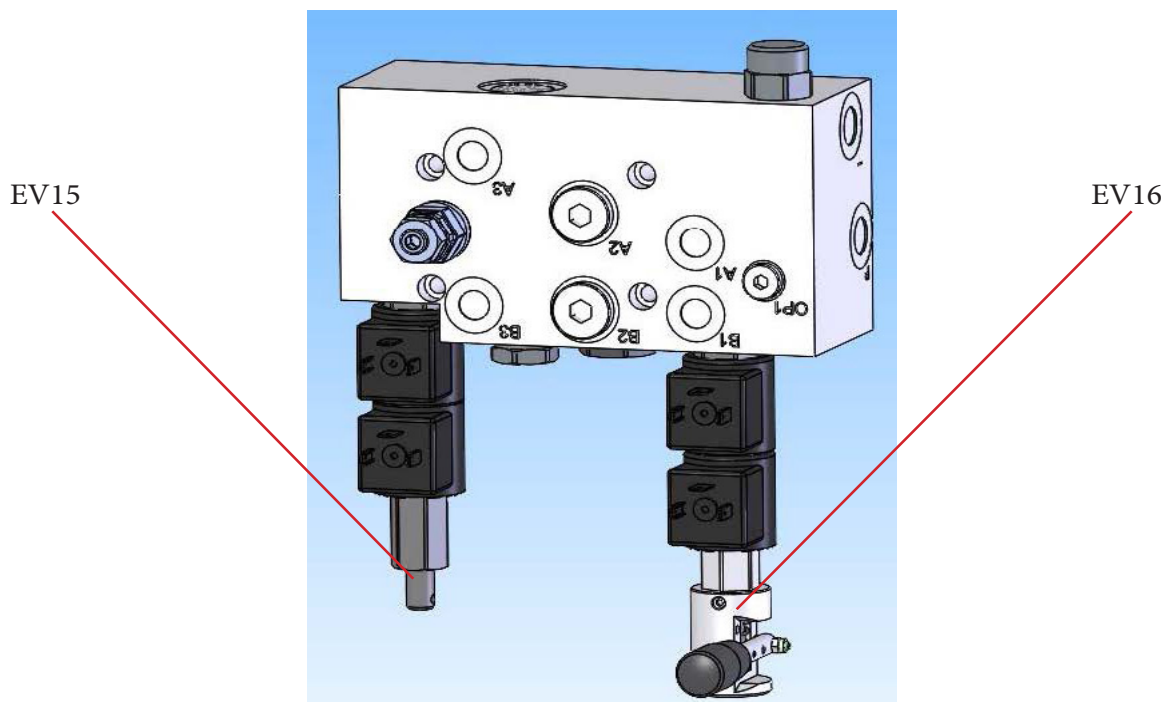

fig 4.5



When the operation is completed, notify the manager to have the machine checked by specifically trained personnel, also trying to report as much as possible about the manner or condition in which the inconvenience that forced the intervention occurred.



The manual insertion of the EV09 and EV23 solenoid valves must be justified on the register of the Manual attached to the machine and the valves must be unlocked and re-sealed before putting the equipment back into operation.

Unjustified tampering with these valves voids the manufacturer's responsibility.

Palazzani

INDUSTRIE

Recovery emergency with electric-pump

In case of a total breakdown including diesel and AC motors, it is necessary to generate the hydraulic power using the emergency electro pump.

This is a little pump connected directly to the batteries, it is useful in the emergency case to recovery the boom is there are no other energy sources available.

In order to recover the cage using the emergency pump, you need to close completely the tap indicated in picture 4.4 and keep pushed the button on the main electrical box (Fig. 4.6). Now follow all the instructions of the previous paragraph (Anomaly in the electric plant).



Fig. 4.6



WARNING

After using the emergency electro pump, please check the integrity and the voltage of the batteries.

Palazzani

INDUSTRIE

4.4. STABILIZERS RECOVERY

This operation is not included in the emergency procedures because the arm must have already been lowered and the people removed from the nacelle; however, it may be necessary to close the stabilizers for loading onto trucks to a repair shop.

Recovery has to be executed following this path:

1. Insert manually the valve EV09 (fig. 4.2).
2. Check that the spool of the valve EV3 (fig. 4.2) is activated or that the pin is unscrewed.
3. Insert EV06 by screwing the pin completely (fig. 4.7).
4. Operate the manual lever of the right track forwards from the distributor (VD2) and at the same time press one of the stabilizers electrovalves caps of EV11, EV12, EV13 ed EV14, one at a time until they are completely recovered. (Fig. 4.9).

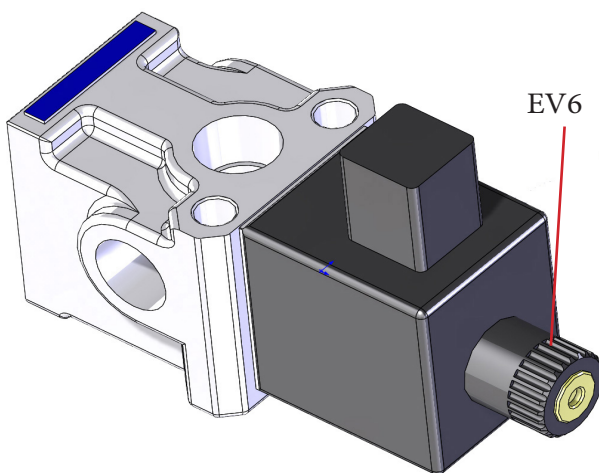

Fig. 4.7

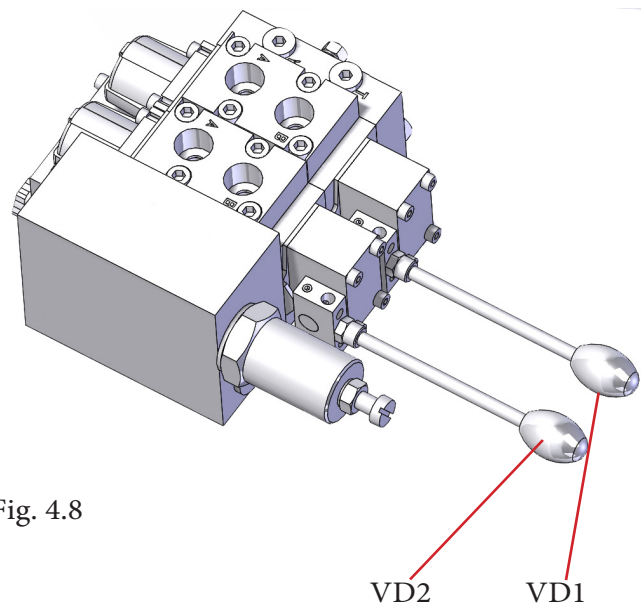

Fig. 4.8

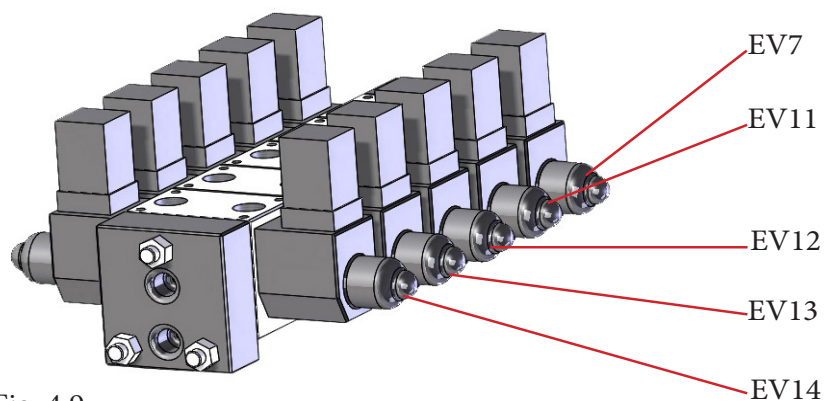

Fig. 4.9

Palazzani

INDUSTRIE

4.5. TRAVELLING

This operation also is not included in the emergency procedures, but sometimes it can be necessary to move the platform in order to not obstruct the passage.

- Follow the instructions of the previous paragraph till the point 2.
- Act on the tracks or wheels levers VD1 and VD2 on the distributor of picture 4.8 to travel.

4.6. QUICK TROUBLESHOOTING FOR THE OPERATOR



WARNING! If you notice a malfunction or irregular maneuvers of the equipment, use it only to bring it back to its rest position. Immediately notify your manager to have it checked by the personnel in charge of its maintenance.

If the machine doesn't turn on, verify that:

- There is current on the net.
- The main key of the machine is in ON position.
- There is fuel in the tank.
- The battery is connected and charged.
- The key rotates regularly in the main switch.
- All the emergency buttons of the machine are free.
- The condition needs a the special fuel additive for low temperatures.
- The AC switches are all in ON position.
- There are no system alarms on the display.

If the travelling doesn't work, verify that:

- The selector key is in the center.
- One or more stabilizers are on the ground.
- There are oil leaking or some components are damaged
- There are no system alarms on the display.

Palazzani

INDUSTRIE

If the boom movements don't work, verify that:

- The control panel on the ground is enabled (key pictures 3.1 position 2).
- The red lamp on the control panel is not switched on.
- The hydraulic oil level is good.
- All the stabilizers pin are correctly placed.
- The chassis angle is into the safety value (2°).
- All the stabilizers are on the ground with a good pressure.
- There are no system alarms on the display.

In case of vibrations or irregular movements, verify that:

- Telescopic boom sections are greased.
- The chains of the booms are regularly tensed and hydraulic oil level is regular.
- If the circuit has been opened for any repair, it is necessary to bleed the air by carrying out all the maneuvers up to the end of the stroke a couple of times.



A lot of checks can be made from the touch screen display on boards.
For further information about that, check the manual part regarding the display.

Palazzani

INDUSTRIE

5. MAINTENANCE AND CHECK-UP

Premise

It is recommended that the maintenance is carried out by personnel who:

- is specifically prepared
- knows the manual
- is authorized by the employer
- carry out the interventions according to the manufacturer's instructions and diagrams

Any intervention has to be carried out by:

- workshop authorized by the manufacturer
- expert personnel instructed by the manufacturer

Daily and weekly checks must be performed by trained and informed operators only. After any intervention check all the machine emergency functions.

5.1. ORDINARY MAINTENANCE - GENERAL INFORMATION

Advise for a correct maintenance, which guarantees long life performance:

- place the machine on level ground.
- take off the key or attach a sign saying "do not start the engine".
- disconnect the electrical supply from the machine if it is connected to the net.
- before to open the engine or the hydraulic system, ALWAYS clean the surrounding area.
- do not open a circuit or motor in the presence of contaminants.
- only use lubricants specified by the manufacturer.
- take into account reports received from operators to check for any irregularities; this is to check the safety conditions and not to aggravate a fault which then leads to much higher costs.
- do not use the equipment in case it has not been repaired completely or all the safeties are not operational.
- the maintenance worker as well as a capable person authorized by the employer must be familiar with this use and maintenance manual and have suitable clothing and personal protective equipment.
- do not use spare parts other than the original ones or in a way that does not comply with the manufacturer's specifications as in this case the maintenance technician will be completely responsible.
- do not change the intended use of the machine (eg use as a crane, as an elevator, etc.) since in this case the person who does it becomes the manufacturer.
- do not use this equipment for different purposes, as who does it, becomes its producer
- do not make any changes to the machine (larger basket, longer hand extension, more powerful motor, higher working speed, etc.) as even in this case, whoever does so becomes the manufacturer with all the resulting responsibilities.



Palazzani

INDUSTRIE

- respect the intervals indicated for carrying out scheduled maintenance operations and indicate them in the register starting from the quarterly one (those daily and weekly should not be recorded).
- mark any serious damage and related repairs in the attached register.

5.2. HYDRAULIC OIL / GREASE FEATURES

The oils used in this equipment are:

Hydraulic system	EQUIVIS ZS 46
Gearbox / bridges	GEAR EP LS SAE 85W/90
Chassis grease / turntable / pins	NILS WEGA 3
Boom grease	NILS WHITE STAR EP

Topping up using different oils is allowed but not recommended.

It is preferable to totally replace the oil contained in the equipment with another one in use by the user for reasons of warehouse stocks as long as it is of fairly similar characteristics.

We do not give names of alternative products due to the continuous and sudden replacement of the commercial name by the manufacturing companies.

Palazzani

INDUSTRIE

5.3. DAILY CHECK

Before starting any intervention, place the machine in the closed position, with the engine off, disconnected from the power source and possibly clean;

A DIRTY MACHINE DOES NOT ALLOW A CORRECT INSPECTION.

Check:

1. That no damage has occurred due to previous displacement or transport or parts are missing, there are no torn hoses, oil leaks, cut tires, disconnected electrical cables.
2. The battery charge by the indication on the display, red circle Fig. 5. If the voltage is lower than 21,5 V the display will shows the following screen with the information message (Fig 5).

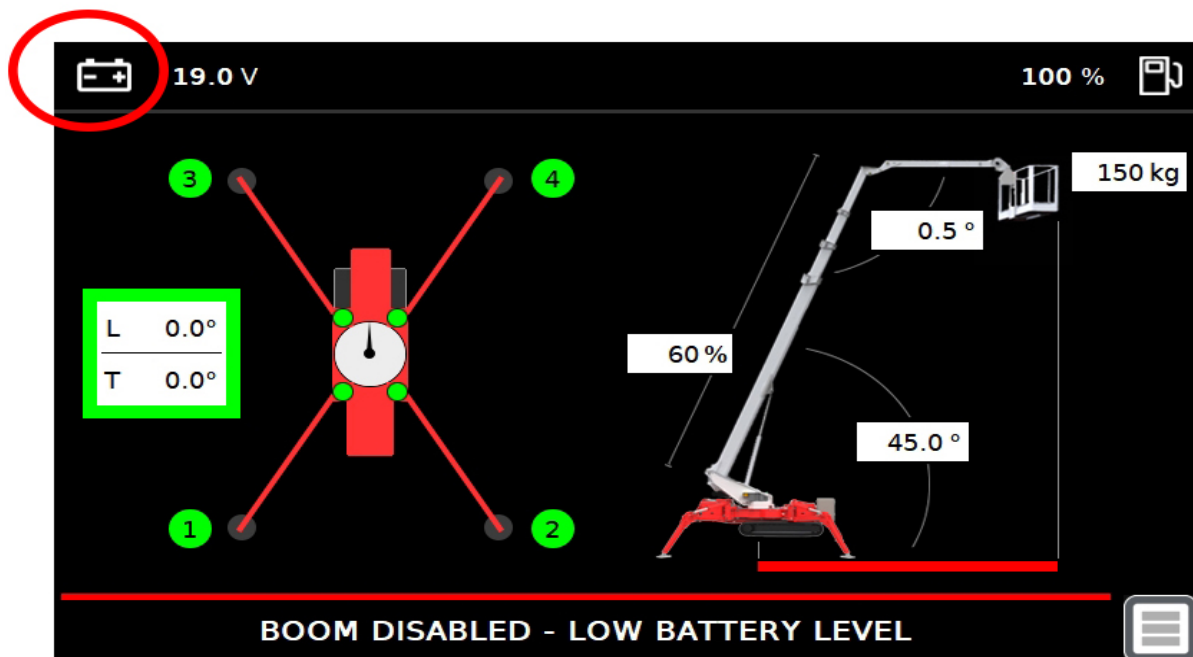

Fig 5

In this case:

- the buzzer in the turret will emit an acoustic warning
- the main boom extension and the lifting are blocked



WARNING

Consult the paragraph 5.11 before proceeding to recharge the batteries

Palazzani

INDUSTRIE

- The engine oil level through the engine stick (see the engine manufacturer manual attached) and the fuel level through the indicator Fig. 5.1

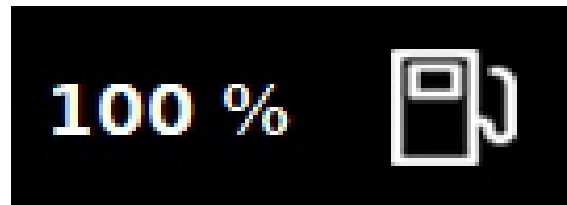

Fig 5.1

- Depending from the installed indicator, check that: the hydraulic oil level reaches the middle of the optic signal when the machine is in transport position with the indicator of Fig. 5.2a; or reaches the MAX value of the indicator of Fig. 5.2b.



Fig. 5.2 a



Fig. 5.2 b

- The interlock between stabilizers and arms: when the stabilizers are lifted up check that the arm maneuver can't be execute. When the stabilizers are set to the ground and the boom not in transport position, try to turn the key on the stabilizers symbol and check that the stabilizers do not move.

Palazzani



INDUSTRIE

6. Wide / narrow right side stabilizer limit switch test.

This check must be performed every time the stabilization phase is finished and before enabling the machine's air controls.

It is used to test the two limit switches that identify the wide positioning of stabilizers n ° 2 and n ° 4 (right side of the machine).

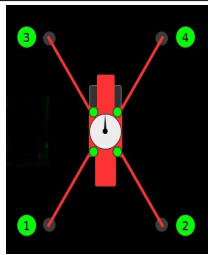
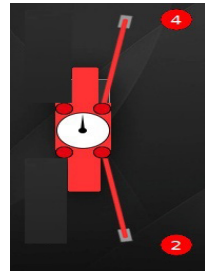
To perform the test, position the stabilizers as follows and check that the display shows the real configuration.

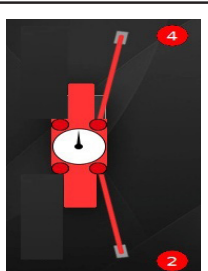
STABILIZER 2	STABILIZER 4	VISUALIZATION ON DISPLAY	
WIDE	WIDE		WIDE
WIDE	NARROW		NARROW
NARROW	WIDE		NARROW
NARROW	NARROW		NARROW



WARNING

Do not use the machine if the display does not show the real machine configuration.

Palazzani



INDUSTRIE

Wide / narrow left side stabilizer limit switch test.

This check must be performed every time the stabilization phase is finished and before enabling the machine's air controls.

It is used to test the two limit switches that identify the wide positioning of stabilizers n ° 1 and n ° 3 (right side of the machine).

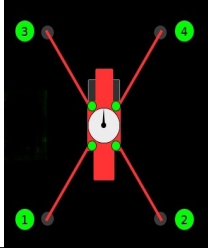
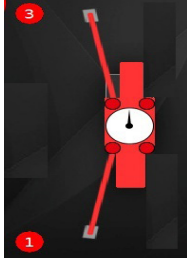
To perform the test, position the stabilizers as follows and check that the display shows the real configuration.

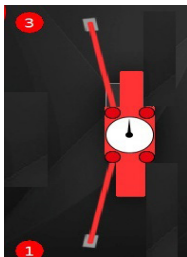
STABILIZER 1	STABILIZER 3	VISUALIZATION ON DISPLAY
WIDE	WIDE	 WIDE
WIDE	NARROW	 NARROW
NARROW	WIDE	 NARROW
NARROW	NARROW	 NARROW



WARNING

Do not use the machine if the display does not show the real machine configuration.

Palazzani

INDUSTRIE

7. The outreach limiting system in this way:
 - Set the stabilizers in the wide position.
 - With the boom horizontal on the engine side, extend the jib and extend the boom and verify that the maneuver stops when the outreach limiting system intervenes. In this condition the red lamp on the ground control panel must turn on and the extension and the lowering of the boom should not work.
 - Repeat the previous operation with the boom and jib removed from the opposite side of the engine and check the blocking of the extension, the blocking of the boom descent and of the rotation.
 - Set the stabilizers in the narrow position.
 - With the boom horizontal on the right side of the machine, extend the jib and extend the boom and verify that the maneuver stops when the outreach limiting system intervenes. In this condition the red lamp on the ground control panel must turn on and the extension and the lowering of the boom should not work.
 - Repeat the previous operation with the boom and jib removed from the left side and check the blocking of the extension extension, the blocking of the arm descent and of the rotation.
8. The emergency stop buttons positioned in every control position. When the emergency button is pressed, all movements of the machine must stop.
9. The sealing of the main boom locking valve as following: with the engine off and the boom in transport position (make sure that the basket does not touch the ground), open the hydraulic distributor cover, action the boom lowering lever (see sticker) and check if the boom remains motionless. If there's any movement, even slow, of the boom, do not use the machine
- 10.that moving the boom to the rest position (in the center, lowered and with the extensions completely in) the green light for the stabilizers consent is turned on. Verify also that in case of one condition is not satisfied (in the center, lowered and with the extensions completely in) the light turns off and the stabilizers movements doesn't work.
11. Check that the anchor points are not damaged / worn.

After any intervention check all the machine emergency functions.



IMPORTANT

It is recommended not to start the machine before checking that the control devices are functioning.

If the machine is used rarely, the check must be done before the machine is started.

Palazzani

INDUSTRIE

5.4. WEEKLY CHECK

The cleaning must be done weekly also to better find liquids leaking or loosened tightening.

Any intervention has to be carried out by:

- With the diesel engine running, check the value of the hydraulic pressure by sending a stabilizer to the end of the stroke during the return phase and checking if this corresponds to the plate value shown in chapter 1.
- Check the correct tightening of the chassis fixing screws (see table).
- the integrity of the extension boom chains and the connections (belleville washers, nuts and cotter pins)
- Check the tracks tension, (only for the tracked version). If they're inflected, it is recommended to put them under tension by using a greasing pump (6bar), as shown in Fig. 5.3. With the machine raised, adjust the yield of the track to 10-15 mm (Fig 5.3a).

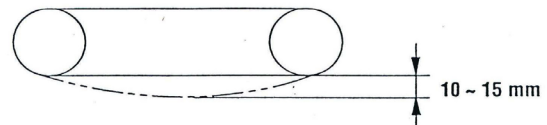
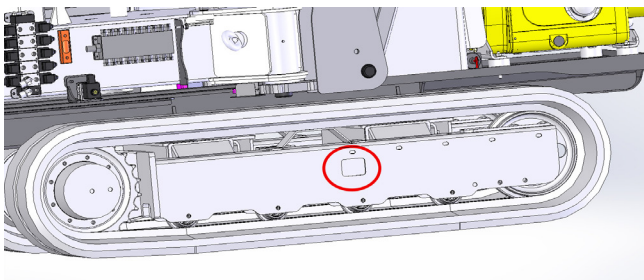

Fig.5.3

Fig.5.3a

- Check the level of the engine fumes and its noise level.
- Check the battery terminals and grease the positive pole. There must be no encrustations on the poles.
- Check the correct operation of the emergency electric pump (see chapter 4).
- Check the instruction plates are legible and not damaged, if not substitute them.
- Check that the ground and cage controls are functioning. Using the controls the movement must be correct.
- Grease all the articulations arms, cylinders, stabilizers and the cage. Before applying the greasing pump, clean the greasers and then keep on greasing until the old grease comes out.
- Execute all the checks as shown in the previous paragraph
- the right operation of the block valve on the boom lifting cylinder in this way:
 1. lift up the boom till about 10°
 2. switch off the engine and act on the lever of the boom lifting hydraulic distributor, alternately activating the boom lifting and lowering control; make sure that when pushing and pulling the distributor lever, the arm does not drop

Inform the responsible personnel about any failure encountered.

After any intervention check all the machine emergency functions.

Palazzani

INDUSTRIE

5.4.1. CHECKING AND MAINTENANCE OF THE AIR / OIL HEAT EXCHANGER (ONLY IN MODELS WHERE PROVIDED)

Cleaning oil side

After having dismantled the exchanger, carry out the cleaning procedure by circulating de-greasing substance inside the radiator compatible with aluminium. Wash with hydraulic oil before reconnecting the cooler.

Cleaning air side

Carry out this procedure using water or compressed air. Make sure that the direction of the jet is parallel to the fins so that they are not damaged.

In order to obtain optimal results during this type of procedure we advise using a cleansing agent.

If the blockage of the exchanger is caused by build up of oil or grease, cleaning can be carried out using a jet of steam or hot water.

During cleaning procedures the electric motor must be adequately protected.

Safety

During operation of heat exchangers observe following instructions:

- Do not remove the fan grilles.
- Electrical connections must be made by skilled electricians in accordance with the attached electrical diagrams.
- Exterior surfaces of heat exchangers may reach high temperatures so adequate guards must be installed or the unit must be mounted in an inaccessible position.
- Do not perform work on the hydraulic motor until the hydraulic pipelines have been disconnected.

Palazzani

INDUSTRIE

5.5. QUARTERLY CHECK

The quarterly check must be done when the machine is clean and has to be registered. The operator is recommended to wear gloves, glasses, proper clothes and to have his hair protected.

Pay attention when using compressed air or water under high pressure and check no other people are in that area; it is better that only one person make the ordinary check. If you are unable to finish the job, leave a sign on the machine prohibiting its use and remove the general key.

When removing covers from the diesel engine, the batteries and the main hydraulic circuit, it must be borne in mind that:

- The batteries are uncovered and therefore there must be no open flames or lit cigarettes and glasses must be worn
- The temperature in some parts may overcome the ordinary level, so it is recommended not to touch any part without gloves

It is recommended to execute these operations:

- Check the inspection register to verify the completeness of the previous maintenance operations
- Check all the safety devices electrically and mechanically like showed in the paragraph 5.13
- Daily and weekly execute all the maintenance operations.
- Grease the telescopic extensions of the arms using a brush
- Lubricate the chain for the boom extension with a brush and check it (see paragraph 5.12)
- Check the state of the oil in the tank: it must be coloured in light yellow; ; it must not have foam or have a milky color due to the presence of water
- Verify the absence of oil leaks or damage to flexible pipes in the articulations of the arms or inside the chassis (lift the machine on the stabilizers and look beneath the chassis)
- Check the oil levels and the amount of hours the engine has been running; therefore execute all the maintenance operations or the needed replacements. Clean the edge of the caps in order not to let powder in
- Check the level of the electrolyte in the batteries
- Inspect the arms next to the pivots or the sliding pads, in order to verify the absence of damages in the joints, maybe caused by crashes or by unusual vibrations
- Put the tracks (or wheels) under tension using the greasing pump (see previous chapter)
- Using a dynamometrical wrench, check the bolts/screws of the slewing (see the following table)

TIGHTENING TORQUES FOR HOLLOW HEAD SCREWS OR HEXAGONAL HEAD CLASSES OF BOLTS (METRIC THREADS - TRIANGULAR PROFILE - LARGE PITCH) WITH GEOMET 321 PLUS TREATMENT (ISO 16047)			
	8,8	10,9	12,9
	Tightening torque Nm	Tightening torque Nm	Tightening torque Nm
M 4	2	4	4
M 5	5	7	8
M 6	9	13	15
M 8	21	30	36
M 10	41	60	70
M 12	71	104	121
M 14	113	166	195
M 16	176	258	302
M 18	252	358	419
M 20	357	505	591
M 22	488	693	811
M 24	613	870	1018
M 27	903	1283	1502
M 30	1227	1742	2039
M 33	1663	2362	2765
M 36	2137	3036	3553
M 39	2769	3937	4607
M 42	3419	4869	5697
M 45	4273	6085	7122
M 48	5160	7349	8599
M 52	6636	9451	11060
M 56	8278	11789	13796
M 60	10272	14630	17120
M 64	12362	17607	20424

GEOMET. OPAQUE TREATMENT FOR WHEELBEARING FIXING SCREWS ONLY



**TIGHTENING TORQUES FOR HOLLOW HEAD SCREWS OR
HEXAGONAL HEAD
CLASSES OF BOLTS (METRIC THREADS - TRIANGULAR PROFILE -
LARGE PITCH) WITH GALVANIZED TREATMENT**

	8,8	10,9	12,9
	Tightening torque Nm	Tightening torque Nm	Tightening torque Nm
M 4	2	4	4
M 5	5	7	8
M 6	9	13	15
M 8	21	30	36
M 10	41	60	70
M 12	71	104	121
M 14	113	166	195
M 16	176	258	302
M 18	252	358	419
M 20	357	505	591
M 22	488	693	811
M 24	613	870	1018
M 27	903	1283	1502
M 30	1227	1742	2039
M 33	1663	2362	2765
M 36	2137	3036	3553
M 39	2769	3937	4607
M 42	3419	4869	5697
M 45	4273	6085	7122
M 48	5160	7349	8599
M 52	6636	9451	11060
M 56	8278	11789	13796
M 60	10272	14630	17120
M 64	12362	17607	20424



TIGHTENING TORQUES FOR HOLLOW HEAD SCREWS OR HEXAGONAL HEAD CLASSES OF BOLTS (METRIC THREADS - TRIANGULAR PROFILE - FINE PITCH) WITH GALVANIZED TREATMENT			
	8,8	10,9	12,9
	Tightening torque Nm	Tightening torque Nm	Tightening torque Nm
M 8	24	34	40
M 10	47	66	80
M 12	83	118	140
M 14	132	186	225
M 16	202	285	342
M 18	294	415	497
M 20	412	580	695
M 22	560	785	945
M 24	727	1023	1228
M 27	1018	1431	1718
M 30	1418	1995	2394
M 33	1904	2677	3213
M 36	2374	3338	4005
M 39	3066	4312	5175
M 42	3884	5462	6555
M 45	4819	6777	8132
M 48	5849	8267	9920

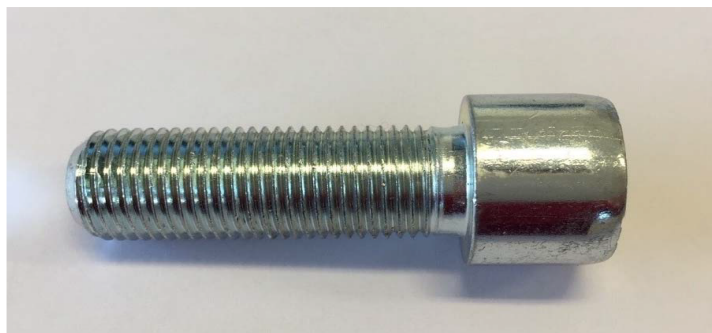

Palazzani

INDUSTRIE

- Check the oil level in the gearbox for the cage leveling by means of the special display Fig. 5.4 and Fig. 5.5.

When the display is in horizontal position, the oil level has to be halfway.
If not refill by means of the dedicated cap.

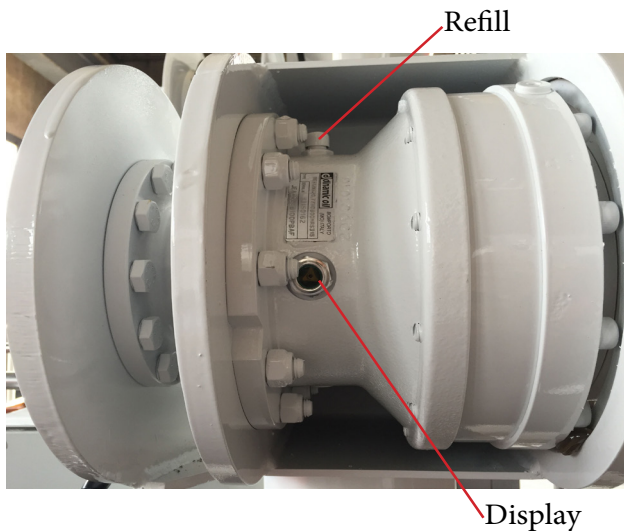

Fig. 5.4

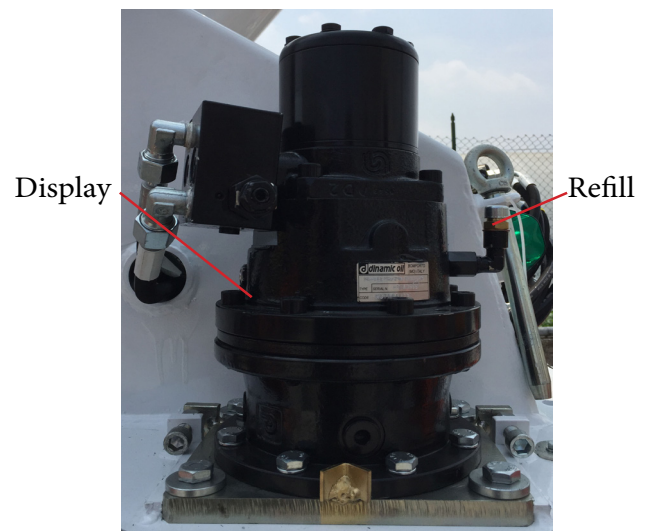

Fig. 5.5

- check that the rotation of the ball bearing does not have excessive play.
- Check the functioning of the microswitches (stabilizer pins, turret stabilization joints, arm at rest)

Palazzani

INDUSTRIE

- Check the correct functioning of the outreach limiting device in this way:
 - select the large position for all the stabilizer
 - set up the machine lifting up the tracks (or wheels) about 15/20 cm
 - remove every weight from the basket
 - open the jib and lower the boom horizontal
 - with the boom horizontal, extend it till the stop of the extension and the lowering of the boom
 - in these conditions, verify that the distance between the turntable center and the basket border (R1, look Fig. 5.6) is the same of the value written in the chapter 1 with a tolerance of 30 cm

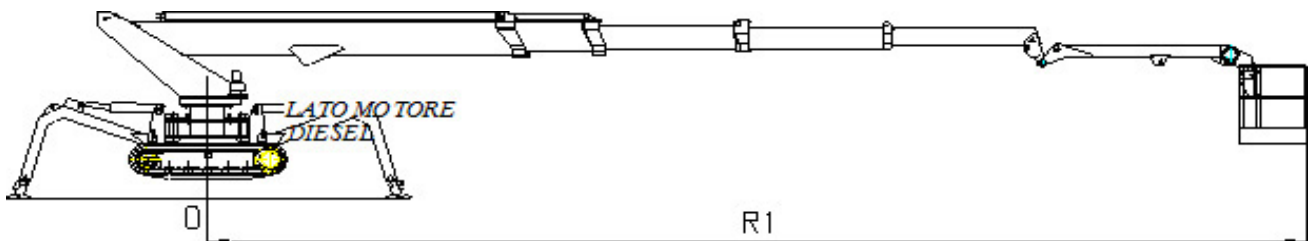

Fig. 5.6

After any intervention check all the machine emergency functions.



WARNING!

If during the check, the outreach is more than the value of the chapter 1, do not use the equipment and contact Palazzani Industrie.

Palazzani

INDUSTRIE

5.6. SIX MONTH MAINTENANCE

In addition to the quarterly checks, it is necessary to evaluate the situation and the environment where the machine operated, specially if it's close to the sea, if it worked in particularly aggressive environments or if the equipment remained outside subject to the weather.

- check if the hydraulic circuit flow has foam or has a dark coloration
- check the usury of the extension chains (paragraph 5.12) and grease them
- check the usury and the situation of the tracks (or wheels)
- check the welding, should not be rusty or have cracks
- check the conditions of the protection paint and, if necessary, fix it, in order to prevent rust
- Check the possible presence of paint blisters on the cylinders and on the arms and make sure they are not due to swelling or structural failure sure it is not because of any structural subsidence
- Set the engine following the proper manual
- Check the usury of the chromium plated stems of the cylinders, especially if near the sea
- Once the machine is parked and the engine is not running, check the stabilizers in search of any subsidence; the replacement must be instantaneous
- Check the indications on the control panels, the instruction plates and the emergency signs and replace the ones damaged
- refill the slowing gearbox and the tracks (or wheels) engines
- clean and check all the microswitches of the machine

After any intervention check all the machine emergency functions.



WARNING!

Notify the manager of any anomalies found.

Palazzani

INDUSTRIE

5.7. ANNUAL MAINTENANCE

Besides the checks described in the previous section, check the following:

- the chains tension and if necessary set them by acting on the bolts of Fig. 5.7; with the boom in horizontal position, extend it for 10 cm and re-entry; Loosen the upper bolts until the chain is loose and then screw until the chain becomes a little tight (for more details look the paragraph 5.12)
- grease the chains and check there is no rust (look paragraph 5.12)
- check the plays in the maneuvers: the arm in the turntable, the cage at the end of the arm, stabilizers in the support and between them, turntable.
- check that the slewing screws are well tightened

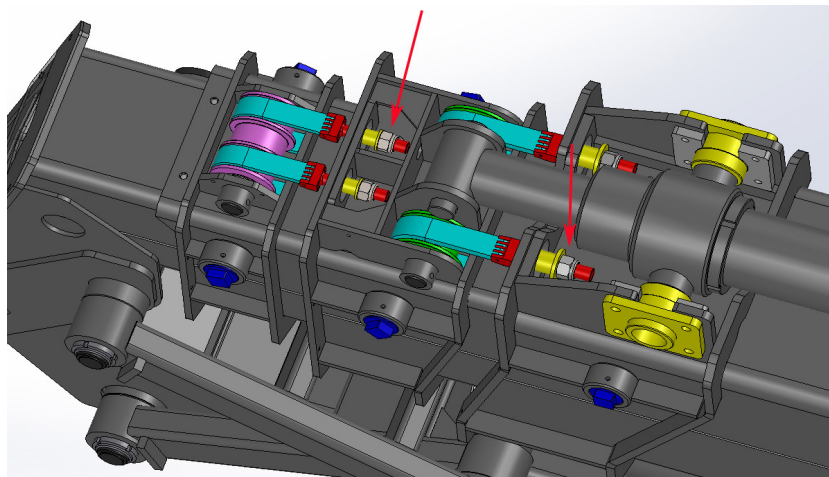

Fig. 5.7

- check the basket support and the usury of the basket leveling system bushings.
- replace the engine oil filters if not done previously following the producer's recommendations
- replace the flexible damaged pipes.

After any intervention check all the machine emergency functions.

Palazzani

INDUSTRIE

5.8. FOUR YEAR MAINTENANCE

Besides the recommendations in the previous paragraph:

- check the extension chains and if damaged, prepare them for replacement
- hydraulic oil replacement
- cylinders resistance and valves check. Put the cylinders under pressure and, after at least 1 hour, check that no subsidence has taken place
- check the cylinders stems surface
- check (replace only if necessary) of the flexible pipes.
- check the condition of the levers on the hydraulic distributors
- check the articulations pivots iron rings
- replace the turntable rotation gearbox oil
- filters replacement (cartridge)
- check the chains, particularly the boom connections and the not accessible areas. Substitute the defeated parts if any.

We remind you that these checks are just recommendations.

The operator must inform and the maintenance operator must provide for lubrication, refillments, replacements etc.

After any intervention check all the machine emergency functions.



WARNING!

Inform the responsible personnel of any problem encountered.

Palazzani

INDUSTRIE

5.9. EXTRAORDINARY MAINTENANCE

As described above, in hostile work conditions it may be necessary to anticipate the programmed maintenance operations. For example, the saltiness damages on paint, chains, cylinders stems; the wind, when carrying sand, may damage the hydraulic oil or the control panels. It is also recommended not to leave the machine outside for a long time: water may penetrate and damage electric equipment and cause rust.

In other situations too the operator must intervene immediately: pump replacement, perforated tyres, damage of flexible pipes, damage of batteries, weldings, etc ...

In case of battery damage we recommend the maximum care because the electrolyte is dangerous for people and for the environment.

Wear glasses to avoid squirts into the eyes and wear gloves to avoid skin damage.

Use these protections also when treating oil. The oil acts as human fat solvent and a constant exposition to it may cause dermatitis or serious irritation. In case of any contact with the eyes rinse copiously with water and if the irritation persists, contact a doctor.

Moreover, before manipulating these products, read carefully the producer's recommendations about its usage.

Before welding, disconnect both poles of the battery; also connect the ground on the element where the welding is to be carried out and never on an element of the hydraulic circuit.

After any intervention check all the machine emergency functions.

Palazzani

INDUSTRIE

LUBRICATION SCHEME

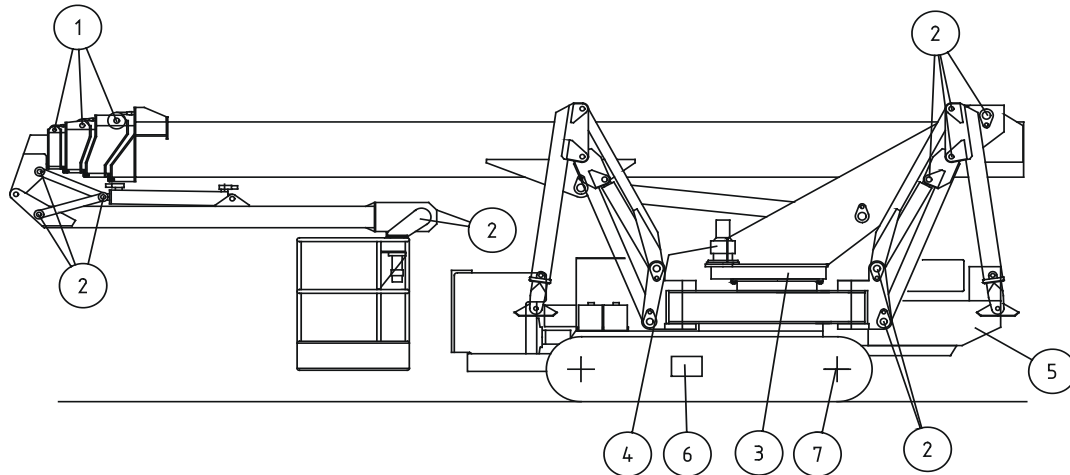

- 1) SLIDING PADS GREASING
Lubricant NILS WHITE STAR EP
- 2) VARIOUS PIVOTS GREASING
Lubricant NILS WEGA 3
- 3) SLEWING GEAR GREASING
Lubricant NILS WEGA 3
- 4) ROTATION GEARBOX
Lubricant GEAR EP LS SAE85W/90
- 5) HYDRAULIC OIL TANK
Lubricant EQUIVIS ZS 46
- 6) TRACKS TENSIONER
Lubricant AUTO GREASE MP
- 7) TRACKS MOTORS (OR WHEELS)
Lubricant GEAR EP LS SAE85W/90



WARNING

Do not lubricate in correspondence with the tracks covered by the lifting arm sliding shoes made of blue / purple material (Fig. 5.8).



Fig 5.8

Palazzani

INDUSTRIE

5.10. CHECK OF HYDRAULIC CIRCUIT

These are the recommended checks for the hydraulic circuit:

- oil in the tank: through the level visually
- diesel engine pumps efficiency: when the engine is running, switch the control key to “stabilizers”, activate a stabilizer until it is completely retired and check that the pressure is within the maximum value shown in chapter 1. When the stabilizers are under pressure, start the generator and check that the voltage is 230V + 10%.
- electric engine pump efficiency. When the engine is running, switch the key to “stabilizers” and move a stabilizer until it’s completely retired; then check than the pressure value is within the maximum shown in chapter 1.
- filter efficiency. Open the engine cover and after a few minutes (10 minutes during the cold season) check the indicators are not on the red.
- maximum pressure valves. Using the thermal engine and moving the arms until they’re completely retired, the manometer should show the maximum value as shown in chap 1.
- flexible pipes: check if they’re not damaged or blistered near the hose fitting, damages in the metallic/textile stranded wire or permanent foldings. The black surface film sealing is not dangerous for the pipe
- cylinders locking valves. Put the stabilizer cylinders under pressure, as soon as the lifting cylinder is raised, the jib is fully open (and then completely closed): mark the stems with a tape and measure the distance from a point (as the flange thread) to the plaster; the permissible settlement is null after 1/4 of an hour, 1 mm after 1 hour
- Oil leaks: Maximum allowed is few on the stems and on the spiral pipes.

After any intervention check all the machine emergency functions.

Palazzani

INDUSTRIE

5.11. GENERAL ELECTRIC SYSTEM AND BATTERY RECHARGER CHECK

When using the electric motors, the machine mounts a buffer rectifier for charging the batteries, placed inside the rear casing (box1).

This rectifier is automatically powered by the plug connected to the el. net for the operation of the equipment.

The diesel engine also contributes to recharging when it is running.

It is therefore necessary to keep the electrolyte level in the batteries checked and the positive poles greased.

	<p>WARNING</p> <p>In the event of long periods of inactivity of the machine, the starter batteries may lose their charge level. To restore the batteries to their working state, you can connect the plug connected to the el. net and automatically use the rectifier mounted in the machine. Sometimes the rectifier (in case of too low battery level) is not able to recharge the system.</p> <p>In this case there are various methods to restore the state of charge:</p> <ul style="list-style-type: none"> - replace the batteries - remove the batteries from the machine and charge them with an external battery charger - connect external batteries in parallel to those of the machine and try to start the diesel engine which in turn will try to bring the battery back to the correct charge value. <p>It is strictly forbidden to charge the batteries with external chargers without having first removed them from the machine. It is absolutely forbidden to start the diesel engine with tools such as BOOSTER or STARTER. Failure to comply with the aforementioned indications can cause SERIOUS DAMAGE to the electrical components of the machine.</p>
--	--

	<p>WARNING</p> <p>It is absolutely forbidden to weld metal parts on the machine without having disconnected the batteries and ALL electronic components.</p>
--	---

We have seen in the previous pages the need to periodically check the correct functioning of safety devices, many of which are of an electrical nature, also simulating maneuvering errors.

Palazzani

INDUSTRIE

Very often checking the electrical system coincides with the search for a fault, as these components are the part most exposed to damage due to rain, dust, vibrations, etc. The maintenance technician / mechanic must be particularly prepared but above all precise and respectful of the electrical components and their connections.

Let's remember a few things:

- the microswitches, the relays, the diode valves and the condensers may be similar but connected each other in different ways. We recommend to replace them with parts that has the same brand and the same code; try to remember the coloured of the cables or the terminal numbers not to make connections mistakes
- do not take off more than one relay at a time, check it and if necessary replace it with an equal one
- the microswitches have a symbol representing a little arrow inside a circle or this P. They're just in case of emergency and cannot be replaced with other similar parts which do not have these symbol
- Be careful with NA or NC connections
- Always re-connect the grounding cables and the equipotentiality cables
- The emergency stop buttons must be repaired immediately when a failure is encountered.
- Follow carefully the scheme and do not operate any modification that may damage or affect the entire machine functioning.
- After any intervention check all the machine emergency functions.

N.B. The access to the inside of the electric plant wrappings is recommended to be executed by instructed personnel only.

Palazzani

INDUSTRIE

5.12. CHAIN CHECK

The chains for the extension of the telescopic extensions are of the Fleyer type specially designed for this job; for safety reasons they are mounted in pairs with separate attachments and a device that ensures almost the same pull on the two chains. As safety-related elements, chains require scheduled maintenance and periodic checks on a quarterly basis.

Maintenance

For correct operation of the chains and the coupled sliding elements, adequate lubrication conditions must always be maintained.

To lubricate the chains, extend the arm completely horizontally, taking care to support it at the end with an overhead crane or a crane of adequate capacity (see Fig. 5.9). In this way the extension chains are accessible for maintenance and checks.



Fig. 5.9

The lubricant has two main tasks: Action anti-friction, protective action.

The lubricant is usually applied by brushing on the surface of the plates; it must penetrate between one plate thickness and the other in order to also reach the wear area between the pin and plate holes.

If the chain is contaminated by abrasive particles (eg sand), before lubricating it is necessary to thoroughly clean it by washing with a suitable solvent. Lubricating the dirty chain would in fact push the abrasive material into the joints, triggering abrasive wear phenomena.

NILS VFE 2000 oil can be used for lubrication.

A very fluid oil penetrates the joints better, but resists less in the joints, than more viscous lubricants. A very viscous compound, on the other hand, has difficulty in penetrating the joints and therefore may not allow the desired lubricating effect.

It is very important, in the case of operation in an aggressive environment (eg saline atmosphere), to keep the surfaces well protected to limit oxidative phenomena that are particularly dangerous for the external plates, which may be subject to cracks due to “ stress corrosion” phenomena. In these cases, to give greater protection to the chain, after having lubricated with relatively light oil, it is possible to spread over the entire surface highly adhesive grease with water-repellent characteristics.

Palazzani

INDUSTRIE

It is not possible to precisely define the lubrication periodicity. In fact, it varies according to the frequency of use, the type of lubricant and the method of application, the work environment, etc.

However, it can be said that the time interval between one lubrication and the other must not exceed 12 weeks or 200 hours of work.

Check

At each lubrication operation, the chain tensioning systems must be adjusted, if necessary, and check for any anomalies in alignment between the chain, attachment system and pulleys. Misalignments are very dangerous because they can induce high overstresses on the chains.

Check for wear elongation

To keep elongation due to wear under control, a registration form must be prepared. Since it is likely that the wear will not be uniform over the entire length, the measurement must be carried out in sections (divide the length of the chain into 5 sections) which must be suitably identified.

The initial measurement must be taken which serves as a reference for the subsequent ones and it must be borne in mind that all subsequent measurements must be made on the same section. After some measurements it is possible to identify which sections are most subject to wear and therefore subsequent measurements may be limited only to these traits.

The measurement can be made on slide gauge long enough or line graph. The reference may be either the head of the pins or the profile of the plate.

The maximum elongation is conservatively set at 2%.

Check wear plates profile

After identifying the length of chain where this phenomenon is more evident, with a gauge should be recognized the actual height of the plate eyelet and compared with the initial one. The following maximum acceptable wear limits are set (see Fig. 5.10):

$$\begin{aligned} \text{Wear on one side} & \quad [(H - H1) / H] \times 100 < 2\% \\ \text{Wear on two sides} & \quad [(H - H2) / H2] \times 100 < 3.5\% \end{aligned}$$

The high specific pressures between the plate and pulleys can cause plates, as well as wear, even consummation of the material on the edge of the plate that can lead to blocked joints. If you encounter locked joints, the chain must be replaced.

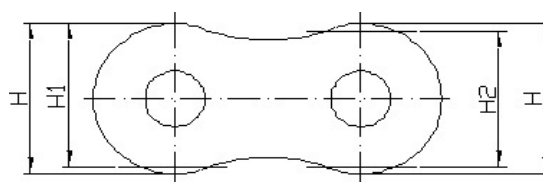

Fig. 5.10

Wear on the side of the chain

This wear is caused by improper interaction with the chain pulleys or guide elements side. If the consumption over the heads of pins exceed 25% of the riveting protrusion or on the external side of the plate more than 20% of the thickness (see Fig. 5.11), the chain must be replaced before applying the new, the cause of this malfunction must be sought.

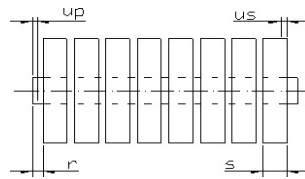

Fig. 5.11

Percentage consumption of the pin head	$up / r \times 100 < 25\%$
Percentage consumption on the plate edge	$us / s \times 100 < 20\%$

These checks should be performed every 3 months.

After four years the chains must be dismantled and inspected in the attacks on the arm and in areas not normally accessible and, if damaged, replaced.

After any intervention check all the machine emergency functions.

Palazzani

INDUSTRIE

5.13. SAFETY DEVICES CHECK

Various electronic safety devices are installed on the machine which require periodic checks and maintenance.

MECHANICAL CHECK OF MICROSWITCHES AND SENSORS

For every microswitch, check:

- 1) the integrity of the microswitch head and clean it from dirt
- 2) the right tightness on the fixing screws
- 3) the right electrical connection (by plug or wires)

The following safety limit switches are installed on the machine:

- n°4 limit switch support stabilizer on the ground (Fig. 12 - A)
- n°4 narrow / wide stabilizer position limit switch (Fig. 12 - B)
- n°4 limit switch stabilizer pins (Fig. 12-C)

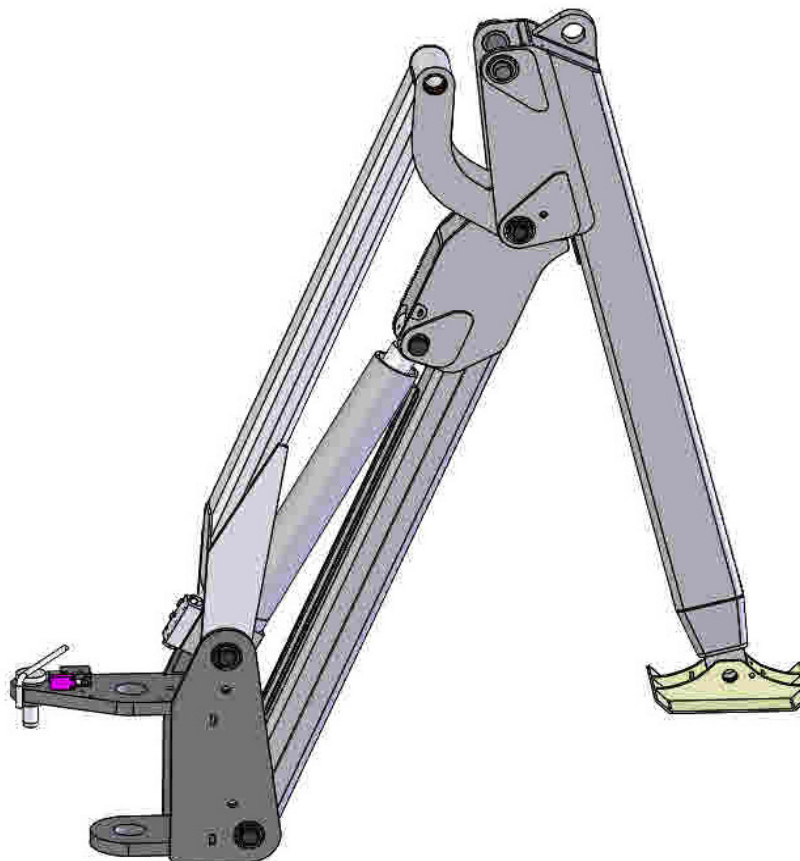

Fig. 5.12

Palazzani

INDUSTRIE

- **Limit switch support stabilizer on the ground (Fig. 5.13)**

The head of the microswitch must be free when the stabilizer is on the ground and it must be pressed when the stabilizer is lifted.

- **Narrow / wide stabilizer position limit switch (Fig. 5.14)**

The head of the microswitch must be free when the stabilizer is in the wide position and it must be pressed when the stabilizer is in the narrow position.

- **Limit switch stabilizer pins (Fig. 5.15A, 5.15B)**

The head of the microswitch must be free when the pin is in, and it must be pressed when the pin is out.

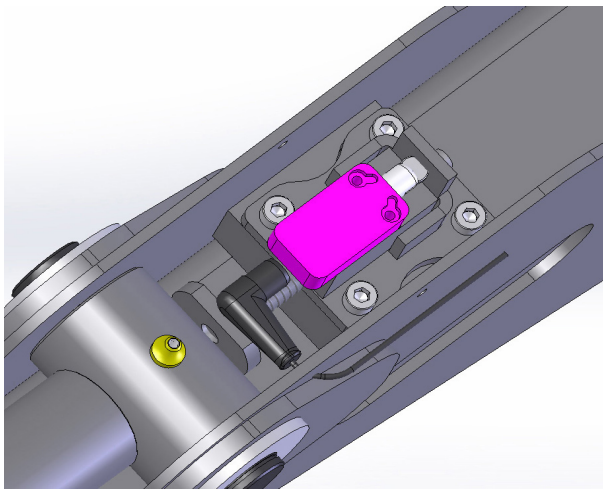

Fig. 5.13

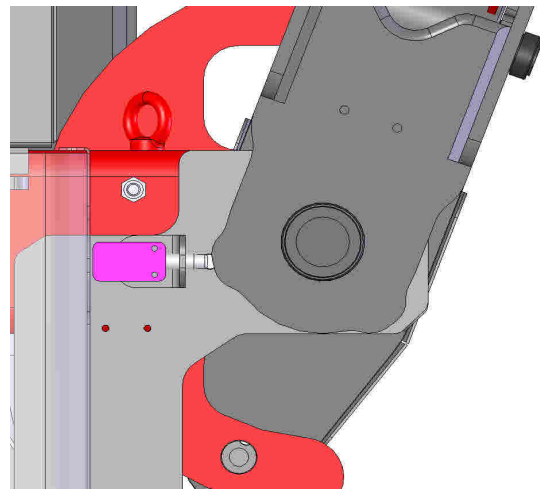

Fig. 5.14

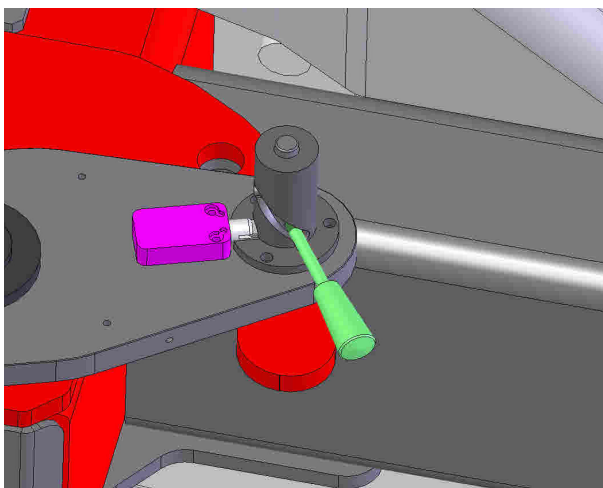

Fig. 5.15A

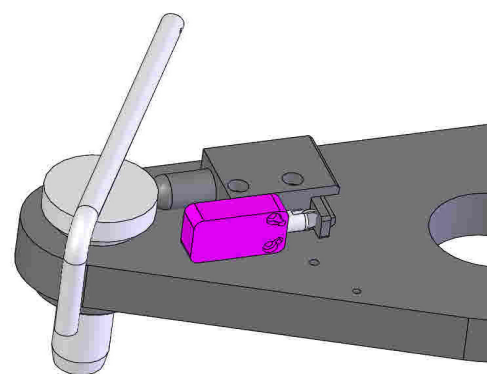

Fig. 5.15B

Palazzani

INDUSTRIE

There are two safety sensors on the machine to be monitored:

- turntable encoder
- extension sensor

- **Turntable encoder**

check the two encoders dismounting the cover located on the side of the turret (Fig.5.16). The nylon gear connected to the sensor must be tightly screwed without showing excessive play or signs of wear. Tighten all screws and clean from any dirt.

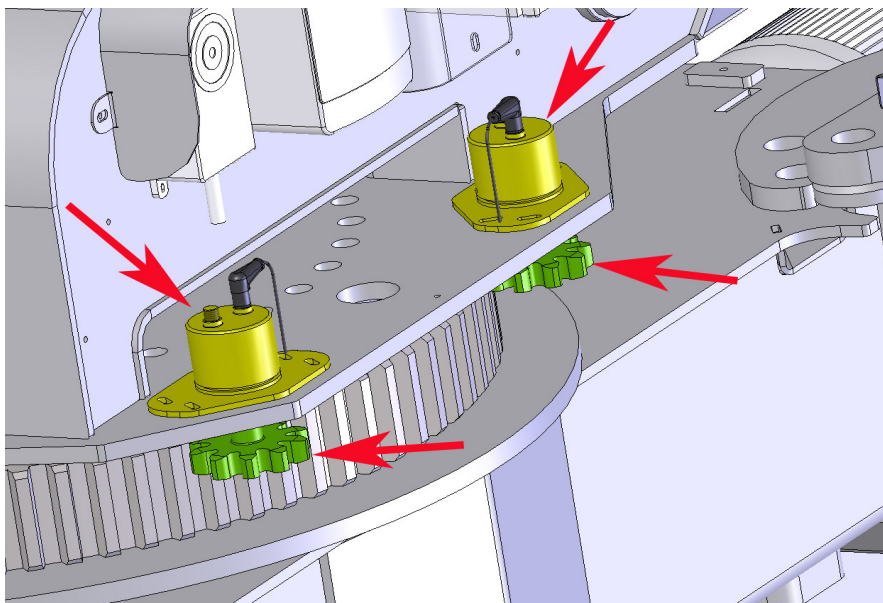

Fig.5.16

For machines equipped with endless screw, check the correct tightening of the encoder applied to the rotation block as shown in Fig. 5.17.

Carefully check the integrity of the connecting shaft between the encoder and the rotation system; if there are deformations or cracks, do not use the equipment and contact Palazzani Industrie or an authorized workshop.

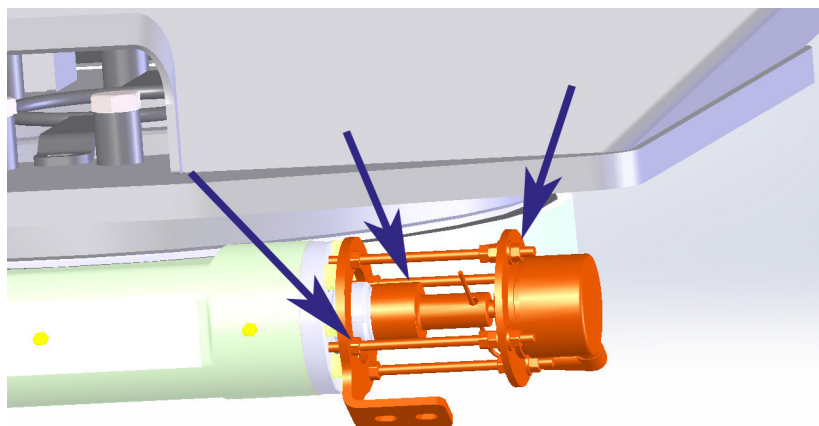

Fig. 5.17

Palazzani

INDUSTRIE



WARNING:
Replace the encoder after 10 years.

- **Boom extension and angle sensor**
a sensor is mounted inside the arm which has the task of measuring the extension and angle of the arm (Fig. 5.18). Check the tightness of the sensor screws, integrity of the alluminium tape and the connection between the tape and the first extension.
Clean the tape of any material that may prevent it from functioning properly.

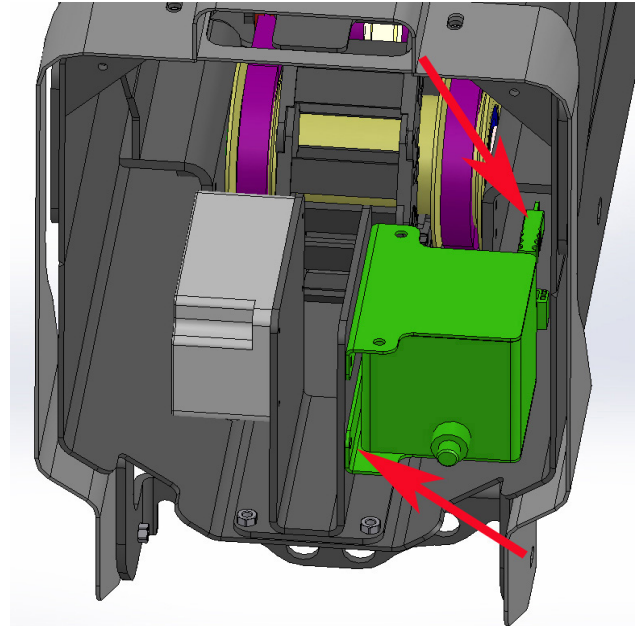

Fig. 5.18



WARNING:
Replace the boom sensor after 10 years.

Palazzani

INDUSTRIE

ELECTRICAL CONTROL OF LIMIT SWITCHES AND SENSORS

To test the correct electrical operation of the limit switches and sensors of the machine, it is possible to use the touch screen display of the machine. To view the test pages, press the INDEX key (Fig. 5.19) and then TEST (Fig.5.20)

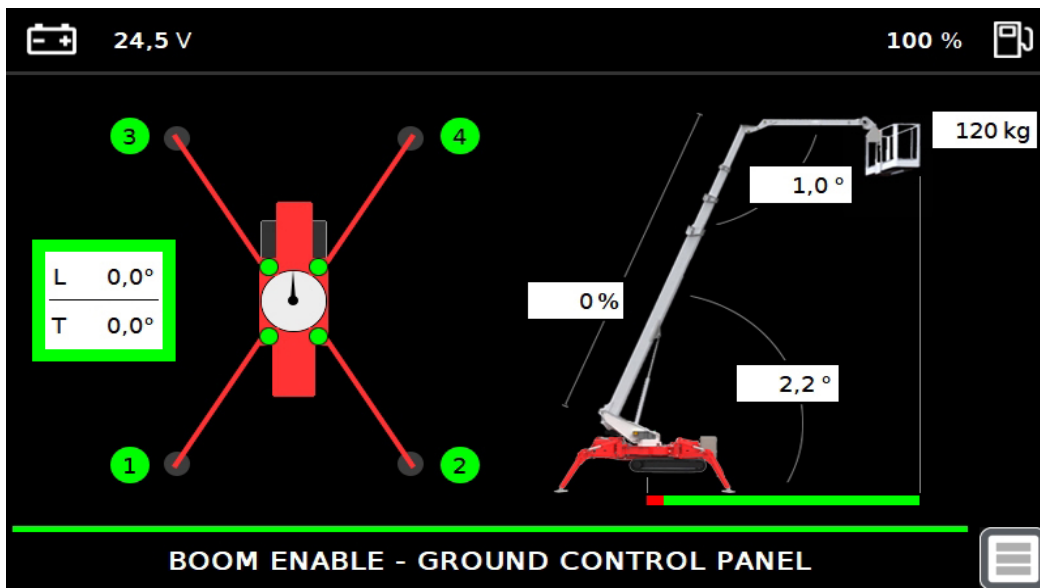

Fig 5.19

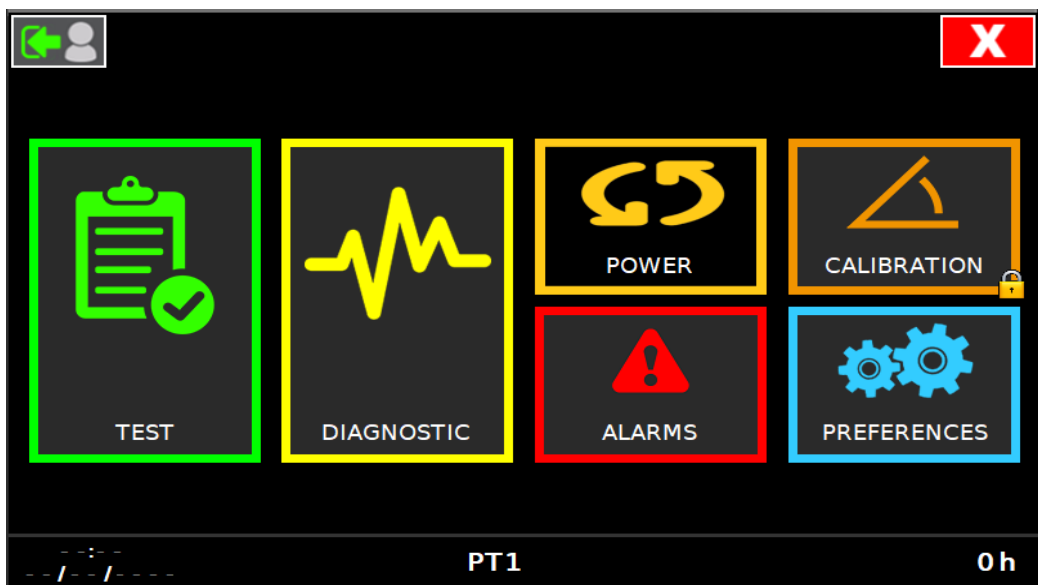

fig 5.20

Palazzani

INDUSTRIE

From the limit switch test page (Fig.5.21) it is possible to check the correct operation of the following devices:

- stabilizer 1 limit switch on the ground
- stabilizer 2 limit switch on the ground
- stabilizer 3 limit switch on the ground
- stabilizer 4 limit switch on the ground
- right side stabilizer positioning limit switch
- left side stabilizer positioning limit switch
- stabilizers pins
- notable arm point
- FN key
- fully retracted jib (XTJ models only)

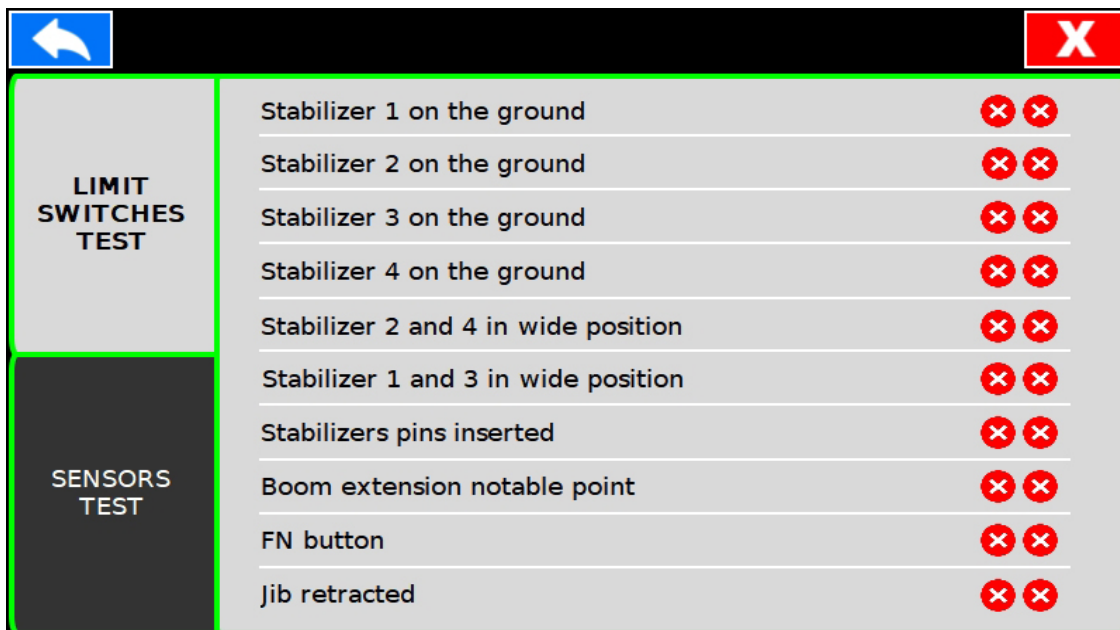

Fig 5.21

• Stabilizer 1 on the ground

To carry out the test, position the stabilizer 1 as follows and check that the two symbols on the side correspond to the following table in both conditions indicated.





STABILIZER 1 ON THE GROUND	✓ ✓
STABILIZER 1 LIFTED	✗ ✗

Palazzani

INDUSTRIE





- **Stabilizer 2 on the ground**

To carry out the test, position the stabilizer 2 as follows and check that the two symbols on the side correspond to the following table in both conditions indicated.

STABILIZER 2 ON THE GROUND	 
STABILIZER 2 LIFTED	 





- **Stabilizer 3 on the ground**

To carry out the test, position the stabilizer 3 as follows and check that the two symbols on the side correspond to the following table in both conditions indicated.

STABILIZER 3 ON THE GROUND	 
STABILIZER 3 LIFTED	 









- **Stabilizer 4 on the ground**

To carry out the test, position the stabilizer 4 as follows and check that the two symbols on the side correspond to the following table in both conditions indicated.

STABILIZER 4 ON THE GROUND	 
STABILIZER 4 LIFTED	 

- **Stabilizer 2 and 4 in wide position**

To perform the test, position the stabilizers as follows and check that the symbols shown correspond to the following table in all four conditions









STABILIZER 2 WIDE	STABILIZER 4 WIDE	 
STABILIZER 2 WIDE	STABILIZER 2 NARROW	 
STABILIZER 2 NARROW	STABILIZER 2 WIDE	 
STABILIZER 2 NARROW	STABILIZER 2 NARROW	 

Palazzani

INDUSTRIE





- **Stabilizer 1 and 3 in wide position**

To perform the test, position the stabilizers as follows and check that the symbols shown correspond to the following table in all four conditions.

STABILIZER 1 WIDE	STABILIZER 3 WIDE	 
STABILIZER 1 WIDE	STABILIZER 3 NARROW	 
STABILIZER 1 NARROW	STABILIZER 3 WIDE	 
STABILIZER 1 NARROW	STABILIZER 3 NARROW	 





- **Stabilizers pins inserted**

To test the stabilizer pins, check that in the following conditions the two symbols shown on the screen correspond to the following table.

ALL THE PINS INSERTED	 
ONE PIN NOT INSERTED (MAKE THIS TEST WITH ALL THE PINS)	 





- **FN key**

To test the FN key, check that in the following conditions the two symbols shown on the screen correspond to the following table.

FN BUTTON PUSHED	 
FN BUTTON RELEASED	 

- **Jib full retract**

To carry out the jib limit switch test, check that in the following conditions the two symbols shown on the screen correspond to the following table.

JIB RETRACT	 
JIB EXTENDED	 



WARNING!

Inform the responsible personnel of any problem encountered.

By clicking on SENSOR TEST you can access the pages to check the correct operation of all the safety sensors (Fig.5.22 and 5.23)

				X	
LIMIT SWITCHES TEST	Chassis long. angle [°]	0.0	0.0	Target:	0°
				Max diff:	0.0°
	Chassis trasv. angle [°]	0.0	0.0	Target:	0°
				Max diff:	0.0°
	Turret encoder	0	0	Target:	0
				Max diff:	0
SENSORS TEST	Boom angle [°]	0.0	0.0	Target:	0°
				Max diff:	0.0°
	Boom extension [%]	0.0	0.0	Target:	0/100%
				Max diff:	0.0%
	Basket load [Kg]	0	0	Target:	0 Kg
				Max diff:	0.0 Kg

Fig 5.22

• **Chassis longitudinal angle**

Follow these instructions to check the inclinometer on the chassis:

- 1) stabilize the machine perfectly flat with the help of the toric bubble placed on the chassis
- 2) check the two longitudinal angles from the video

The difference between the two angles can't exceed the value indicated with "Max. diff".

• **Chassis transversal angle**

Follow these instructions to check the inclinometer on the chassis:

- 1) stabilize the machine perfectly flat with the help of the toric bubble placed on the chassis
- 2) check the two transversal angles from the video

The difference between the two angles can't exceed the value indicated with "Max. diff".

Palazzani

INDUSTRIE

- **Turntable encoder**

Follow these instructions to check the encoders on the turntable:

- 1) move the boom perfectly in the center
 - 2) now from the display, check the encoder values: both must be around the reference.
- The difference between the two values can't exceed the "Max. diff".

- **Boom angle**

Follow these instructions to check the inclinometer on the boom:

- 1) position the main arm at 0 ° perfectly horizontal with the help of an inclinometer
 - 2) now from the display, check the angle values: both must be around the reference.
- The difference between the two angles can't exceed the value indicated with "Max. diff".

- **Boom extension**

Follow these instructions to check the extension of the boom:

- 1) retract completely the boom
 - 2) check from the display the extension values, both must be around 0.
 - 3) extend completely the boom in the vertical position
 - 4) check from the display the extension values, both must be around 100%.
- The difference between the two extensions can't exceed the value indicated with "Max. diff".

- **Basket weight**

Follow these instructions to check the basket load sensor:

- 1) remove everything from the basket (it must be empty)
 - 2) from the display, check the values of the sensor in the basket: both must be around the reference.
- The difference between the two weights can't exceed the value indicated with "Max. diff".



WARNING!

Inform the responsible personnel of any problem encountered.

Palazzani

INDUSTRIE

6. PLATFORM ASSIGNMENT AND DEMOLITION

6.1. ASSIGNMENT

In case of transfer of the machine to another user, it must be remembered that in relation to the new purchaser the old owner becomes the manufacturer by law if he has made changes to the original machine.

If he has not made any changes, he must deliver it in an absolute state of efficiency both as regards the safety devices, the operating controls and the integrity of the structures.

It is also essential to deliver this “Use and Maintenance Manual” and the Declaration of Conformity because it is an integral part of the machine.

He must check that the warning and instruction plates are still legible on the machine and that the CE mark is not missing.

6.2. DEMOLITION

6.2.1. WASTE MATERIAL DISPOSAL

The machine, during its normal use, doesn't involve environmental contamination but during the complete use period it produces some waste material in particular conditions, like oils and the filter replacement or the oil filling.

For the disposal of these materials, there are specific regulations in each country for the protection of the environment.

It is the customer's obligation to be aware of the laws in force in his country and to operate in such a way as to comply with these laws in accordance with the indications given on the technical data sheets of the products used.



WARNING

WE RECALLS OBSERVANCE OF APPLICABLE LAW OF MINERAL OIL DISPOSAL



SUPPLEMENTARY INFORMATION

ADDITIONAL INFORMATION ABOUT THE DISPOSAL OF OILS CAN BE FOUND ON THE SAFETY DATA SHEET OF SUBSTANCES.

Palazzani

INDUSTRIE

The disposal of toxic waste in stages of collection, transport, treatment, understood as processing operation necessary for the recovery, activity is of public interest subject to compliance with the following general principles:

- Any damage or danger to the health, safety and safety of the community and individuals must be avoided.
- It must be ensured that the requirements of hygiene and avoid any risk of pollution of air, water, soil and subsoil.

Systems of recovery and recycling of materials and energy must be promoted, in compliance with economic and efficient criteria.

6.2.2. INDICATIONS FOR SPECIAL WASTE

The residues deriving from industrial processes, the materials deriving from the demolition of deteriorated and obsolete machinery and equipment are special waste. With regard to the disposal of special waste, even toxic and harmful, the producers of the waste themselves are required to provide, directly or through companies, authorized bodies or by transferring the waste to the subjects that manage the public service with whom a specific agreement has been stipulated. Each country / municipality is required to provide the region with all the information it has available on the disposal of waste in its territory.

IMPORTANT INFORMATION FOR THE USER UNDER DIRECTIVE “RAEE” 2012/19/UE (REPEALING DIRECTIVE 2002/96/CE AND THE 2003/108/CE) ABOUT WASTE OF ELECTRICAL AND ELECTRONICS EQUIPMENT.

According to the Directive “RAEE” 2012/19/UE if the component / equipment purchased is marked with the following crossed-out wheeled bin symbol, it means that the product at the end of its useful life must be collected separately from other waste. The separate collection of this equipment / component at the end of its life is organized and managed by the manufacturer. The user who wants to get rid of this equipment must therefore contact the manufacturer and follow the system that this has adopted to allow the separate collection of the equipment at the end of its life. recycling, treatment and environmentally compatible disposal contributes to avoiding possible negative effects on the environment and health and favors the reuse and / or recycling of the materials of which the equipment is made.

Palazzani

INDUSTRIE

!	<p>WARNING THE ILLEGAL DISPOSAL OF THE PRODUCT BY THE HOLDER LEADS TO THE APPLICATION OF THE ADMINISTRATIVE SANCTIONS PROVIDED FOR BY THE REGULATIONS IN FORCE.</p>
----------	--

!	<p>WARNING IF THE SYMBOL OF THE BARRED BIN IS NOT PRESENT ON THE EQUIPMENT, IT MEANS THAT THE DISPOSAL OF THE PRODUCT ITSELF IS NOT THE MANUFACTURER'S RESPONSIBILITY. IN THIS CASE THE REGULATIONS IN FORCE ON THE DISPOSAL OF WASTE ALWAYS APPLY.</p>
----------	--

6.2.3. DEMOLITION

The machine is built with materials that do not present, for the effects of demolition, particular safety aspects towards humans, more precisely:

- Steel: all the machine parts like boom, supports, base, structure ecc..
- Plastic: lamps and button bodies, tracks / wheels and other electrical components.
- Glass: display and lamps.
- Copper: cables and boards.
- Lead / acid batteries for the starting or for travelling.

According to the CE directives or according to the laws in force in their country, the user must take care of the disposal and elimination of the materials making up the machine for the conservation and protection of the environment. Before demolishing the machine, the user must communicate all the data shown on the identification plate to the manufacturer.

For scrapping the machine or parts of it, you should take all safety precautions necessary to avoid the risks associated with decommissioning.

In particular, special precautions should be taken during the steps of:

- Transport and handling.
- Dismantling.
- Separation of materials.

For the operations of separation of materials and their recycling or their disposal, it is necessary to refer to the National and Regional Laws regarding the disposal of solid industrial waste and dangerous substances.

Palazzani

INDUSTRIE

After having disassembled the machine according to the instructions provided, it is necessary to divide the various materials in accordance with the provisions of the legislation of the country in which the machine must be disposed of.

The operations described below are permitted only to personnel qualified for this purpose and authorized:

- create sufficient space around the machine to perform all movements without risk to personnel
- if necessary, disconnect the power supply cable from the disconnecting device, first disconnecting the power conductors and then the ground conductor
- Only after all the above activities have been carried out, proceed to disassemble the machine proceeding from top to bottom and paying particular attention to the groups / machine parts subject to falling due to gravity and to all parts where product residue may be present.
- For disassembly of parts to trade (machines and / or units) that are part of the machine provided by Palazzani Industries refer to the manufacturer's manual .

After dismantling the machine according to the previous procedure, all the various materials must be segregated with the prescribed rules of the country where the machine must be eliminated.

- remove the mobile parts and separate the various components by type of materials. Separate the parts by type of material that must be recycled (plastic, metal etc..). Entrust the disposal of material obtained from demolishing the companies responsible
- remove and handle the various parts of the machine from work by taking all necessary precautions
- before lifting large parts, check the correct fastening of the lifting devices and use only suitable slings and equipment.



DANGER

The possible loss of parts of components during removal way be a serious danger for operators.



HAZARDOUS SUBSTANCES

The disposal of hazardous waste must be made in compliance with National and Regionals laws giving waste to disposal sites belonging to the Consortium authorized waste oil disposal.

Palazzani

INDUSTRIE



Disposal Electrical and Electronic Equipment (RAEE) under the ROHS Directive.

The electrical and electronic equipment (RAEE) showing this symbol must be recycled.

If the used materials, lubricants and water condensation are not disposed of according to the laws and regulations, there may be residual risks such as:

- environmental pollution
- intoxication of the people responsible for disposal.



OPERATING NOTE

For further questions about the procedure of the machine demolition or topics not covered in this document, contact the manufacturer.

The machine contains about 0.05% by weight of non-recyclable material.

6.3. CONTROL REGISTER

This control register is released by PALAZZANI INDUSTRIE S.p.A. to the user of the Ragno mentioned on the cover, in accordance with Annex I della Direttiva 2006/42 CE.

6.3.1. Storage instructions

This register must be considered like a part of the Operation Manual and it must be with the machine for all its life, till the final disposal.

6.3.2. Instructions for filling

These instructions are provided in accordance with the regulations known before the marketing date of this Ragno. New regulations could be intervene to change the obligations of the user.

The register is designed to record, according to the proposed schemes, the following events concerning the useful life of the aforementioned Ragno:

- property transfer
- replacement of engine, gears, structural elements, safety devices and components
- damage of a certain entity and related repairs
- scheduled maintenance in Chapter 5 of this User and Maintenance Manual



Palazzani

INDUSTRIE

DELIVERY OF RAGNO TO THE FIRST OWNER

Ragno model serial n°, year of manufacture
has been delivered by Palazzani Industrie S.p.A., on to

.....
.....
according to the contractual conditions established, with the tec functional characteri-
stics specified in the instruction manual compendium contained in this Register.

FOLLOWING CHANGE OF PROPERTY

On the property of Ragno is transferred to:

.....
.....
It is certified that, under this date, technical, dimentional and working characteristics of
the platform are exactly corresponding to the ones described in the operational manual
and that eventual modifications have been written on this register.

The seller

The buyer

.....

.....

FOLLOWING CHANGE OF PROPERTY

On the property of Ragno is transferred to:

.....
.....
It is certified that, under this date, technical, dimentional and working characteristics of
the platform are exactly corresponding to the ones described in the operational manual
and that eventual modifications have been written on this register.

The seller

The buyer

.....

.....



Palazzani

INDUSTRIE

GEARS REPLACEMENT

On:
Element description:

Manufacturer: Supplied by:

Cause of replacement:
.....
.....

Responsible of the replacement

The user

.....

GEARS REPLACEMENT

On:
Element description:

Manufacturer: Supplied by:

Cause of replacement:
.....
.....

Responsible of the replacement

The user

.....



SAFETY DEVICES REPLACEMENT

On:
Element description:
.....
Manufacturer: Supplied by:
Cause of replacement:
.....
.....
.....

Responsible of the replacement

The user

.....

.....

SAFETY DEVICES REPLACEMENT

On:
Element description:
.....
Manufacturer: Supplied by:
Cause of replacement:
.....
.....
.....

Responsible of the replacement

The user

.....

.....



RAGNO XTJ 32

**VERSIONE CINGOLATA – CRAWLER VERSION – VERSION MIT CRAWLER -
EXECUTION SUR CHENILLE - VERSIÓN CON ORUGAS**

***Catalogo parti di ricambio
Spare parts catalogue
Ersatzteilkatalog
Catalogue de pièces détachés
Catálogo de piezas de repuestos***



I	<u>ISTRUZIONI PER ORDINARE</u>		
<p>Per evadere correttamente i vostri ordini, fornite i seguenti dati:</p> <table style="width: 100%; border: none;"> <tr> <td style="width: 50%; vertical-align: top;"> <ul style="list-style-type: none"> - Ragione sociale - Indirizzo - Modo di spedizione </td> <td style="width: 50%; vertical-align: top;"> <ul style="list-style-type: none"> - Modello della macchina e numero di matricola - Codice del pezzo - Quantità dei pezzi </td> </tr> </table>		<ul style="list-style-type: none"> - Ragione sociale - Indirizzo - Modo di spedizione 	<ul style="list-style-type: none"> - Modello della macchina e numero di matricola - Codice del pezzo - Quantità dei pezzi
<ul style="list-style-type: none"> - Ragione sociale - Indirizzo - Modo di spedizione 	<ul style="list-style-type: none"> - Modello della macchina e numero di matricola - Codice del pezzo - Quantità dei pezzi 		
GB	<u>INSTRUCTIONS FOR ORDERING</u>		
<p>To ensure your order is processed correctly, please supply all the following information:</p> <table style="width: 100%; border: none;"> <tr> <td style="width: 50%; vertical-align: top;"> <ul style="list-style-type: none"> - Name of company - Address - Preferred method of despatch </td> <td style="width: 50%; vertical-align: top;"> <ul style="list-style-type: none"> - Model of machine and serial number - Part number - Quantity of parts </td> </tr> </table>		<ul style="list-style-type: none"> - Name of company - Address - Preferred method of despatch 	<ul style="list-style-type: none"> - Model of machine and serial number - Part number - Quantity of parts
<ul style="list-style-type: none"> - Name of company - Address - Preferred method of despatch 	<ul style="list-style-type: none"> - Model of machine and serial number - Part number - Quantity of parts 		
D	<u>ANWEISUNGEN FÜR DIE BESTELLUNG</u>		
<p>Um Ihre Bestellungen richtig abzufassen, alle nachstehenden Angaben aufführen:</p> <table style="width: 100%; border: none;"> <tr> <td style="width: 50%; vertical-align: top;"> <ul style="list-style-type: none"> - Firma - Anschrift - Den Versandtyp </td> <td style="width: 50%; vertical-align: top;"> <ul style="list-style-type: none"> - Maschinentyp und Seriennummer - Die Bestellnummer - Die Anzahl der Teile </td> </tr> </table>		<ul style="list-style-type: none"> - Firma - Anschrift - Den Versandtyp 	<ul style="list-style-type: none"> - Maschinentyp und Seriennummer - Die Bestellnummer - Die Anzahl der Teile
<ul style="list-style-type: none"> - Firma - Anschrift - Den Versandtyp 	<ul style="list-style-type: none"> - Maschinentyp und Seriennummer - Die Bestellnummer - Die Anzahl der Teile 		
F	<u>INSTRUCTIONS POUR LES COMMANDES</u>		
<p>Pour libeller correctement vos commandes, donner toujours les indications qui suivent :</p> <table style="width: 100%; border: none;"> <tr> <td style="width: 50%; vertical-align: top;"> <ul style="list-style-type: none"> - Raison sociale - Adresse - Le mode d'expédition </td> <td style="width: 50%; vertical-align: top;"> <ul style="list-style-type: none"> - Modele - Le code article - La quantité de pièces </td> </tr> </table>		<ul style="list-style-type: none"> - Raison sociale - Adresse - Le mode d'expédition 	<ul style="list-style-type: none"> - Modele - Le code article - La quantité de pièces
<ul style="list-style-type: none"> - Raison sociale - Adresse - Le mode d'expédition 	<ul style="list-style-type: none"> - Modele - Le code article - La quantité de pièces 		
E	<u>INSTRUCCIONES PARA LOS PEDIDOS</u>		
<p>Para redactar correctamente sus pedidos, tendràn que indicar los datos siguientes :</p> <table style="width: 100%; border: none;"> <tr> <td style="width: 50%; vertical-align: top;"> <ul style="list-style-type: none"> - Razòn social - Senas - Modo de expedición </td> <td style="width: 50%; vertical-align: top;"> <ul style="list-style-type: none"> - Modelo de la maquina y número de serie - El código artículo - La cantidad de piezas </td> </tr> </table>		<ul style="list-style-type: none"> - Razòn social - Senas - Modo de expedición 	<ul style="list-style-type: none"> - Modelo de la maquina y número de serie - El código artículo - La cantidad de piezas
<ul style="list-style-type: none"> - Razòn social - Senas - Modo de expedición 	<ul style="list-style-type: none"> - Modelo de la maquina y número de serie - El código artículo - La cantidad de piezas 		



TELAIO
CHASSIS
CHASSIS
CHASSIS
CHASIS

TAV. 01

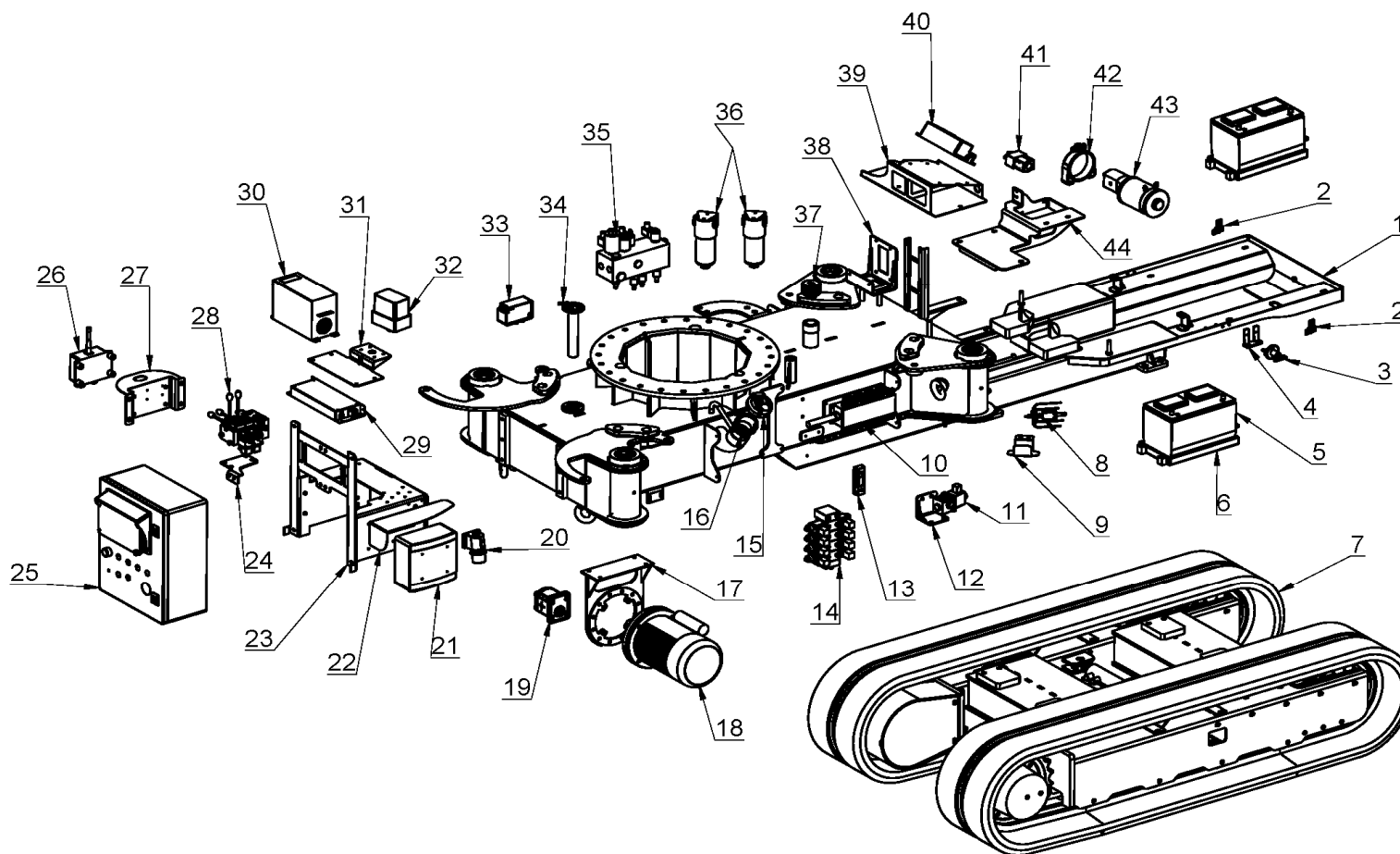



RIF	CODICE	N°	DESCRIZIONE	DESCRIPTION	BENNENNUNG	DESIGNATION	DENOMINACIONES	ANNOTAZIONI
1	05.92.0009	1	TELAIO	CHASSIS	CHASSIS	CHASSIS	CHASSIS	
2	13.92.0163	2	STAFFA	SUPPORT	LAGERUNG	SUPPORT	SOSTEN	
3	14.12.0123	1	STACCA BATTERIA	BATTERY SWITCH	BATTERY SWITCH	BATTERY SWITCH	BATTERY SWITCH	
4	08.14.2990	1	STAFFA	SUPPORT	LAGERUNG	SUPPORT	SOSTEN	
5	55.19.0014	2	BATTERIA	BATTERY	BATTERY	BATTERIE	BATERIA	
6	08.14.3136	2	STAFFA	SUPPORT	LAGERUNG	SUPPORT	SOSTEN	
7	55.28.0705D	1	CARRO	CHASSIS	CHASSIS	CHASSIS	CHASSIS	
8	/	4	PROXIMITY	PROXIMITY	PROXIMITY	PROXIMITY	PROXIMITY	
9	13.92.0074	4	CARTER	CRANKCASE	GEHAUSE	CARTER	CARTER	
10	/	1	CASSETTA	BOX	BOX	BOITE	CAJA	
11	/	1	ELETTROVALVOLA	ELECTRIC VALVE	ELECTRIC VALVE	ELECTRIC VALVE	ELECTRIC VALVE	
12	13.92.0081	1	STAFFA	SUPPORT	LAGERUNG	SUPPORT	SOSTEN	
13	55.01.0010	1	LIVELLO	INDICATOR	ANZEIGER	INDICATEUR	INDICATOR	
14	/	1	DISTRIBUTORE	CONTROL VALVE	STEUERVENTIL	DISTRIBUTEUR	DISTRIBUDOR	
15	55.03.0268	1	TAPPO	PLUG	VERSCHL.STOPPEN	BOUCHON	TAPON	
16	55.03.0256	1	GHIERA	WASHER	SCHEIBE	RONDELLE	ARANDELA	
17	08.14.3133	1	STAFFA	SUPPORT	LAGERUNG	SUPPORT	SOSTEN	
18	55.28.0710	1	MOTORE 230V	ENGINE 230V	MOTOR 230V	MOTEUR 230V	MOTOR 230V	
19	/	1	POMPA	PUMP	PUMPE	POMPE	BOMBA	
20	14.12.0370	1	PRESA	BOX	BOX	BOITE	CAJA	
21	14.12.0465	1	CENTRALINO	ELECTRC BOX	BOX	BOITE	CAJA	
22	13.92.0087	1	STAFFA	SUPPORT	LAGERUNG	SUPPORT	SOSTEN	
23	08.14.3130	1	STAFFA	SUPPORT	LAGERUNG	SUPPORT	SOSTEN	
24	13.92.0090	1	STAFFA	SUPPORT	LAGERUNG	SUPPORT	SOSTEN	
25	/	1	QUADRO COMANDI	ELECTRIC BOX	BOX	BOITE	CAJA	
26	/	1	RICEVENTE	BOX	BOX	BOITE	CAJA	
27	13.92.0086	1	STAFFA	SUPPORT	LAGERUNG	SUPPORT	SOSTEN	
28	/	1	DISTRIBUTORE	CONTROL VALVE	STEUERVENTIL	DISTRIBUTEUR	DISTRIBUDOR	
							XTJ 32	TAV. 01

TELAIO
CHASSIS
CHASSIS
CHASSIS
CHASSIS

TAV. 01

 XTJ 32

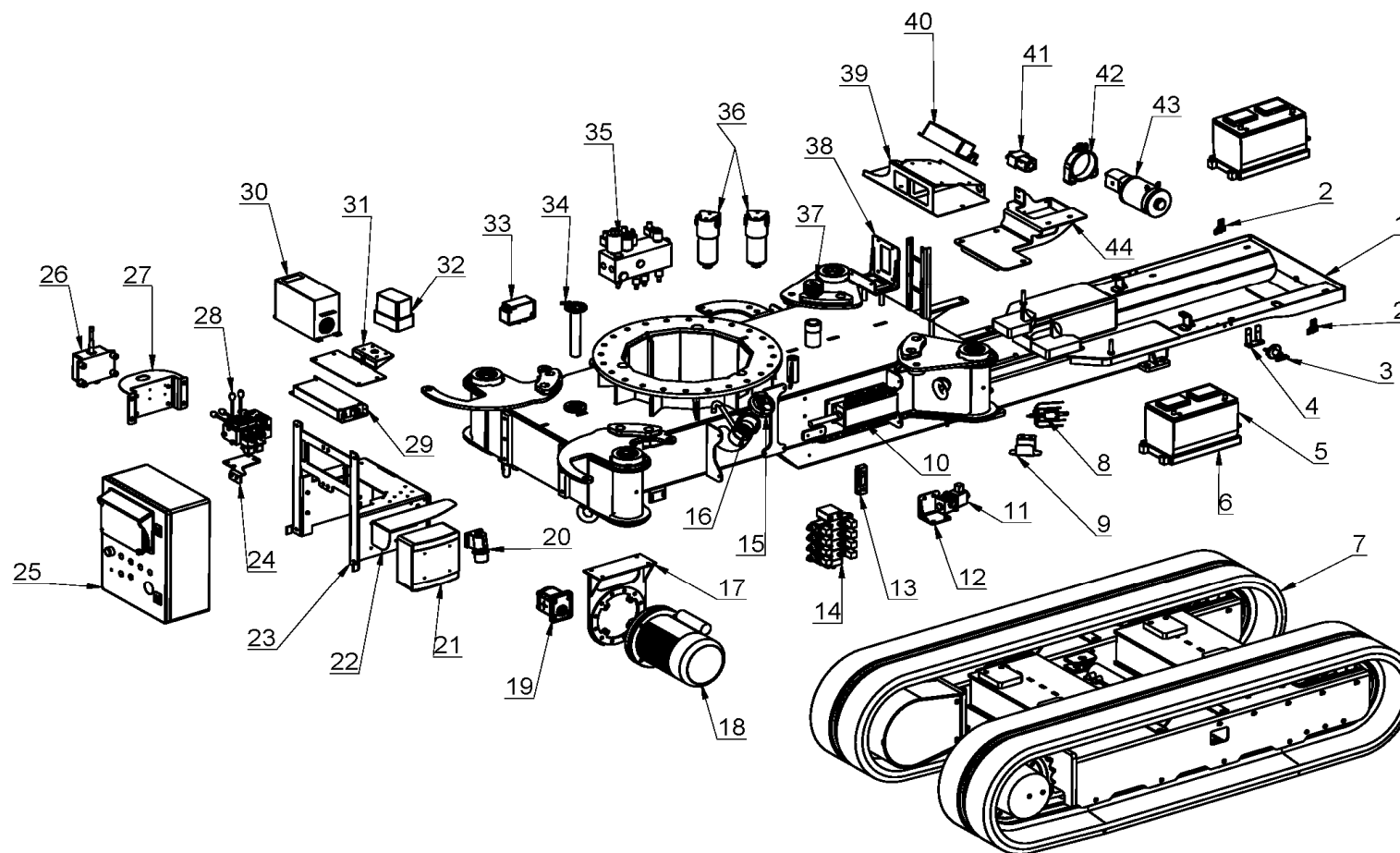



RIF	CODICE	N°	DESCRIZIONE	DESCRIPTION	BENNENNUNG	DESIGNATION	DENOMINACIONES	ANNOTAZIONI
29	14.12.2050	1	FILTRO INVERTER	INVERTER FILTER	INVERTER FILTER	INVERTER FILTER	INVERTER FILTER	
30	14.12.1152B	1	INVERTER	BOX	BOX	BOITE	CAJA	
31	13.92.0169	1	STAFFA	SUPPORT	LAGERUNG	SUPPORT	SOSTEN	
32	/	1	CASSETTA MOTORE	ELECTRIC BOX	BOX	BOITE	CAJA	
33	14.12.2004	1	SENSORE ANGOL.	ANGLE SENSOR	ANGLE SENSOR	ANGLE SENSOR	ANGLE SENSOR	
34	14.12.0800	1	GALLEGGIANTE	INDICATOR	ANZEIGER	INDICATEUR	INDICATOR	
35	/	1	DISTRIBUTORE	CONTROL VALVE	STEUERVENTIL	DISTRIBUTEUR	DISTRIBUDOR	
36	50.12.0261	2	FILTRO	FILTER	FILTER	FILTRE	FILTRO	
37	55.03.0380	1	TAPPO	PLUG	VERSCHL.STOPPEN	BOUCHON	TAPON	
38	13.92.0162	1	STAFFA	SUPPORT	LAGERUNG	SUPPORT	SOSTEN	
39	13.92.0164	1	STAFFA	SUPPORT	LAGERUNG	SUPPORT	SOSTEN	
40	55.28.0612	1	CARICA BATTERIA	BATTERY CHARGER	BATTERY CHARGER	BATTERY CHARGER	BATTERY CHARGER	
41	/	1	TELERUTTORE	TELERUCTOR	TELERUCTOR	TELERUCTOR	TELERUCTOR	
42	55.28.0014A	1	STAFFA	SUPPORT	LAGERUNG	SUPPORT	SOSTEN	
43	55.28.0014	1	ELETTRO POMPA	ELECTRO PUMP	ELECTRO PUMP	ELECTRO PUMP	ELECTRO PUMP	
44	13.92.0102	1	STAFFA	SUPPORT	LAGERUNG	SUPPORT	SOSTEN	
							XTJ 32	TAV. 01

MOTORE DIESEL
DIESEL ENGINE
MOTOR
MOTEUR
MOTOR

TAV. 02

 XTJ 32

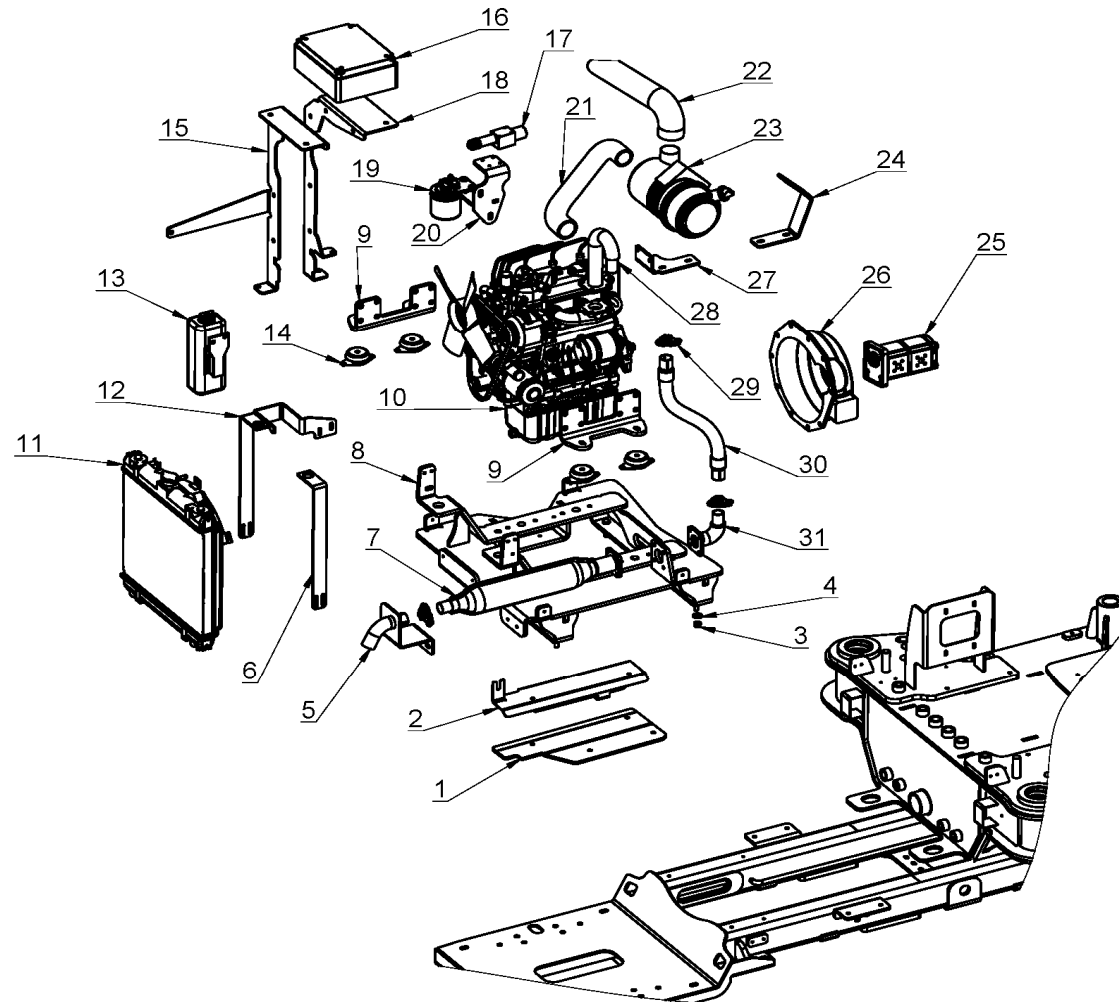



RIF	CODICE	N°	DESCRIZIONE	DESCRIPTION	BENNENNUNG	DESIGNATION	DENOMINACIONES	ANNOTAZIONI
1	55.01.0227	1	RIVESTIMENTO	ROOF	VERKLEIDUNG UNTERDACH	PROTECTION	CUBIERTA	
2	13.126.0045	1	STAFFA	SUPPORT	LAGERUNG	SUPPORT	SOSTEN	
3	55.11.0004	4	RONDELLA	WASHER	UNTERLEGSCHIEBE	RONDELLE	ARANDELA	
4	19.02.0024	4	DADO	NUT	MUTTER	ECROU	TUERCA	
5	13.126.0046	1	STAFFA	SUPPORT	LAGERUNG	SUPPORT	SOSTEN	
6	13.126.0057	1	STAFFA	SUPPORT	LAGERUNG	SUPPORT	SOSTEN	
7	/	1	SILENZIATORE	SILENCER	SCHALLDAEMPFER	SILENCIEUX	SILENCIADOR	
8	05.133.0007	1	SUPPORTO	SUPPORT	LAGERUNG	SUPPORT	SOSTEN	
9	05.126.0043	2	STAFFA	SUPPORT	LAGERUNG	SUPPORT	SOSTEN	
10	55.28.0871	1	MOTORE	ENGINE	ENGINE	MOTEUR	MOTOR	
11	/	1	RADIATORE	RADIATOR	KUEHLER	RADIATEUR	RADIADOR	
12	13.126.0058	1	STAFFA	SUPPORT	LAGERUNG	SUPPORT	SOSTEN	
13	/	1	SERBATOIO ACQUA	WATER TANK	WASSERTANK	RESERVOIR D'EAU	TANQUE DE AGUA	
14	55.01.0046	4	ANTIVIBRANTE MOT.	SOCK ABSORBER	SCHWINGUNGSDAMPFER	ANTIVIBRANT	AMORTIGUADOR	
15	13.126.0059	1	STAFFA	SUPPORT	LAGERUNG	SUPPORT	SOSTEN	
16	/	1	CASSETTA	BOX	BOX	BOITE	CAJA	
17	/	1	PISTONE ELETT.	ELECTRIC PISTON	ELECTRIC PISTON	ELECTRIC PISTON	ELECTRIC PISTON	
18	13.126.0060	1	STAFFA	SUPPORT	LAGERUNG	SUPPORT	SOSTEN	
19	/	1	FILTRO GASOLIO	DIESEL FILTER	FILTEREINSATZ	FILTRE	LIMPIADOR	
20	13.126.0044	1	STAFFA	SUPPORT	LAGERUNG	SUPPORT	SOSTEN	
21	/	1	TUBO	PIPE	EISENRHOR	TUYAU	TUBO	
22	55.02.0234	1	TUBO	PIPE	EISENRHOR	TUYAU	TUBO	
23	/	1	FILTRO ARIA	AIR FILTER	LUFTFILTER	FILTRE AIR	FILTRO DE AIRE	
24	13.56.0084	1	STAFFA	SUPPORT	LAGERUNG	SUPPORT	SOSTEN	
25	/	1	POMPA	PUMP	PUMP	POMPE	BOMBA	
26	/	1	FLANGIA	FLANGE	FLANSCH	FLASQUE	PLETINA	
27	13.126.0047	1	STAFFA	SUPPORT	LAGERUNG	SUPPORT	SOSTEN	
28	13.126.0047	1	TUBO	PIPE	EISENRHOR	TUYAU	TUBO	
29	55.28.0620	3	FASCETTA	CLAMP	HALTESCHELLE	COLLIER	ABRAZADERA	
30	08.14.2768	1	TUBO	PIPE	EISENRHOR	TUYAU	TUBO	
31	08.14.2944	1	STAFFA	SUPPORT	LAGERUNG	SUPPORT	SOSTEN	



TORRETTA
TURNTABLE
TURM
TOURELLE
TORRE

TAV. 03

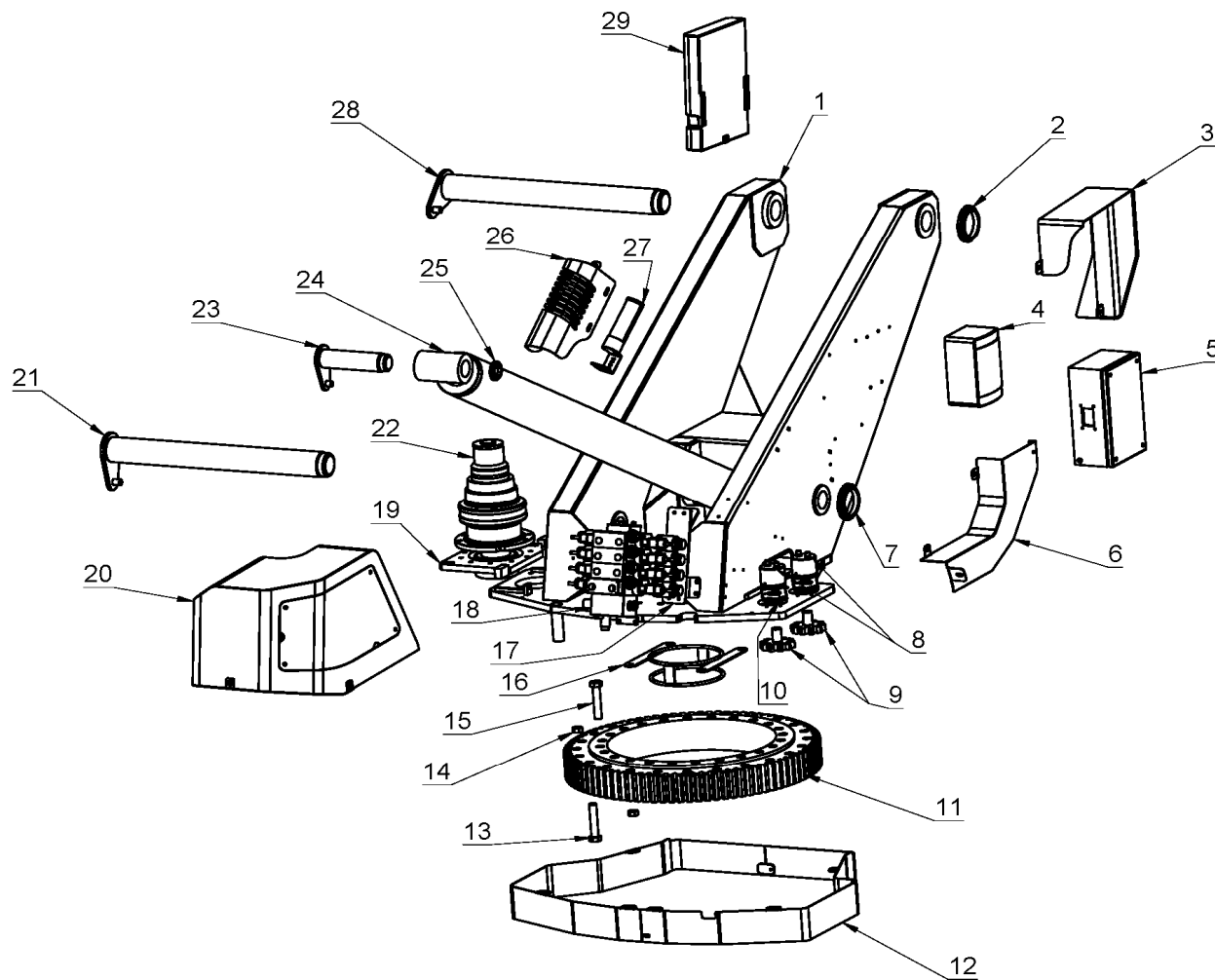



RIF	CODICE	N°	DESCRIZIONE	DESCRIPTION	BENNENNUNG	DESIGNATION	DENOMINACIONES	ANNOTAZIONI
1	05.14.1763	1	TORRETTA	TURNTABLE	TURM	TOURELLE	TORRE	
2	50.09.0062	1	GHIERA	WASHER	SCHEIBE	RONDELLE	ARANDELA	
3	13.92.0155	1	CARTER	CRANKCASE	GEHAUSE	CARTER	CARTER	
4	/	1	CASSETTA RELE'	BOX	BOX	BOITE	CAJA	
5	/	1	CASSETTA TORRETTA	BOX	BOX	BOITE	CAJA	
6	13.92.0085	1	CARTER	CRANKCASE	GEHAUSE	CARTER	CARTER	
7	50.09.0084	1	GHIERA	WASHER	SCHEIBE	RONDELLE	ARANDELA	
8	/	2	ENCODER	BOX	BOX	BOITE	CAJA	
9	13.103.0141	2	INGRANAGGIO	GEAR	FAGGERATE	ENGRANAGES	ARTES	
10	13.80.0032	2	STAFFA	SUPPORT	LAGERUNG	SUPPORT	SOSTEN	
11	55.28.0352	1	RALLA	SLEWING REAR RING	SATTELKUPPLUNG	COURONNE DE ROTATION	RUEDA	
12	13.92.0051	1	CARTER	CRANKCASE	GEHAUSE	CARTER	CARTER	
13	19.01.0547	10	VITE	SCREW	SCHRAUBE	VIS	TORNILLO	
14	19.02.0008	48	DADO	NUT	MUTTER	ECROU	TUERCA	
15	19.01.0383	38	VITE	SCREW	SCHRAUBE	VIS	TORNILLO	
16	13.92.0041	1	STAFFA	SUPPORT	LAGERUNG	SUPPORT	SOSTEN	
17	13.92.0040	1	STAFFA	SUPPORT	LAGERUNG	SUPPORT	SOSTEN	
18	/	1	DISTRIBUTORE	CONTROL VALVE	STEUERVENTIL	DISTRIBUTEUR	DISTRIBUDOR	
19	08.14.3059	1	STAFFA	SUPPORT	LAGERUNG	SUPPORT	SOSTEN	
20	13.92.0084	1	CARTER	CRANKCASE	GEHAUSE	CARTER	CARTER	
21	07.14.1135	1	PERNO	PIN	ZAPFEN	GOUPILLE	PASADOR	
22	/	1	RIDUTTORE	MOTOR	MOTOR	MOTEUR	MOTOR	
23	07.14.1133	1	PERNO	PIN	ZAPFEN	GOUPILLE	PASADOR	
24	01.01.0616	1	MARTINETTO	CYLINDER	HUBZYLINDER	VERIN	CILINDRO	
25	50.09.0084	1	GHIERA	WASHER	SCHEIBE	RONDELLE	ARANDELA	
26	13.65.0059		STAFFA	SUPPORT	LAGERUNG	SUPPORT	SOSTEN	
27	/	1	LUCE VERDE	GREEN LIGHT	GREEN LIGHT	GREEN LIGHT	GREEN LIGHT	
28	07.14.1136	1	PERNO	PIN	ZAPFEN	GOUPILLE	PASADOR	
29	55.28.0525	1	PORTA DOCUMENTI	SUPPORT	LAGERUNG	SUPPORT	SOSTEN	



RIF	CODICE	N°	DESCRIZIONE	DESCRIPTION	BENNENNUNG	DESIGNATION	DENOMINACIONES	ANNOTAZIONI
1	07.92.0001	4	PERNO	PIN	ZAPFEN	GOUPILLE	PASADOR	
2	07.14.1140	4	PERNO	PIN	ZAPFEN	GOUPILLE	PASADOR	
3	13.92.0002A	4	STAFFA	SUPPORT	LAGERUNG	SUPPORT	SOSTEN	
4	14.01.0186	4	MOLLA	SPRING	FEDER	RESSORT	MUELLE	
5	13.92.0002B	4	STAFFA	SUPPORT	LAGERUNG	SUPPORT	SOSTEN	
6	13.92.0002C	4	STAFFA	SUPPORT	LAGERUNG	SUPPORT	SOSTEN	
7	19.02.0004	4	DADO	NUT	MUTTER	ECROU	TUERCA	
8	/	4	FINECORSA	PROXIMITY	PROXIMITY	PROXIMITY	PROXIMITY	
9	/	4	FINECORSA	PROXIMITY	PROXIMITY	PROXIMITY	PROXIMITY	
10	13.92.0096	4	STAFFA	SUPPORT	LAGERUNG	SUPPORT	SOSTEN	
11	50.09.0064	4	GHIERA	WASHER	SCHEIBE	RONDELLE	ARANDELA	
12	05.14.1749	4	PUNTONE	BOOM	AUSLAGER	FLECHE	PLUMA	
13	13.92.0058	4	CARTER	CRANKCASE	GEHAUSE	CARTER	CARTER	
14	55.07.0025	8	SEEGER	SEEGER	SEEGER	SEEGER	SEEGER	
15	07.14.1159	4	PERNO	PIN	ZAPFEN	GOUPILLE	PASADOR	
16	50.09.0064	4	GHIERA	WASHER	SCHEIBE	RONDELLE	ARANDELA	
17	05.92.0015	4	SECONDO BRACCIO	2° BOOM	2° AUSLAGER	2° FLECHE	2° PLUMA	
18	50.09.0058	4	GHIERA	WASHER	SCHEIBE	RONDELLE	ARANDELA	
19	05.14.1594	4	PIATTELLO	PLATE	BEFESTIGUNGSSCHEIBE	PLAT	PLATO	
20	07.14.1000	4	PERNO	PIN	ZAPFEN	GOUPILLE	PASADOR	
21	07.14.1157	4	PERNO	PIN	ZAPFEN	GOUPILLE	PASADOR	
22	/	4	FINECORSA	PROXIMITY	PROXIMITY	PROXIMITY	PROXIMITY	
23	08.14.3525	4	STAFFA	SUPPORT	LAGERUNG	SUPPORT	SOSTEN	
24	19.02.0005	4	DADO	NUT	MUTTER	ECROU	TUERCA	
25	13.101.0050	4	STAFFA	SUPPORT	LAGERUNG	SUPPORT	SOSTEN	
26	14.01.0184	4	MOLLA	SPRING	FEDER	RESSORT	MUELLE	
27	08.14.2955B	4	DISTANZIALE	SPACER	ABSTANDSTUECK	ENTRETOISE	SEPARADOR	
28	14.01.0183	4	MOLLA	SPRING	FEDER	RESSORT	MUELLE	
29	08.14.2955	4	STAFFA	SUPPORT	LAGERUNG	SUPPORT	SOSTEN	
30	55.07.0025	8	SEEGER	SEEGER	SEEGER	SEEGER	SEEGER	
							XTJ 32	TAV. 04



STABILIZZATORE
OUTRIGGER
STUTZEN
BEQUILLE
ESTABILIZADOR

TAV. 04

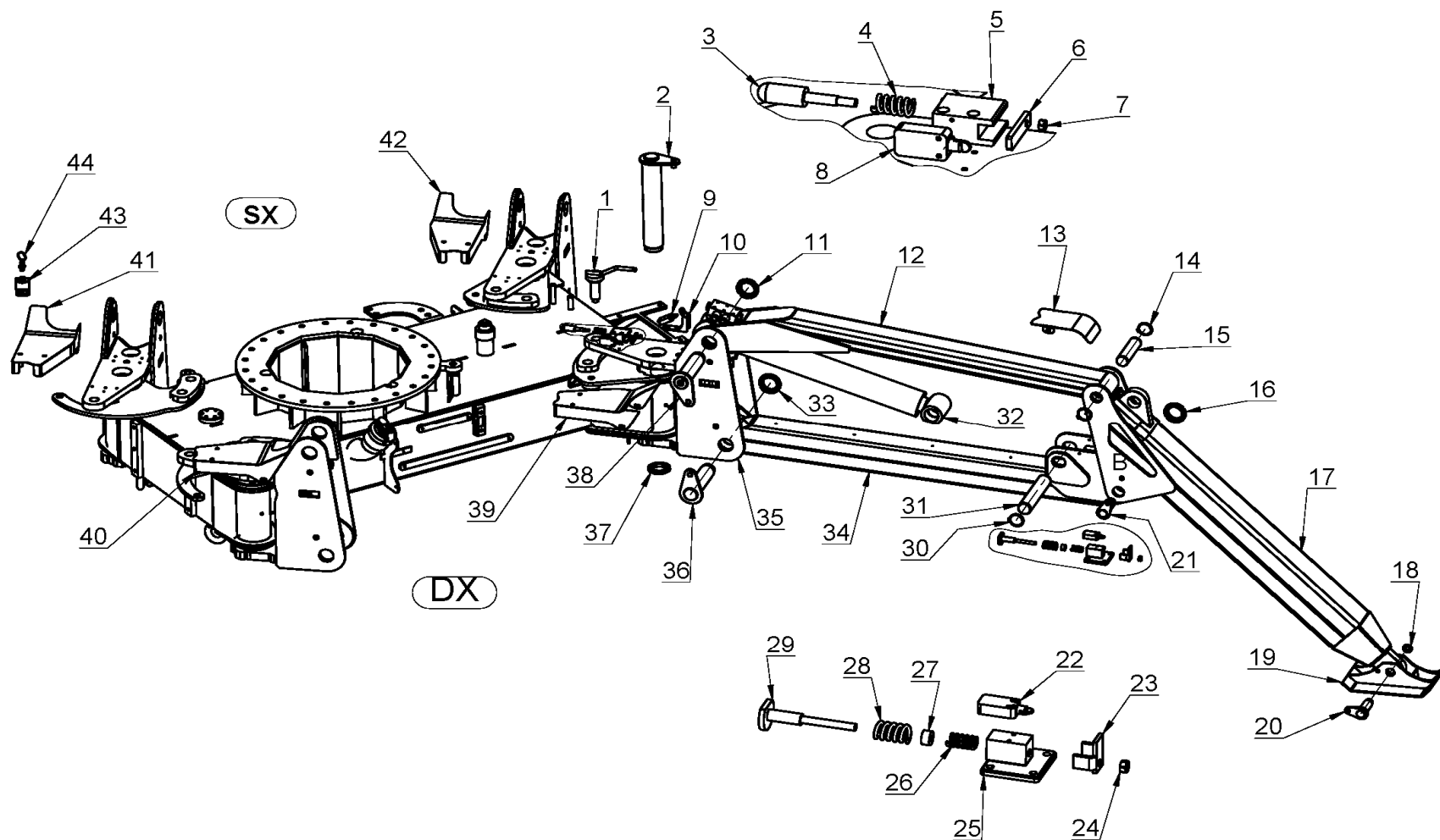



RIF	CODICE	N°	DESCRIZIONE	DESCRIPTION	BENNENNUNG	DESIGNATION	DENOMINACIONES	ANNOTAZIONI
31	07.14.1159	4	PERNO	PIN	ZAPFEN	GOUPILLE	PASADOR	
32	01.01.0618	4	MARTINETTO	CYLINDER	HUBZYLINDER	VERIN	CILINDRO	
33	50.09.0064	4	GHIERA	WASHER	SCHEIBE	RONDELLE	ARANDELA	
34	05.14.1750	4	PRIMO BRACCIO	1° BOOM	1° AUSLAGER	1° FLECHE	1° PLUMA	
35	05.14.1766	4	SUPPORTO STABILIZZATORI	SUPPORT	LAGERUNG	SUPPORT	SOSTEN	
36	07.14.1139	4	PERNO	PIN	ZAPFEN	GOUPILLE	PASADOR	
37	50.09.0083	4	GHIERA	WASHER	SCHEIBE	RONDELLE	ARANDELA	
38	07.14.1138	4	PERNO	PIN	ZAPFEN	GOUPILLE	PASADOR	
39	13.92.0104	1	CARTER	CRANKCASE	GEHAUSE	CARTER	CARTER	
40	13.92.0107	1	CARTER	CRANKCASE	GEHAUSE	CARTER	CARTER	
41	13.92.0106	1	CARTER	CRANKCASE	GEHAUSE	CARTER	CARTER	
42	13.92.0105	1	CARTER	CRANKCASE	GEHAUSE	CARTER	CARTER	
43	13.92.0166	4	STAFFA	SUPPORT	LAGERUNG	SUPPORT	SOSTEN	
44	55.03.0493	4	BLOCCO FERMO	SCREW	SCHRAUBE	VIS	TORNILLO	

CARTER MACCHINA
CARTER MACHINE
CARTER
CARTER
CARTER

TAV. 05

 XTJ 32

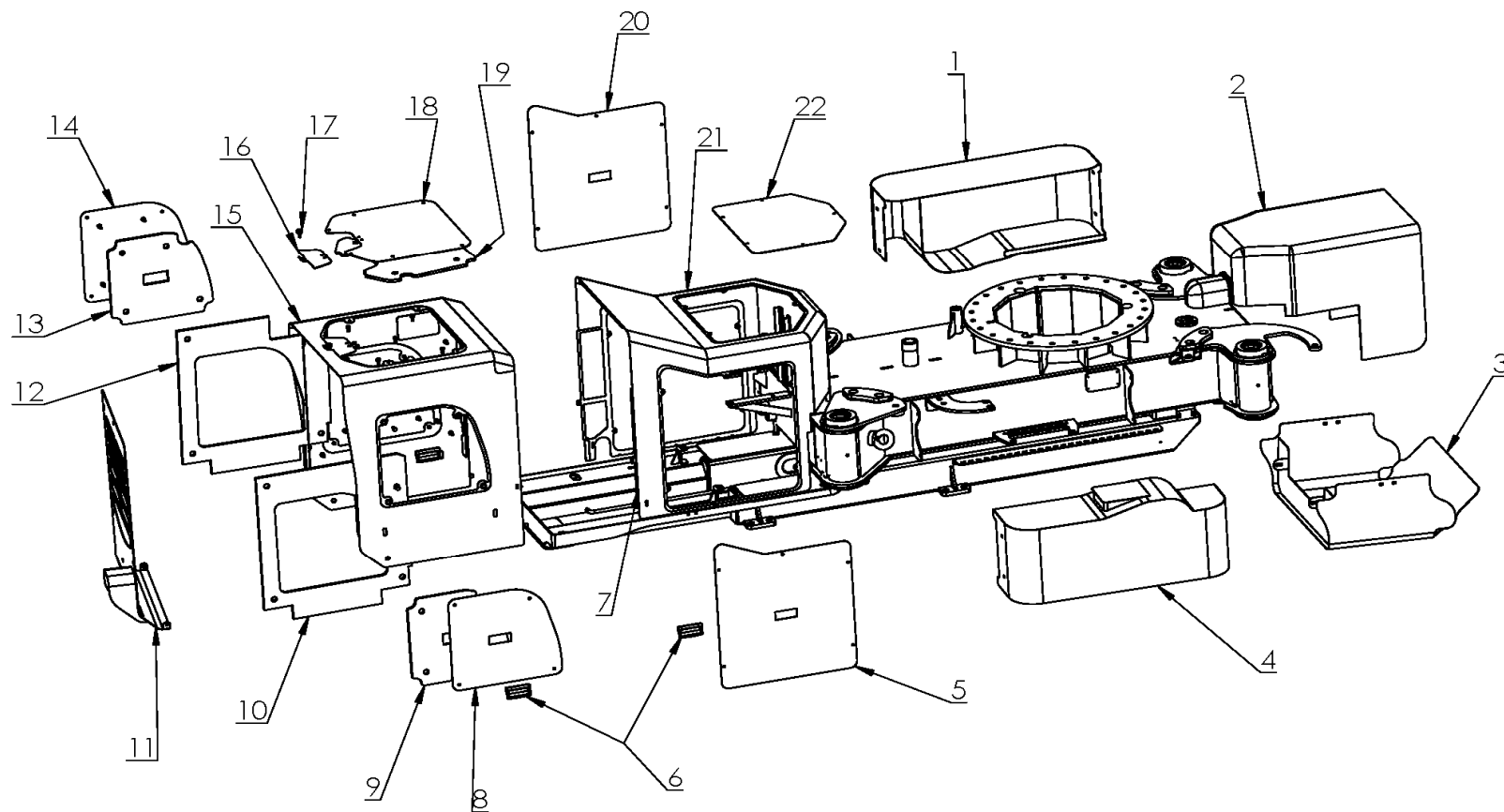



RIF	CODICE	N°	DESCRIZIONE	DESCRIPTION	BENNENNUNG	DESIGNATION	DENOMINACIONES	ANNOTAZIONI
1	13.92.0082	1	CARTER LATERALE	COVERAGE LATERAL	SCHUTZ SIDE	COUVERTURE SIDE	FUNDA LADO	
2	05.14.1873	1	CARTER POSTERIORE	REAR CARTER	REAR CARTER	REAR CARTER	REAR CARTER	
3	13.92.0088	1	CARTER INFERIORE	LOWER COVERAGE	SCHUTZ NIEDER	COUVERT. INEFERIEUR	FUNDA INFERIOR	
4	13.92.0083	1	CARTER LATERALE	COVERAGE LATERAL	SCHUTZ SIDE	COUVERTURE SIDE	FUNDA LADO	
5	05.92.0022_5	1	CARTER LATERALE	COVERAGE LATERAL	SCHUTZ SIDE	COUVERTURE SIDE	FUNDA LADO	
6	55.03.0481	4	MANIGLIA	SCREW	SCHRAUBE	VIS	TORNILLO	
7	05.92.0022	1	CARTER	COVERAGE	SCHUTZ	COUVERTURE	FUNDA	
8	05.133.0005_2	1	CARTER LATERALE	COVERAGE LATERAL	SCHUTZ SIDE	COUVERTURE SIDE	FUNDA LADO	
9	55.01.0226	1	FONO ASSORBENTE	SILENTI ISOLATION	ISOLATION SCHALLDAMPFER	ISOLATION SILENCER	AISLAMIENTO SILENZIOSO	
10	55.01.0225	1	FONO ASSORBENTE	SILENTI ISOLATION	ISOLATION SCHALLDAMPFER	ISOLATION SILENCER	AISLAMIENTO SILENZIOSO	
11	05.133.0008	1	CARTER	COVERAGE	SCHUTZ	COUVERTURE	FUNDA	
12	55.01.0223	1	FONO ASSORBENTE	SILENTI ISOLATION	ISOLATION SCHALLDAMPFER	ISOLATION SILENCER	AISLAMIENTO SILENZIOSO	
13	55.01.0222	1	FONO ASSORBENTE	SILENTI ISOLATION	ISOLATION SCHALLDAMPFER	ISOLATION SILENCER	AISLAMIENTO SILENZIOSO	
14	05.133.0005_7	1	CARTER LATERALE	COVERAGE LATERAL	SCHUTZ SIDE	COUVERTURE SIDE	FUNDA LADO	
15	05.133.0005	1	CARTER	COVERAGE	SCHUTZ	COUVERTURE	FUNDA	
16	05.133.0005_11	1	CARTER	COVERAGE	SCHUTZ	COUVERTURE	FUNDA	
17	55.03.0173	30	POMELLO	SCREW	SCHRAUBE	VIS	TORNILLO	
18	05.133.0005_9	1	CARTER	COVERAGE	SCHUTZ	COUVERTURE	FUNDA	
19	55.01.0224	1	FONO ASSORBENTE	SILENTI ISOLATION	ISOLATION SCHALLDAMPFER	ISOLATION SILENCER	AISLAMIENTO SILENZIOSO	
20	05.92.0022_5	1	CARTER LATERALE	COVERAGE LATERAL	SCHUTZ SIDE	COUVERTURE SIDE	FUNDA LADO	
21	05.92.0022	1	CARTER	COVERAGE	SCHUTZ	COUVERTURE	FUNDA	
22	05.92.0022_8	1	CARTER	COVERAGE	SCHUTZ	COUVERTURE	FUNDA	

CILINDRO SFILO JIB
EXTENSION CYLINDER JIB
VERLÄNGERUNG ZYLINDER JIB
VERIN DE TELESCOPAGE JIB
CILINDRO DE LA EXTENSION JIB

TAV. 06

 **XTJ 32**

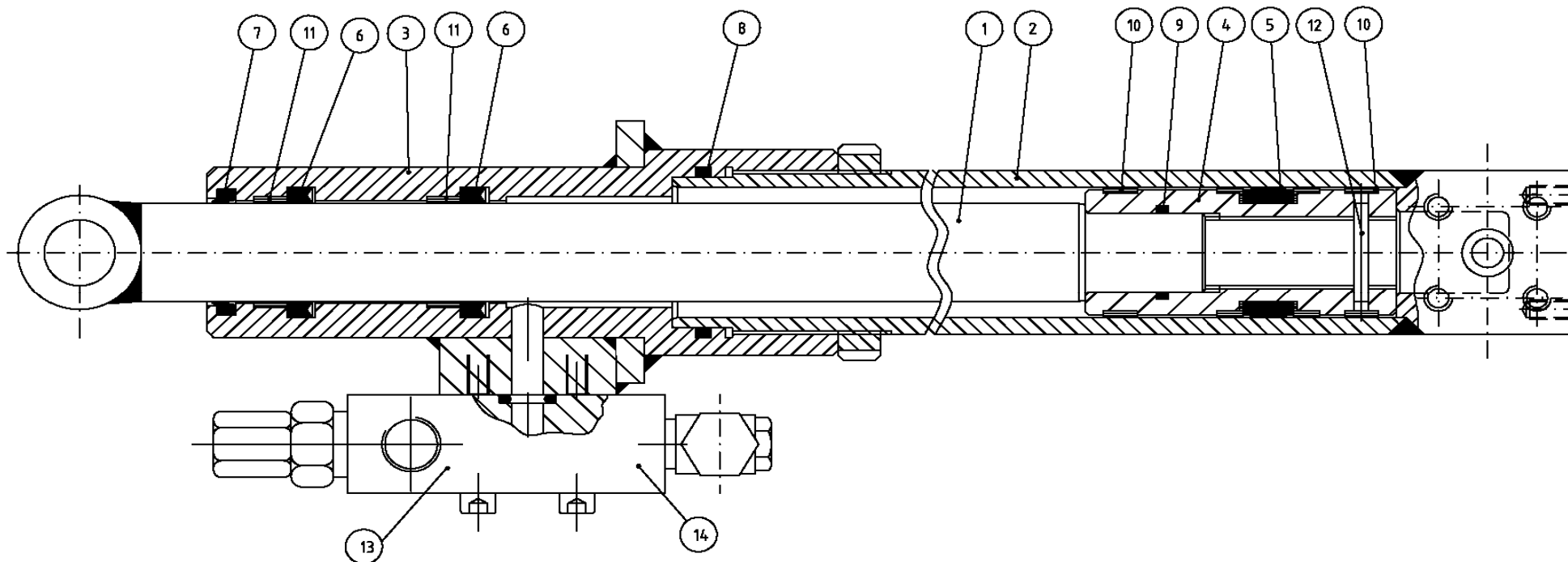



RIF	CODICE	N°	DESCRIZIONE	DESCRIPTION	BENNENNUNG	DESIGNATION	DENOMINACIONES	ANNOTAZIONI
1	01.10.0889	1	STELO	ROD	SHAFT	TIGE	VASTAGO	
2	01.09.0610	1	CAMICIA	CYLINDER LINER	MANTEL	EXTERIEUR DU PISTON	ESTERNO PISTON	
3	01.15.1114	1	TESTATA	BEARING	LAGERBOCK	PALIER	PALIER	
4	01.15.0909	1	STANTUFFO	PISTON	KOLBEN	PISTON	PISTON	
5	18.04.0073	1	GUARNIZIONE	OR JOINT	DICHTUNGSRING	JOINT OR	JUNTA OR	
6	/	2	GUARNIZIONE	OR JOINT	DICHTUNGSRING	JOINT OR	JUNTA OR	
7	18.06.0045	1	RASCHIATORE	SCRATCHER	SCHABEINSEN	RACLEUR	RASPADOR	
8	18.01.0044	1	GUARNIZIONE	OR JOINT	DICHTUNGSRING	JOINT OR	JUNTA OR	
9	18.01.0026	1	GUARNIZIONE	OR JOINT	DICHTUNGSRING	JOINT OR	JUNTA OR	
10	18.05.0055	2	ANELLO DI GUIDA	DRIVING RING	LEITUNGSRING	BAGUE DE GUIDE	ANILLO DE GUIA	
11	/	2	ANELLO DI GUIDA	DRIVING RING	LEITUNGSRING	BAGUE DE GUIDE	ANILLO DE GUIA	
12	55.09.0022	1	SPINA ELASTICA	SCREW	SCHRAUBE	VIS	TORNILLO	
13	/	2	VALVOLA	VALVE	VENTIL	SOUPAPE	VALVULA	
14	19.01.0235	8	VITE	SCREW	SCHRAUBE	VIS	TORNILLO	
15	08.14.2135	1	PATTINO	SLIDING BLOCK	GLEITENDER BLOCK	COULISSEAU	BLOQUE QUE RESBALA	
-	01.01.0615	1	CILINDRO COMPLETO	PISTON	VOLLZYLINDER	PISTON	PISTON	

CILINDRO SOLLEVAMENTO
LIFT CYLINDER
HUBZYLINDER
VERIN DE LEVAGE
CILINDRO ELEVACION

TAV. 07

 **XTJ 32**

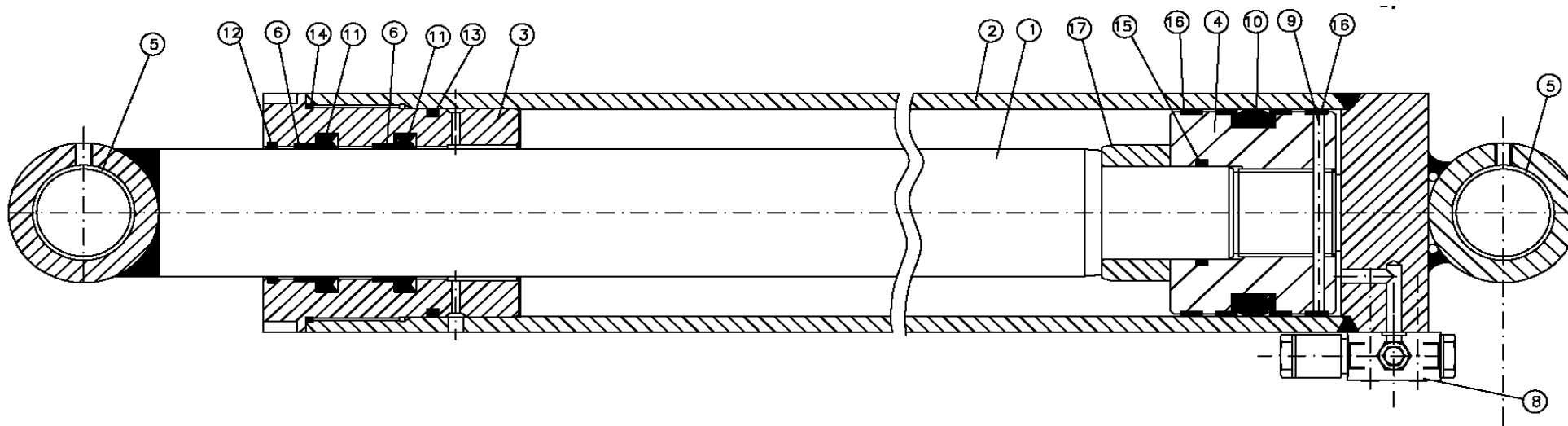



RIF	CODICE	N°	DESCRIZIONE	DESCRIPTION	BENNENNUNG	DESIGNATION	DENOMINACIONES	ANNOTAZIONI
1	01.10.0890	1	STELO	ROD	SHAFT	TIGE	VASTAGO	
2	01.09.0611	1	CAMICIA	CYLINDER LINER	MANTEL	EXTERIEUR DU PISTON	ESTERNO PISTON	
3	01.15.1115	1	BUSSOLA GUIDA	BUSHING	BUCSHE	BAGUE	BUJE	
4	01.15.1116	1	STANTUFFO	PISTON	KOLBEN	PISTON	PISTON	
5	/	4	BUSSOLA	BUSHING	BUCSHE	BAGUE	BUJE	
6	/	2	ANELLO GUIDA	DRIVING RING	LEITUNGSRING	BAGUE DE GUIDE	ANILLO DE GUIA	
7	/	1	VALVOLA	VALVE	VENTIL	SOUPAPE	VALVULA	
8	19.01.0235	4	VITE	SCREW	SCHRAUBE	VIS	TORNILLO	
9	/	1	SPINA ELASTICA	SCREW	SCHRAUBE	VIS	TORNILLO	
10	18.04.0059	1	GUARNIZIONE	OR JOINT	DICHTUNGSRING	JOINT OR	JUNTA OR	
11	/	2	GUARNIZIONE	OR JOINT	DICHTUNGSRING	JOINT OR	JUNTA OR	
12	/	1	RASCHIATORE	SCRATCHER	SCHABEINSEN	RACLEUR	RASPADOR	
13	/	1	GUARNIZIONE	OR JOINT	DICHTUNGSRING	JOINT OR	JUNTA OR	
14	/	1	GUARNIZIONE	OR JOINT	DICHTUNGSRING	JOINT OR	JUNTA OR	
15	/	1	GUARNIZIONE	OR JOINT	DICHTUNGSRING	JOINT OR	JUNTA OR	
16	/	2	ANELLO GUIDA	DRIVING RING	LEITUNGSRING	BAGUE DE GUIDE	ANILLO DE GUIA	
17	01.15.1109	1	BUSSOLA	BUSHING	BUCSHE	BAGUE	BUJE	
-	01.01.0616	1	CILINDRO COMPLETO	PISTON	VOLLZYLINDER	PISTON	PISTON	
							XTJ 32	TAV. 07



CILINDRO SFILO BRACCIO
EXTENSION CYLINDER BOOM
VERLÄNGERUNG ZYLINDER AUSLEGER
VERIN DE TELESCOPAGE FLECHE
CILINDRO DE LA EXTENSION PLUMA

TAV. 08

 **XTJ 32**

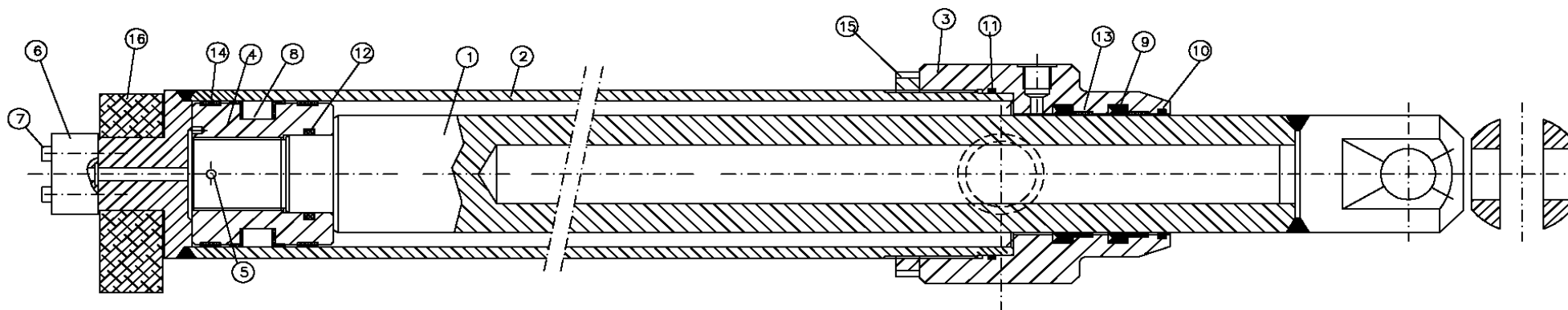



RIF	CODICE	N°	DESCRIZIONE	DESCRIPTION	BENNENNUNG	DESIGNATION	DENOMINACIONES	ANNOTAZIONI
1	01.10.0884	1	STELO	ROD	SHAFT	TIGE	VASTAGO	
2	01.09.0605	1	CAMICIA	CYLINDER LINER	MANTEL	EXTERIEUR DU PISTON	ESTERNO PISTON	
3	01.15.1105	1	BUSSOLA	BUSHING	BUCSHE	BAGUE	BUJE	
4	01.15.1106	1	STANTUFFO	PISTON	KOLBEN	PISTON	PISTON	
5	/	1	SPINA ELASTICA	SCREW	SCHRAUBE	VIS	TORNILLO	
6	/	1	VALVOLA	VALVE	VENTIL	SOUPAPE	VALVULA	
7	19.01.0236	4	VITE	SCREW	SCHRAUBE	VIS	TORNILLO	
8	18.04.0000	1	GUARNIZIONE	OR JOINT	DICHTUNGSRING	JOINT OR	JUNTA OR	
9	/	2	GUARNIZIONE	OR JOINT	DICHTUNGSRING	JOINT OR	JUNTA OR	
10	/	1	RASCHIATORE	SCRATCHER	SCHABEINSEN	RACLEUR	RASPADOR	
11	18.01.0000	1	GUARNIZIONE	OR JOINT	DICHTUNGSRING	JOINT OR	JUNTA OR	
12	/	1	GUARNIZIONE	OR JOINT	DICHTUNGSRING	JOINT OR	JUNTA OR	
13	18.05.0000	2	ANELLO GUIDA	DRIVING RING	LEITUNGSRING	BAGUE DE GUIDE	ANILLO DE GUIA	
14	/	2	ANELLO GUIDA	DRIVING RING	LEITUNGSRING	BAGUE DE GUIDE	ANILLO DE GUIA	
15	01.15.1021	1	GHIERA	WASHER	UNTERLEGSSCHEIBE	RONDELLE	ARANDELA	
16	08.14.3096	1	SUPPORTO	SUPPORT	LAGERUNG	SUPPORT	SOSTEN	
-	01.01.0609	1	CILINDRO COMPLETO	PISTON	VOLLZYLINDER	PISTON	PISTON	
							XTJ 32	TAV. 08



CILINDRO SNODO JIB
CYLINDER JIB
ZYLINDER JIB
VERIN JIB
CILINDRO JIB

TAV. 09



XTJ 32

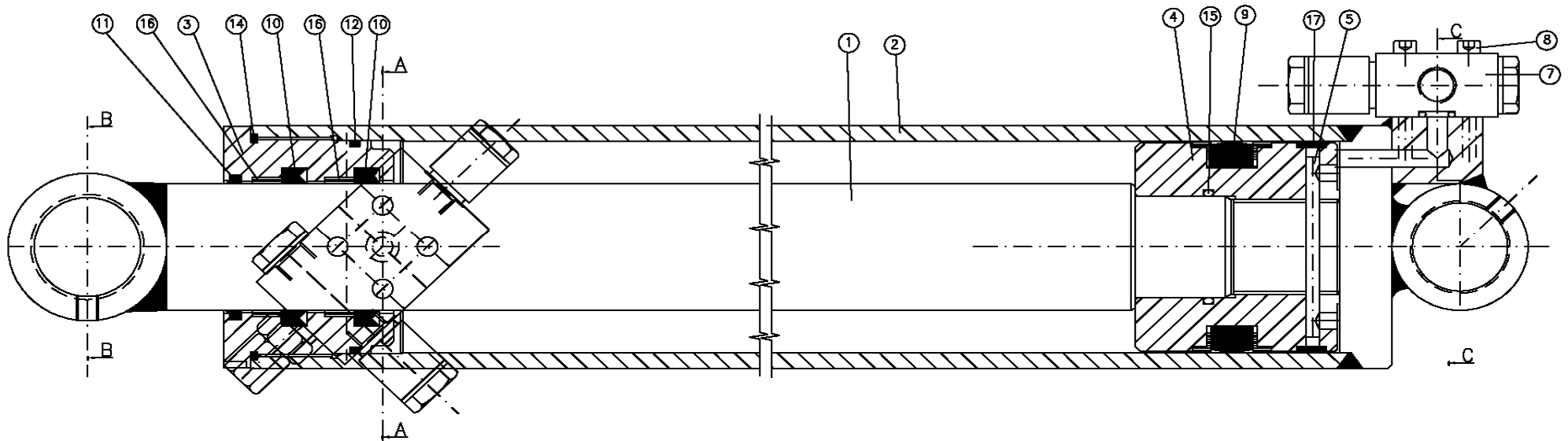



RIF	CODICE	N°	DESCRIZIONE	DESCRIPTION	BENNENNUNG	DESIGNATION	DENOMINACIONES	ANNOTAZIONI
1	01.10.0888	1	STELO	ROD	SHAFT	TIGE	VASTAGO	
2	01.09.0773	1	CAMICIA	CYLINDER LINER	MANTEL	EXTERIEUR DU PISTON	ESTERNO PISTON	
3	01.15.1112	1	BUSSOLA	BUSHING	BUCSHE	BAGUE	BUJE	
4	01.15.1113	1	STANTUFFO	PISTON	KOLBEN	PISTON	PISTON	
5	55.09.0000	1	SPINA ELASTICA	SCREW	SCHRAUBE	VIS	TORNILLO	
6	/	2	BOCCOLA	BUSHING	BUCSHE	BAGUE	BUJE	
7	/	2	VALVOLA	VALVE	VENTIL	SOUPAPE	VALVULA	
8	19.01.0000	8	VITE	SCREW	SCHRAUBE	VIS	TORNILLO	
9	18.04.0000	1	GUARNIZIONE	OR JOINT	DICHTUNGSRING	JOINT OR	JUNTA OR	
10	18.05.0000	2	GUARNIZIONE	OR JOINT	DICHTUNGSRING	JOINT OR	JUNTA OR	
11	18.06.0000	1	RASCHIATORE	SCRATCHER	SCHABEINSEN	RACLEUR	RASPADOR	
12	18.01.0000	1	GUARNIZIONE	OR JOINT	DICHTUNGSRING	JOINT OR	JUNTA OR	
13	/	2	BOCCOLA	BUSHING	BUCSHE	BAGUE	BUJE	
14	18.01.0000	1	GUARNIZIONE	OR JOINT	DICHTUNGSRING	JOINT OR	JUNTA OR	
15	18.05.0000	1	GUARNIZIONE	OR JOINT	DICHTUNGSRING	JOINT OR	JUNTA OR	
16	18.05.0000	2	ANELLO GUIDA	DRIVING RING	LEITUNGSRING	BAGUE DE GUIDE	ANILLO DE GUIA	
17	18.05.0000	1	ANELLO GUIDA	DRIVING RING	LEITUNGSRING	BAGUE DE GUIDE	ANILLO DE GUIA	
-	01.01.0831	1	CILINDRO COMPLETO	PISTON	VOLLZYLINDER	PISTON	PISTON	
							XTJ 32	TAV. 09



**CILINDRO STABILIZZATORI
OUTRIGGER CYLINDER
STUTZEN ZYLINDER
VERIN BEQUILLE
CILINDRO ESTABILIZADOR**

TAV. 10

 **XTJ 32**

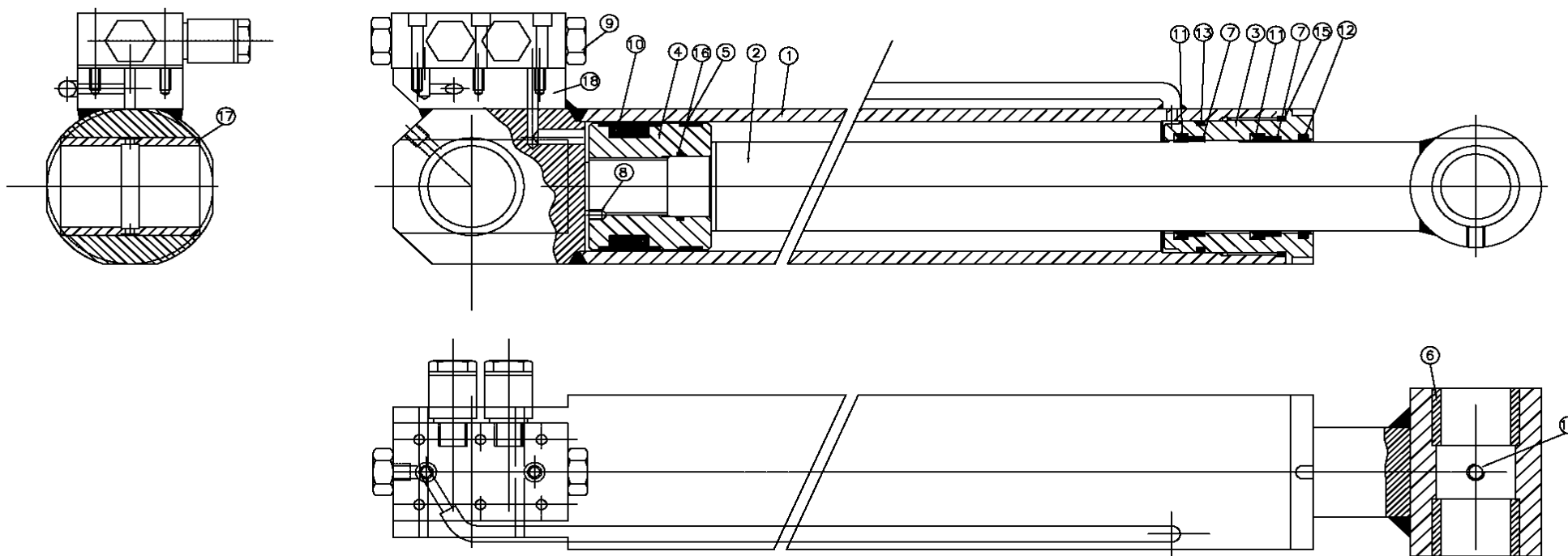



RIF	CODICE	N°	DESCRIZIONE	DESCRIPTION	BENNENNUNG	DESIGNATION	DENOMINACIONES	ANNOTAZIONI
1	01.09.0737	1	CAMICIA	CYLINDER LINER	MANTEL	EXTERIEUR DU PISTON	ESTERNO PISTON	
2	01.10.0892	1	STELO	ROD	SHAFT	TIGE	VASTAGO	
3	01.15.1110	1	FLANGIA ANTERIORE	FLANGE	FLANSCH	FLASQUE	PLETINA	
4	01.15.1104	1	STANTUFFO	PISTON	KOLBEN	PISTON	PISTON	
5	/	1	ANELLO GUIDA	DRIVING RING	LEITUNGSRING	BAGUE DE GUIDE	ANILLO DE GUIA	
6	08.14.2418	2	BUSSOLA	BUSHING	BUCSHE	BAGUE	BUJE	
7	/	2	ANELLO GUIDA	DRIVING RING	LEITUNGSRING	BAGUE DE GUIDE	ANILLO DE GUIA	
8	19.01.0351	1	GRANO DI FERMO	SCREW	SCHRAUBE	VIS	TORNILLO	
9	/	1	VALVOLA	VALVE	VENTIL	SOUPAPE	VALVULA	
10	/	1	GUARNIZIONE	OR JOINT	DICHTUNGSRING	JOINT OR	JUNTA OR	
11	/	2	GUARNIZIONE	OR JOINT	DICHTUNGSRING	JOINT OR	JUNTA OR	
12	/	1	RASCHIATORE	SCRATCHER	SCHABEINSEN	RACLEUR	RASPADOR	
13	/	1	GUARNIZIONE	OR JOINT	DICHTUNGSRING	JOINT OR	JUNTA OR	
14	/	2	INGRASSATORE	GREASE FITTING	FETT-NIPPEL	GRAISSEUR DROIT	ENGRASADOR	
15	/	1	GUARNIZIONE	OR JOINT	DICHTUNGSRING	JOINT OR	JUNTA OR	
16	/	1	GUARNIZIONE	OR JOINT	DICHTUNGSRING	JOINT OR	JUNTA OR	
17	08.14.3104	1	BUSSOLA	BUSHING	BUCSHE	BAGUE	BUJE	
18	08.14.3150	1	BLOCCHETTO VALVOLA	VALVE	VENTIL	SOUPAPE	VALVULA	
-	01.01.0780	1	CILINDRO COMPLETO	PISTON	VOLLZYLINDER	PISTON	PISTON	



GRUPPO BRACCI
GROUP BOOM
GRUPPE AUSLEGER
GROUPE FLECHE
GRUPO PLUMA

TAV. 11



XTJ 32

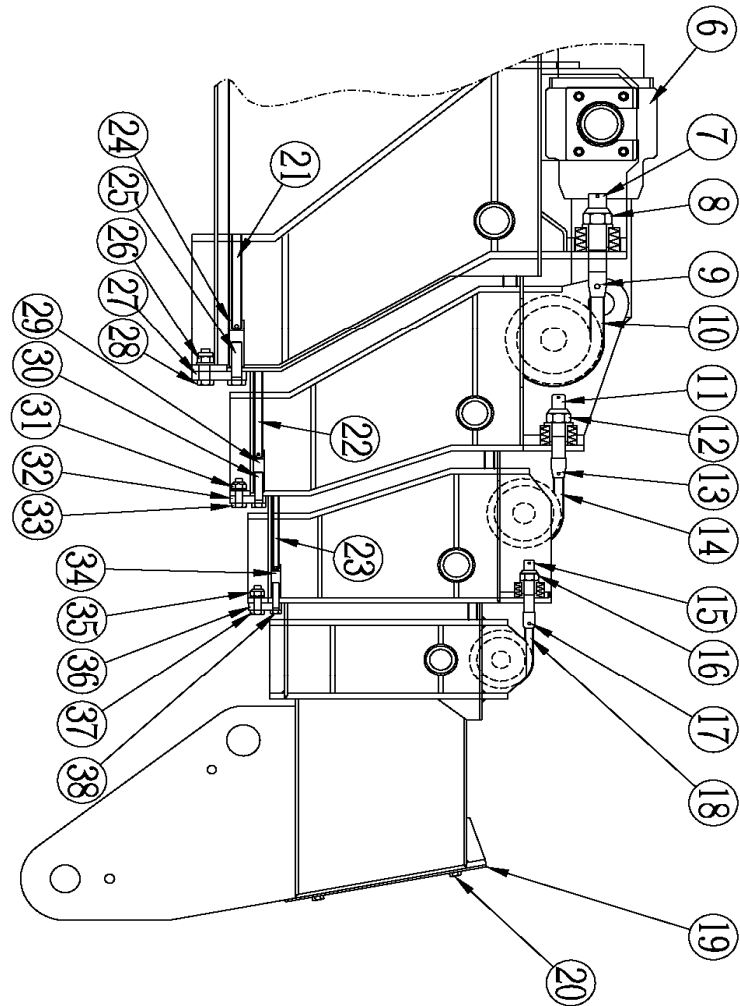
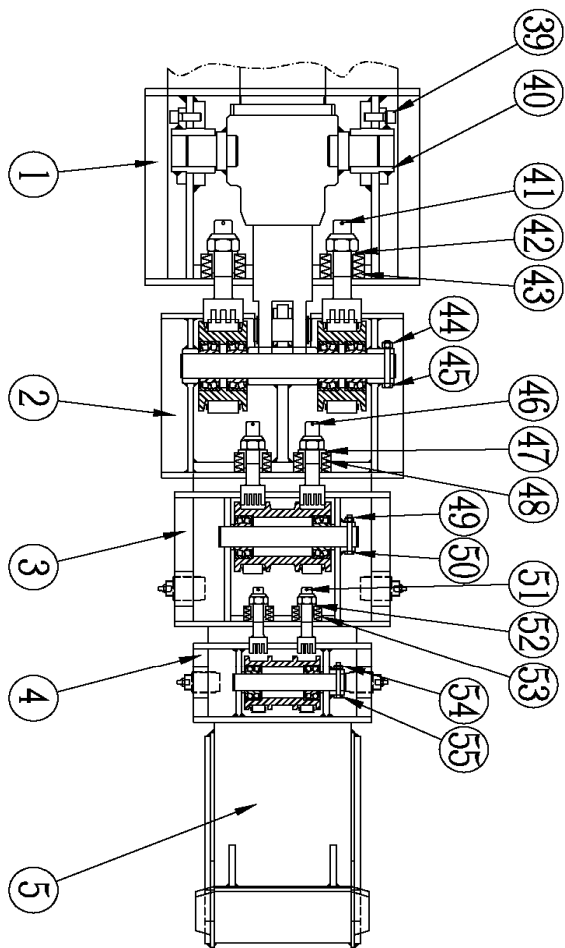



GRUPPO BRACCI
GROUP BOOM
GRUPPE AUSLEGER
GROUPE FLECHE
GRUPO PLUMA

TAV. 11

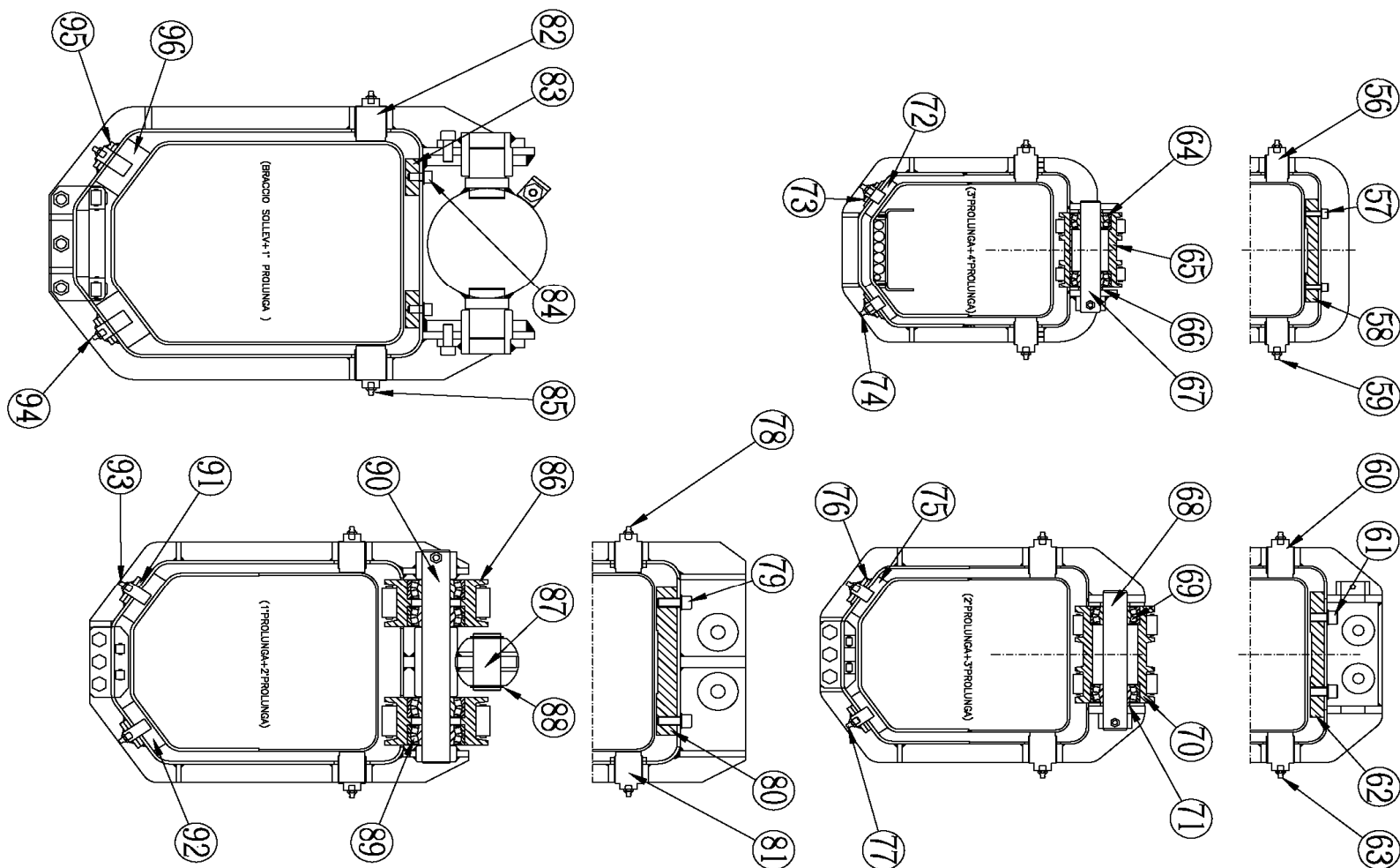



RIF	CODICE	N°	DESCRIZIONE	DESCRIPTION	BENNENNUNG	DESIGNATION	DENOMINACIONES	ANNOTAZIONI
1	05.14.1874	1	BRACCIO SOLLEVAMENTO	LIFTING BOOM	AUSLEGER	BRAS LEVAGE	PLUMA	
2	05.14.1761	1	PRIMA PROLUNGA	1° BOOM	1° AUSLEGER	1° BRAS	1° PLUMA	
3	05.14.1760	1	SECONDA PROLUNGA	2° BOOM	2° AUSLEGER	2° BRAS	2° PLUMA	
4	05.14.1759	1	TERZA PROLUNGA	3° BOOM	3° AUSLEGER	3° BRAS	3° PLUMA	
5	05.14.1758	1	QUARTA PROLUNGA	4° BOOM	4° AUSLEGER	4° BRAS	4° PLUMA	
6	01.01.0609	1	CILINDRO SFILO	EXTENSION RAM	VERLANGERUNG	VERIN DE TELESCOPAGE	CILINDRO EXTENSIONES	
7	08.14.3072	2	TIRANTE CATENA	ROD	PLEUELTANGE	TIRANT	BIELA	
8	19.02.0021	2	DADO	NUT	MUTTER	ECROU	TUERCA	
9	55.28.0592	2	PERNO	PIN	BOLZEN	GOUPILLE	PASADOR	
10	55.28.0545	/	CATENA LH 1266	CHAIN	KETTE	CHAINE	CADENA	
11	08.14.1902	2	TIRANTE CATENA	ROD	PLEUELTANGE	TIRANT	BIELA	
12	19.02.0018	2	DADO	NUT	MUTTER	ECROU	TUERCA	
13	55.28.0098	4	PERNO	PIN	BOLZEN	GOUPILLE	PASADOR	
14	55.28.0046	/	CATENA UF 1588	CHAIN	KETTE	CHAINE	CADENA	
15	08.14.2504	2	TIRANTE CATENA	ROD	PLEUELTANGE	TIRANT	BIELA	
16	19.02.0016	2	DADO	NUT	MUTTER	ECROU	TUERCA	
17	55.28.0571	4	PERNO	PIN	BOLZEN	GOUPILLE	PASADOR	
18	55.28.0563	/	CATENA UF 1266	CHAIN	KETTE	CHAINE	CADENA	
19	08.14.3076	1	COPERCHIO	COVER	DECKEL	COUVERCLE	CUBIERTA	
20	19.01.0003	4	VITE	SCREW	SCHRAUBE	VIS	TORNILLO	
21	55.28.0056	/	CATENA UF 1566	CHAIN	KETTE	CHAINE	CADENA	
22	55.28.0564	/	CATENA UF 1244	CHAIN	KETTE	CHAINE	CADENA	
23	55.28.0050	/	CATENA UF 944	CHAIN	KETTE	CHAINE	CADENA	
24	08.14.3037	1	TIRANTE CATENA	ROD	PLEUELTANGE	TIRANT	BIELA	
25	19.01.0073	2	VITE	SCREW	SCHRAUBE	VIS	TORNILLO	
26	19.02.0025	3	DADO	NUT	MUTTER	ECROU	TUERCA	
27	08.14.3056	1	PIATTO	SUPPORT	LAGERUNG	SUPPORT	SOSTEN	
28	19.01.0053	3	VITE	SCREW	SCHRAUBE	VIS	TORNILLO	
29	08.14.3089	1	TIRANTE	ROD	PLEUELTANGE	TIRANT	BIELA	
30	19.01.0037	2	VITE	SCREW	SCHRAUBE	VIS	TORNILLO	
31	19.02.0024	3	DADO	NUT	MUTTER	ECROU	TUERCA	



RIF	CODICE	N°	DESCRIZIONE	DESCRIPTION	BENNENNUNG	DESIGNATION	DENOMINACIONES	ANNOTAZIONI
32	08.14.1916	1	PIATTO	SUPPORT	LAGERUNG	SUPPORT	SOSTEN	
33	19.01.0035	3	VITE	SCREW	SCHRAUBE	VIS	TORNILLO	
34	08.14.2335	1	TIRANTE	ROD	PLEUELTANGE	TIRANT	BIELA	
35	19.02.0024	3	DADO	NUT	MUTTER	ECROU	TUERCA	
36	08.14.3035	1	PIATTO	SUPPORT	LAGERUNG	SUPPORT	SOSTEN	
37	19.01.0035	3	VITE	SCREW	SCHRAUBE	VIS	TORNILLO	
38	19.01.0266	2	VITE	SCREW	SCHRAUBE	VIS	TORNILLO	
39	19.01.0265	4	VITE	SCREW	SCHRAUBE	VIS	TORNILLO	
40	08.14.3073	2	FLANGIA	BRIDE	FLANSCH	FLANGE	PLETINA	
41	50.10.0021	2	COPIGLIA	SCREW	PLOT	VIS	CENTRAJE	
42	08.14.3082	2	BOCCOLA	BUSH	BUCHSE	DOUILLE	BUJE	
43	55.13.0029	14	MOLLA A TAZZA	WASHER	SCHEIBE	RONDELLE	ARANDELA	
44	19.02.0022	1	DADO	NUT	MUTTER	ECROU	TUERCA	
45	19.01.0012	1	VITE	SCREW	SCHRAUBE	VIS	TORNILLO	
46	55.10.0032	2	COPIGLIA	SCREW	SCHRAUBE	VIS	TORNILLO	
47	08.14.1906	2	BOCCOLA	BUSH	BUCHSE	DOUILLE	BUJE	
48	55.13.0014	14	MOLLA A TAZZA	WASHER	SCHEIBE	RONDELLE	ARANDELA	
49	19.02.0022	1	DADO	NUT	MUTTER	ECROU	TUERCA	
50	19.01.0010	1	VITE	SCREW	SCHRAUBE	VIS	TORNILLO	
51	55.10.0032	2	COPIGLIA	SCREW	SCHRAUBE	VIS	TORNILLO	
52	08.14.2503	2	BOCCOLA	BUSH	BUCHSE	DOUILLE	BUJE	
53	55.13.0030	14	MOLLA A TAZZA	WASHER	SCHEIBE	RONDELLE	ARANDELA	
54	19.02.0022	1	DADO	NUT	MUTTER	ECROU	TUERCA	
55	19.01.0009	1	VITE	SCREW	SCHRAUBE	VIS	TORNILLO	
56	08.14.3030	2	PATTINO	LINING	GLEITENDER BLOCK	GOUJON	TACO	
57	19.01.0239	2	VITE	SCREW	SCHRAUBE	VIS	TORNILLO	
58	08.14.2566	1	PATTINO	LINING	GLEITENDER BLOCK	GOUJON	BLOQUE QUE RESBALA	
59	55.14.0002	2	INGRASSATORE	GREASE FITTING	FETT-NIPPEL	GRAISSEUR	ENGRASADOR	
60	08.14.3034	2	PATTINO	LINING	GLEITENDER BLOCK	GOUJON	TACO	
61	19.01.0264	2	VITE	SCREW	SCHRAUBE	VIS	TORNILLO	
62	08.14.3077	1	PATTINO	LINING	GLEITENDER BLOCK	GOUJON	TACO	
							XTJ 32	TAV. 11



RIF	CODICE	N°	DESCRIZIONE	DESCRIPTION	BENNENNUNG	DESIGNATION	DENOMINACIONES	ANNOTAZIONI
63	55.14.0002	2	INGRASSATORE	GREASE FITTING	FETT-NIPPEL	GRAISSEUR	ENGRASADOR	
64	49.02.0072	2	CUSCINETTO	BALL BEARING	EINGEDENK	ROULEMENT	COJENETE	
65	08.14.3121	1	RULLO	ROLL	ROLLER	ROULEAU	RODILLO	
66	08.14.1911	6	DISTANZIALE	SPACER	ABSTANDSTUECK	ENTRETOISE	SEPARADOR	
67	07.14.0933	1	PERNO	PIN	BOLZEN	GOUPILLE	PASADOR	
68	07.14.0932	1	PERNO	PIN	BOLZEN	GOUPILLE	PASADOR	
69	49.02.0070	2	CUSCINETTO	BALL BEARING	EINGEDENK	ROULEMENT	COJENETE	
70	08.14.3122	1	RULLO	ROLL	ROLLER	ROULEAU	RODILLO	
71	08.14.1910	4	DISTANZIALE	SPACER	ABSTANDSTUECK	ENTRETOISE	SEPARADOR	
72	08.14.3119	2	PATTINO	LINING	GLEITENDER BLOCK	GOUJON	TACO	
73	08.14.2577	2	PIATTO	SUPPORT	LAGERUNG	SUPPORT	SOSTEN	
74	55.14.0005	2	INGRASSATORE	GREASE FITTING	FETT-NIPPEL	GRAISSEUR	ENGRASADOR	
75	08.14.2333	2	PATTINO	LINING	GLEITENDER BLOCK	GOUJON	TACO	
76	08.14.1972	2	PIATTO	SUPPORT	LAGERUNG	SUPPORT	SOSTEN	
77	55.14.0005	2	INGRASSATORE	GREASE FITTING	FETT-NIPPEL	GRAISSEUR	ENGRASADOR	
78	55.14.0002	2	INGRASSATORE	GREASE FITTING	FETT-NIPPEL	GRAISSEUR	ENGRASADOR	
79	19.01.0264	2	VITE	SCREW	SCHRAUBE	VIS	TORNILLO	
80	08.14.3078	1	PATTINO	LINING	GLEITENDER BLOCK	GOUJON	TACO	
81	08.14.3034	4	PATTINO	LINING	GLEITENDER BLOCK	GOUJON	TACO	
82	08.14.3051	2	PATTINO	LINING	GLEITENDER BLOCK	GOUJON	TACO	
83	08.14.3080	2	PATTINO	LINING	GLEITENDER BLOCK	GOUJON	TACO	
84	19.01.0252	4	VITE	SCREW	SCHRAUBE	VIS	TORNILLO	
85	55.14.0002	2	INGRASSATORE	GREASE FITTING	FETT-NIPPEL	GRAISSEUR	ENGRASADOR	
86	08.14.3079	2	RULLO	ROLL	ROLLER	ROULEAU	RODILLO	
87	07.14.1134	1	PERNO	PIN	BOLZEN	GOUPILLE	PASADOR	
88	55.07.0071	2	SEGER	WASHER	UNTERLEGSSCHEIBE	RONDELLE	ARANDELA	
89	49.02.0071	4	CUSCINETTO	BALL BEARING	EINGEDENK	ROULEMENT	COJENETE	
90	07.14.1131	1	PERNO	PIN	BOLZEN	GOUPILLE	PASADOR	
91	08.14.3025	2	PIATTO	SUPPORT	LAGERUNG	SUPPORT	SOSTEN	
92	08.14.3020	2	PIATTO	SUPPORT	LAGERUNG	SUPPORT	SOSTEN	
93	55.14.0005	2	INGRASSATORE	GREASE FITTING	FETT-NIPPEL	GRAISSEUR	ENGRASADOR	
							XTJ 32	TAV. 11



RIF	CODICE	N°	DESCRIZIONE	DESCRIPTION	BENNENNUNG	DESIGNATION	DENOMINACIONES	ANNOTAZIONI
94	55.14.0005	2	INGRASSATORE	GREASE FITTING	FETT-NIPPEL	GRAISSEUR	ENGRASADOR	
95	08.14.1921	2	PIATTO	SUPPORT	LAGERUNG	SUPPORT	SOSTEN	
96	08.14.3081	2	PATTINO	LINING	GLEITENDER BLOCK	GOUJON	TACO	
							XTJ 32	TAV. 11

GRUPPO BRACCI
GROUP BOOM
GRUPPE AUSLEGER
GROUPE FLECHE
GRUPO PLUMA

TAV. 12

 XTJ 32

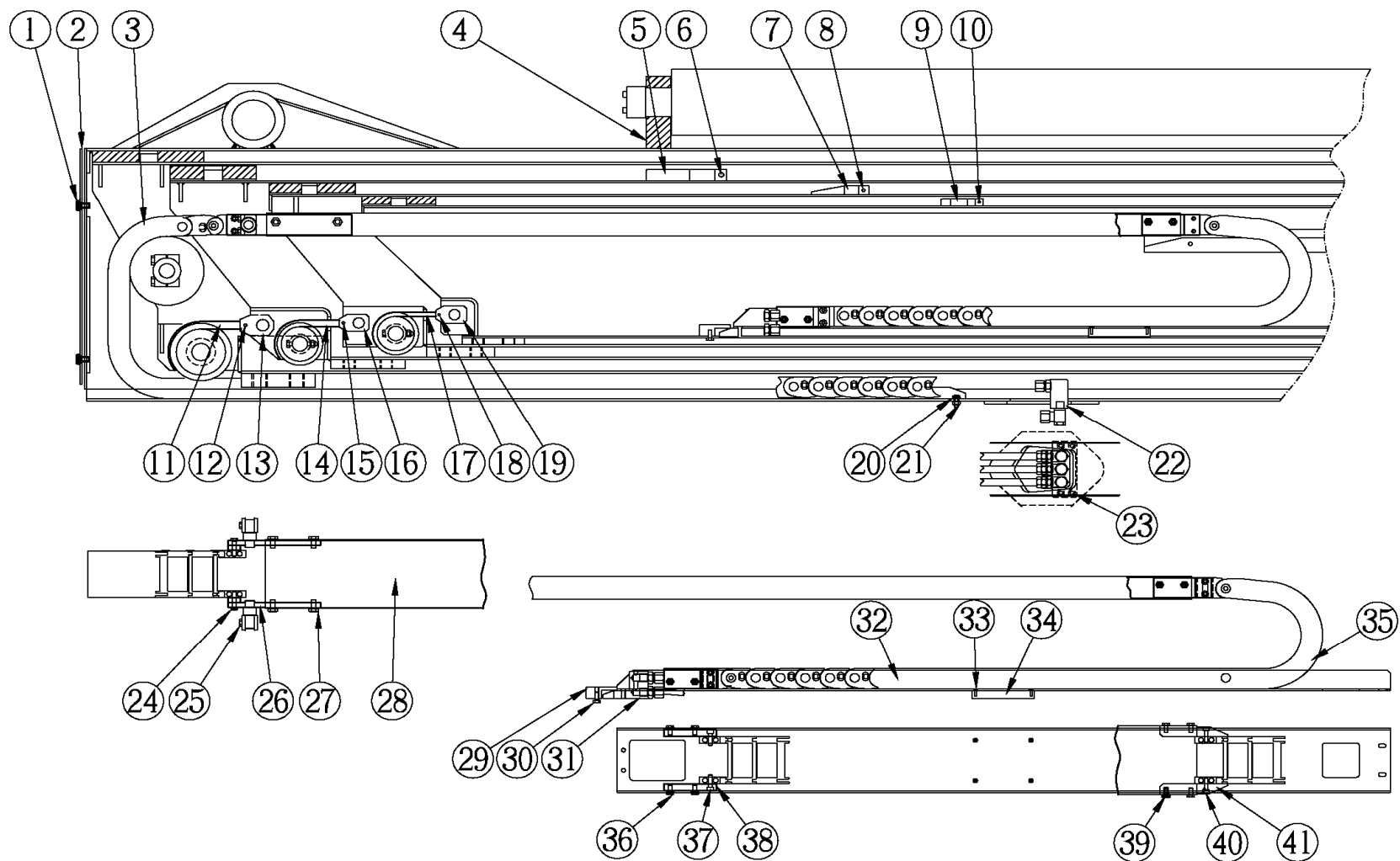



GRUPPO BRACCI
GROUP BOOM
GRUPPE AUSLEGER
GROUPE FLECHE
GRUPO PLUMA

TAV. 12



XTJ 32

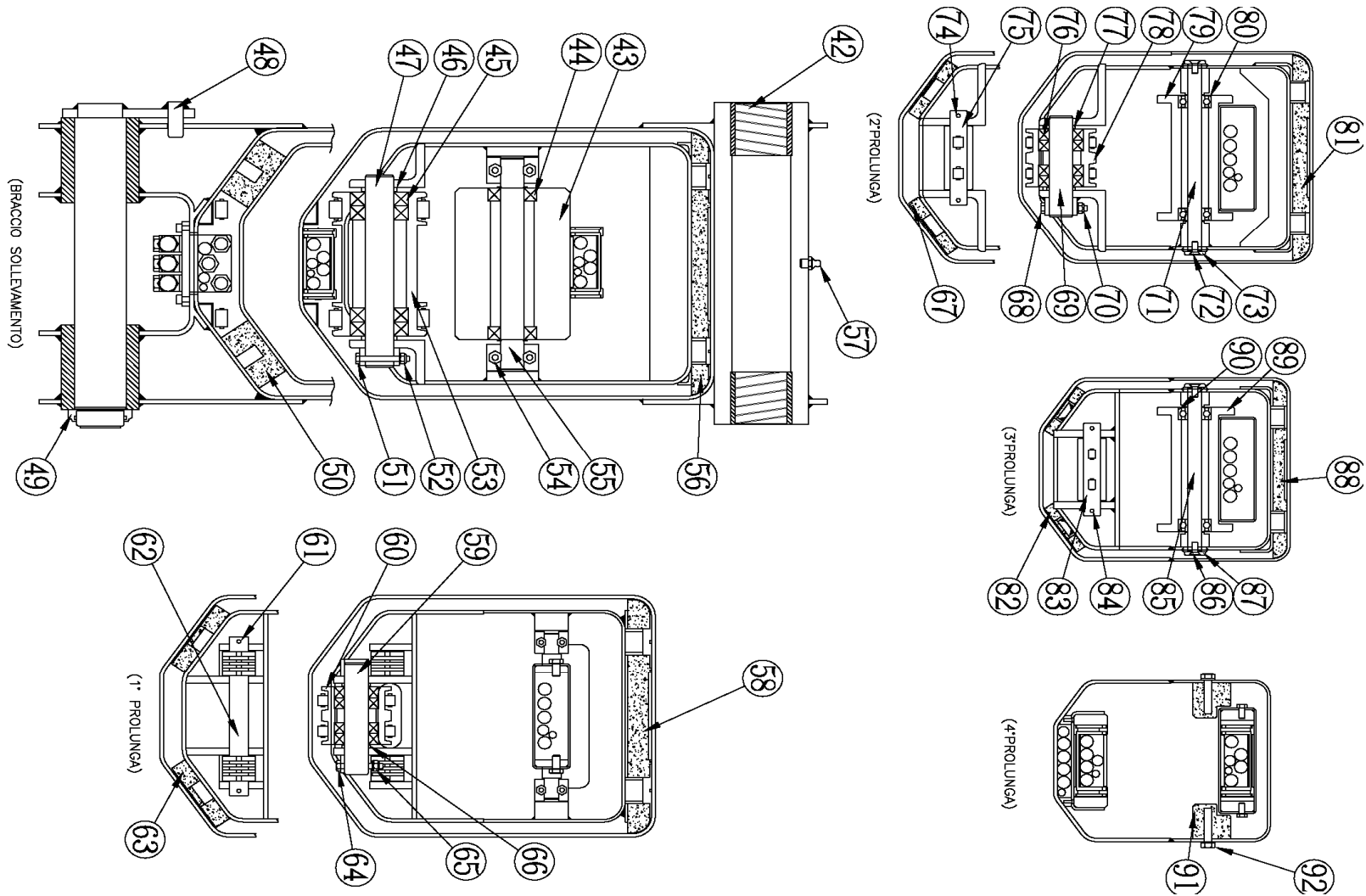



RIF	CODICE	N°	DESCRIZIONE	DESCRIPTION	BENNENNUNG	DESIGNATION	DENOMINACIONES	ANNOTAZIONI
1	19.01.0003	6	VITE	SCREW	SCHRAUBE	VIS	TORNILLO	
2	08.14.3085	1	COPERCHIO	COVER	DECKEL	COUVERCLE	CUBIERTA	
3	55.28.0645	/	CATENARIA	CHAIN	KETTE	CHAINE	CADENA	
4	08.14.3096	1	SUPPORTO	SUPPORT	LAGERUNG	SUPPORT	SOSTEN	
5	08.14.3091	1	TIRANTE	ROD	PLEUELTANGE	TIRANT	BIELA	
6	07.14.1062	2	PERNO	PIN	BOLZEN	GOUPILLE	PASADOR	
7	08.14.3083	1	TIRANTE	ROD	PLEUELTANGE	TIRANT	BIELA	
8	55.28.0098	2	PERNO	PIN	BOLZEN	GOUPILLE	PASADOR	
9	08.14.3123	1	TIRANTE	ROD	PLEUELTANGE	TIRANT	BIELA	
10	55.28.0571	2	PERNO	PIN	BOLZEN	GOUPILLE	PASADOR	
11	55.28.0056	/	CATENA UF 1288	CHAIN	KETTE	CHAINE	CADENA	
12	55.28.0102	2	PERNO	PIN	BOLZEN	GOUPILLE	PASADOR	
13	08.14.3022	2	TIRANTE	ROD	PLEUELTANGE	TIRANT	BIELA	
14	55.28.0564	/	CATENA UF 1288	CHAIN	KETTE	CHAINE	CADENA	
15	55.28.0572	2	PERNO	PIN	BOLZEN	GOUPILLE	PASADOR	
16	08.14.3018	1	TIRANTE	ROD	PLEUELTANGE	TIRANT	BIELA	
17	55.28.0050	2	CATENA UF 1288	CHAIN	KETTE	CHAINE	CADENA	
18	55.28.0100	2	PERNO	PIN	BOLZEN	GOUPILLE	PASADOR	
19	08.14.2321	1	TIRANTE	ROD	PLEUELTANGE	TIRANT	BIELA	
20	19.01.0003	2	VITE	SCREW	SCHRAUBE	VIS	TORNILLO	
21	19.02.0022	2	DADO	NUT	MUTTER	ECROU	TUERCA	
22	08.14.3055	1	MASSELLO	SUPPORT	LAGERUNG	SUPPORT	SOSTEN	
23	19.01.0004	4	VITE	SCREW	SCHRAUBE	VIS	TORNILLO	
24	19.01.0005	4	VITE	SCREW	SCHRAUBE	VIS	TORNILLO	
25	19.01.0004	4	VITE	SCREW	SCHRAUBE	VIS	TORNILLO	
26	08.14.3146	2	STAFFA	SUPPORT	LAGERUNG	SUPPORT	SOSTEN	
27	19.01.0017	4	VITE	SCREW	SCHRAUBE	VIS	TORNILLO	
28	08.14.3095	1	STAFFA	SUPPORT	LAGERUNG	SUPPORT	SOSTEN	
29	08.14.3017	1	STAFFA	SUPPORT	LAGERUNG	SUPPORT	SOSTEN	
30	19.01.0003	2	VITE	SCREW	SCHRAUBE	VIS	TORNILLO	
31	08.14.3047	1	STAFFA	SUPPORT	LAGERUNG	SUPPORT	SOSTEN	
							XTJ 32	TAV. 12



RIF	CODICE	N°	DESCRIZIONE	DESCRIPTION	BENNENNUNG	DESIGNATION	DENOMINACIONES	ANNOTAZIONI
32	08.14.3094	1	STAFFA	SUPPORT	LAGERUNG	SUPPORT	SOSTEN	
33	19.01.0300	12	VITE	SCREW	SCHRAUBE	VIS	TORNILLO	
34	08.14.3046	6	STAFFA	SUPPORT	LAGERUNG	SUPPORT	SOSTEN	
35	55.28.0743	/	CATENARIA	CHAIN	KETTE	CHAINE	CADENA	
36	19.01.0002	4	VITE	SCREW	SCHRAUBE	VIS	TORNILLO	
37	19.01.0231	4	VITE	SCREW	SCHRAUBE	VIS	TORNILLO	
38	08.14.3038	2	STAFFA	SUPPORT	LAGERUNG	SUPPORT	SOSTEN	
39	19.01.0231	4	VITE	SCREW	SCHRAUBE	VIS	TORNILLO	
40	19.01.0231	4	VITE	SCREW	SCHRAUBE	VIS	TORNILLO	
41	08.14.3090	2	STAFFA	SUPPORT	LAGERUNG	SUPPORT	SOSTEN	
42	08.14.2891	2	BOCCOLA	BUSH	BUCHSE	DOUILLE	BUJE	
43	08.14.3043	1	RULLO	ROLL	ROLLER	ROULEAU	RODILLO	
44	49.02.0008	2	CUSCINETTO	BALL BEARING	EINGEDENK	ROULEMENT	COJENETE	
45	49.02.0001	4	CUSCINETTO	BALL BEARING	EINGEDENK	ROULEMENT	COJENETE	
46	13.80.0052	1	STAFFA	SUPPORT	LAGERUNG	SUPPORT	SOSTEN	
47	07.14.1120	1	PERNO	PIN	BOLZEN	GOUPILLE	PASADOR	
48	07.14.1133	1	PERNO	PIN	BOLZEN	GOUPILLE	PASADOR	
49	50.09.0084	1	GHIERA	WASHER	UNTERLEGSSCHEIBE	RONDELLE	ARANDELA	
50	08.14.3088	2	PATTINO	LINING	GLEITENDER BLOCK	GOUJON	TACO	
51	19.01.0010	1	VITE	SCREW	SCHRAUBE	VIS	TORNILLO	
52	19.02.0022	1	DADO	NUT	MUTTER	ECROU	TUERCA	
53	08.14.3023	1	RULLO	ROLL	ROLLER	ROULEAU	RODILLO	
54	19.01.0021	4	VITE	SCREW	SCHRAUBE	VIS	TORNILLO	
55	07.14.1123	1	PERNO	PIN	BOLZEN	GOUPILLE	PASADOR	
56	08.14.3087	1	PATTINO	LINING	GLEITENDER BLOCK	GOUJON	TACO	
57	55.14.0002	1	INGRASSATORE	GREASE FITTING	FETT-NIPPEL	GRAISSEUR	ENGRASADOR	
58	08.14.3090	2	PATTINO	LINING	GLEITENDER BLOCK	GOUJON	TACO	
59	07.14.1021	1	PERNO	PIN	BOLZEN	GOUPILLE	PASADOR	
60	08.14.1183	1	RULLO	ROLL	ROLLER	ROULEAU	RODILLO	
61	55.10.0021	2	COPIGLIA	SCREW	SCHRAUBE	VIS	TORNILLO	
62	07.14.1116	1	PERNO	PIN	BOLZEN	GOUPILLE	PASADOR	
							XTJ 32	TAV. 12



RIF	CODICE	N°	DESCRIZIONE	DESCRIPTION	BENNENNUNG	DESIGNATION	DENOMINACIONES	ANNOTAZIONI
63	08.14.3093	2	PATTINO	LINING	GLEITENDER BLOCK	GOUJON	TACO	
64	19.01.0008	1	VITE	SCREW	SCHRAUBE	VIS	TORNILLO	
65	19.02.0022	1	DADO	NUT	MUTTER	ECROU	TUERCA	
66	08.14.1911	2	DISTANZIALE	SPACER	ABSTANDSTUECK	ENTRETOISE	SEPARADOR	
67	08.14.3019	2	PATTINO	LINING	GLEITENDER BLOCK	GOUJON	TACO	
68	19.01.0008	1	VITE	SCREW	SCHRAUBE	VIS	TORNILLO	
69	07.14.1118	1	PERNO	PIN	BOLZEN	GOUPILLE	PASADOR	
70	19.02.0022	1	DADO	NUT	MUTTER	ECROU	TUERCA	
71	07.14.1115	1	PERNO	PIN	BOLZEN	GOUPILLE	PASADOR	
72	19.01.0314	2	VITE	SCREW	SCHRAUBE	VIS	TORNILLO	
73	08.14.3013	2	RONDELLA	WASHER	SCHEIBE	RONDELLE	ARANDELA	
74	55.10.0021	2	COPIGLIA	WASHER	SCHEIBE	RONDELLE	ARANDELA	
75	07.14.1117	1	PERNO	PIN	BOLZEN	GOUPILLE	PASADOR	
76	49.02.0042	4	CUSCINETTO	BALL BEARING	EINGEDENK	ROULEMENT	COJENETE	
77	08.14.1911	2	DISTANZIALE	SPACER	ABSTANDSTUECK	ENTRETOISE	SEPARADOR	
78	13.92.0010	1	RULLO	ROLL	ROLLER	ROULEAU	RODILLO	
79	08.14.3043	1	RULLO	ROLL	ROLLER	ROULEAU	RODILLO	
80	49.02.0068	2	CUSCINETTO	BALL BEARING	EINGEDENK	ROULEMENT	COJENETE	
81	08.14.3084	1	PATTINO	LINING	GLEITENDER BLOCK	GOUJON	TACO	
82	08.14.3120	2	PATTINO	LINING	GLEITENDER BLOCK	GOUJON	TACO	
83	07.14.1117	1	PERNO	PIN	BOLZEN	GOUPILLE	PASADOR	
84	55.10.0021	2	COPIGLIA	SCREW	SCHRAUBE	VIS	TORNILLO	
85	07.14.1151	1	PERNO	PIN	BOLZEN	GOUPILLE	PASADOR	
86	19.01.0314	2	VITE	SCREW	SCHRAUBE	VIS	TORNILLO	
87	08.14.3013	2	RONDELLA	WASHER	SCHEIBE	RONDELLE	ARANDELA	
88	08.14.3011	1	PATTINO	LINING	GLEITENDER BLOCK	GOUJON	TACO	
89	13.92.0010	1	PATTINO	LINING	GLEITENDER BLOCK	GOUJON	TACO	
90	49.02.0068	2	CUSCINETTO	BALL BEARING	EINGEDENK	ROULEMENT	COJENETE	
91	08.14.3118	2	PATTINO	LINING	GLEITENDER BLOCK	GOUJON	TACO	
92	19.01.0021	18	VITE	SCREW	SCHRAUBE	VIS	TORNILLO	
							XTJ 32	TAV. 12



GRUPPO ORIENTAMENTO JIB
GROUP JIB
GRUPPE JIB
GROUPE JIB
GRUPO JIB

TAV. 13

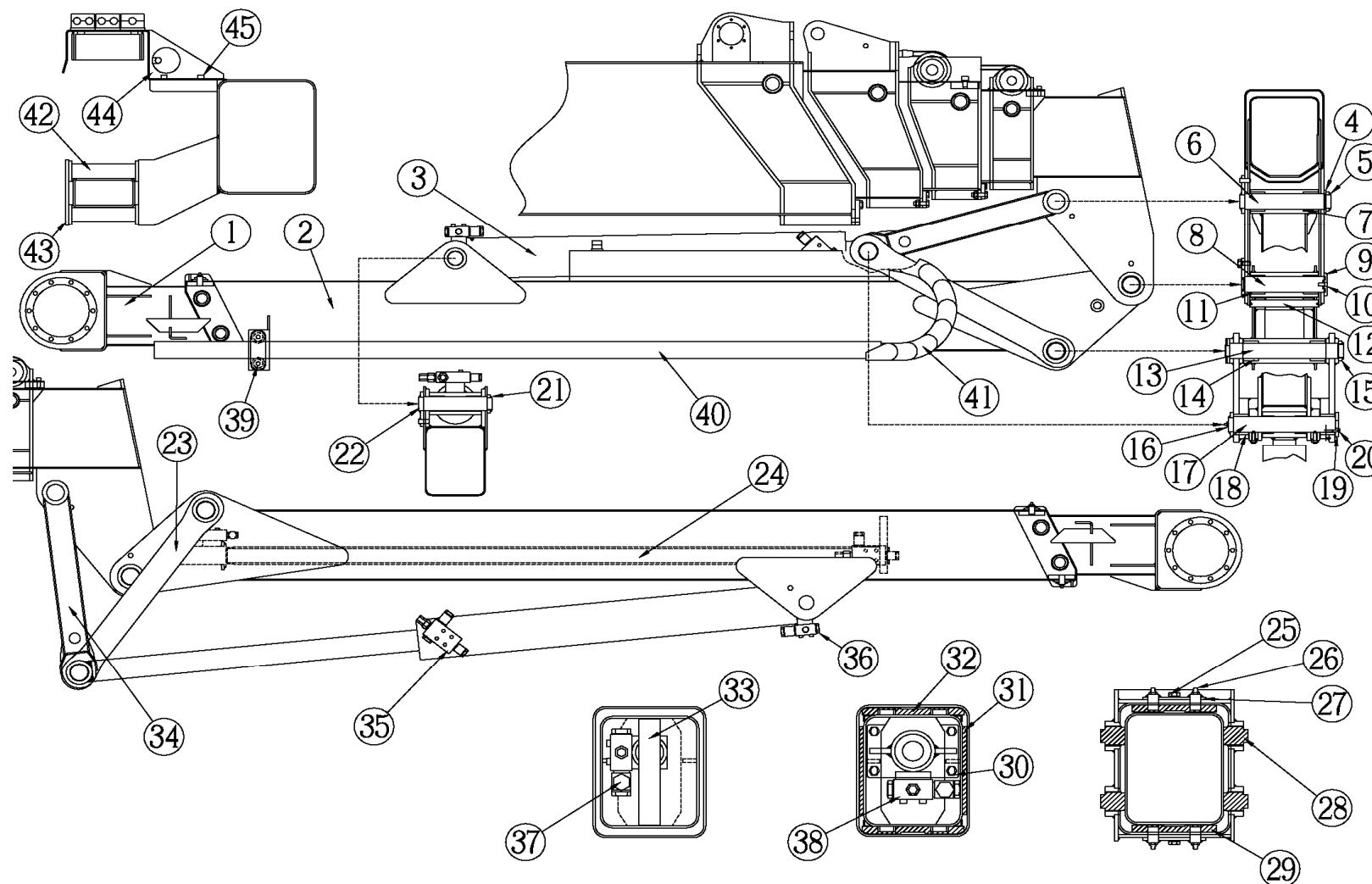



RIF	CODICE	N°	DESCRIZIONE	DESCRIPTION	BENNENNUNG	DESIGNATION	DENOMINACIONES	ANNOTAZIONI
1	05.92.0008	1	PROLUNGA JIB	JIB EXTENSION	ERWEITERUNG JIB	JIB RALLONGE	PROLONGA JIB	
2	05.14.1755	1	BRACCIO JIB	JIB BOOM	AUSLEGER JIB	BRAS PENDULAIRE	PLUMA JIB	
3	01.01.0831	1	CILINDRO ORIENT. JIB	JIB CYLINDER	ZYLINDER JIB	VERIN PENDULAIRE	CILINDRO JIB	
4	55.11.0026	1	RONDELLA	WASHER	SCHEIBE	RONDELLE	ARANDELA	
5	50.09.0060	1	GHIERA	WASHER	SCHEIBE	RONDELLE	ARANDELA	
6	07.14.1148	1	PERNO	PIN	BOLZEN	GOUPILLE	PASADOR	
7	08.14.2988	2	BOCCOLA	BUSH	BUCHSE	DOUILLE	BUJE	
8	07.14.1145	2	PERNO	PIN	BOLZEN	GOUPILLE	PASADOR	
9	08.14.3112	1	RONDELLA	WASHER	SCHEIBE	RONDELLE	ARANDELA	
10	19.01.0238	1	VITE	SCREW	SCHRAUBE	VIS	TORNILLO	
11	08.14.2988	2	BOCCOLA	BUSH	BUCHSE	DOUILLE	BUJE	
12	07.14.1146	1	PERNO	PIN	BOLZEN	GOUPILLE	PASADOR	
13	07.14.1147	1	PERNO	PIN	BOLZEN	GOUPILLE	PASADOR	
14	08.14.2988	2	BOCCOLA	BUSH	BUCHSE	DOUILLE	BUJE	
15	50.09.0060	1	GHIERA	WASHER	SCHEIBE	RONDELLE	ARANDELA	
16	55.14.0002	2	INGRASSATORE	GREASE FITTING	FETT-NIPPEL	GRAISSEUR	ENGRASADOR	
17	07.14.1150	1	PERNO	PIN	BOLZEN	GOUPILLE	PASADOR	
18	08.14.2988	2	BOCCOLA	BUSH	BUCHSE	DOUILLE	BUJE	
19	08.14.3113	1	RONDELLA	WASHER	SCHEIBE	RONDELLE	ARANDELA	
20	19.01.0231	3	VITE	SCREW	SCHRAUBE	VIS	TORNILLO	
21	50.09.0059	1	GHIERA	WASHER	SCHEIBE	RONDELLE	ARANDELA	
22	07.14.1149	1	PERNO	PIN	BOLZEN	GOUPILLE	PASADOR	
23	05.14.1756	1	TIRANTE	CONNECTING ROD	PLEUELTANGE	TIRANT	BIELA	
24	01.01.0615	1	CILINDRO SFILO JIB	RAM	ZYLINDER	VERIN	CILINDRO	
25	19.01.0016	2	VITE	SCREW	SCHRAUBE	VIS	TORNILLO	
26	55.14.0005	4	INGRASSATORE	GREASE FITTING	FETT-NIPPEL	GRAISSEUR	ENGRASADOR	
27	08.14.3110	2	STAFFA	SUPPORT	LAGERUNG	SUPPORT	SOSTEN	
28	08.14.3115	4	PATTINO	LINING	GLEITENDER BLOCK	GOUJON	BLOQUE QUE RESBALA	
29	08.14.3114	2	PATTINO	LINING	GLEITENDER BLOCK	GOUJON	BLOQUE QUE RESBALA	
30	19.01.0017	4	VITE	SCREW	SCHRAUBE	VIS	TORNILLO	
31	13.92.0003	2	PATTINO	LINING	GLEITENDER BLOCK	GOUJON	SOSTEN	



GRUPPO ORIENTAMENTO JIB
GROUP JIB
GRUPPE JIB
GROUPE JIB
GRUPO JIB

TAV. 13

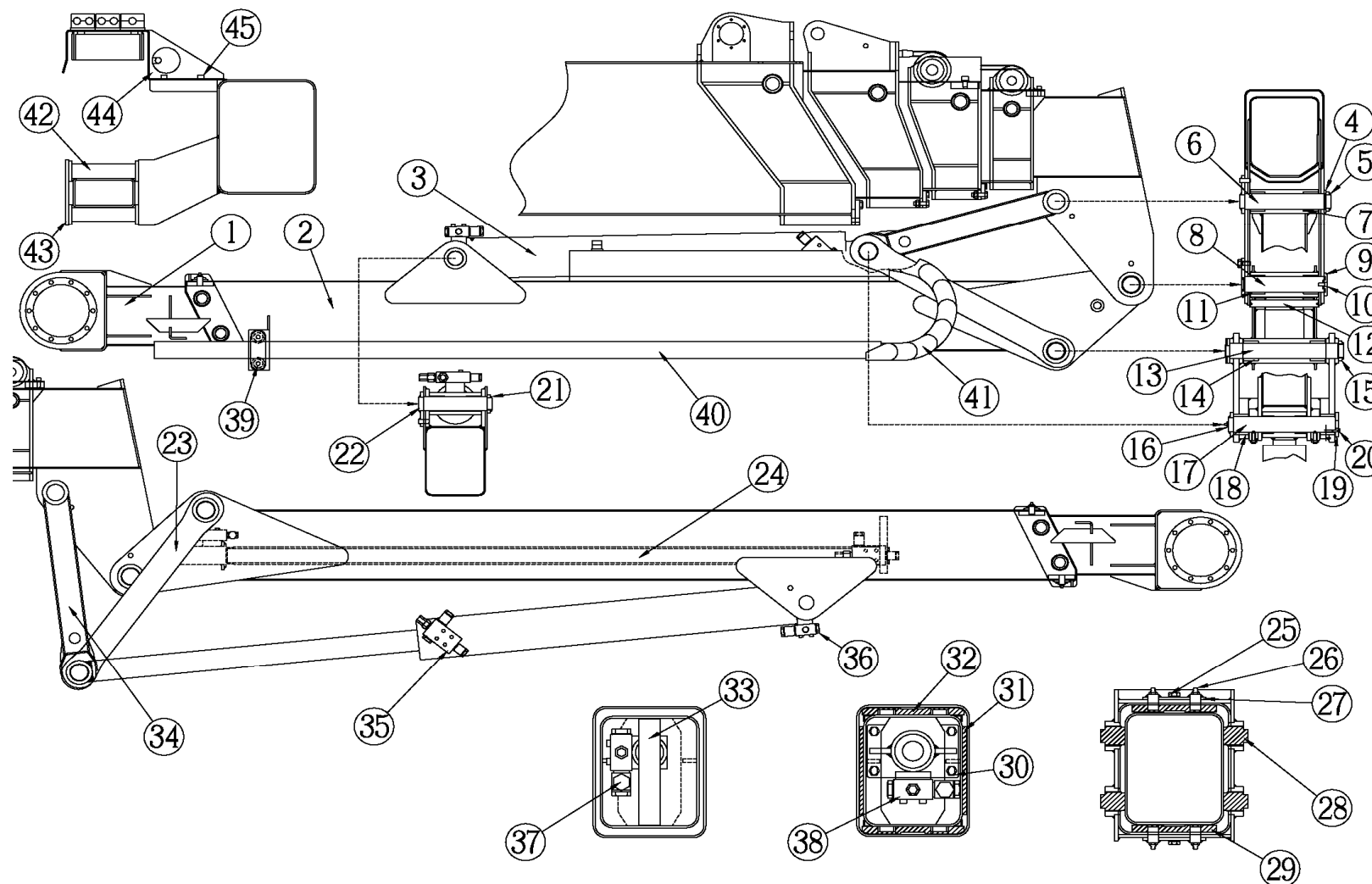



RIF	CODICE	N°	DESCRIZIONE	DESCRIPTION	BENNENNUNG	DESIGNATION	DENOMINACIONES	ANNOTAZIONI
32	08.14.3111	2	PATTINO	LINING	GLEITENDER BLOCK	GOUJON	BLOQUE QUE RESBALA	
33	08.14.3116	1	PATTINO	LINING	GLEITENDER BLOCK	GOUJON	BLOQUE QUE RESBALA	
34	05.14.1757	1	TIRANTE	CONNECTING ROD	PLEUELTANGE	TIRANT	BIELA	
35	/	1	VALVOLA	VALVE	VENTIL	VALVE	VALVULA	
36	/	1	VALVOLA	VALVE	VENTIL	VALVE	VALVULA	
37	/	1	VALVOLA	VALVE	VENTIL	VALVE	VALVULA	
38	/	1	VALVOLA	VALVE	VENTIL	VALVE	VALVULA	
39	08.14.1158	2	PERNO	PIN	BOLZEN	GOUPILLE	PASADOR	
40	08.14.2143	1	TUBOLARE	TUBULAR	TUBULÄRE	TUBOLAIRE	TUBULAR	
41	55.28.0388	/	CATENARIA	CHAIN	KETTE	CHAINE	CADENA	
42	08.14.1159	2	RULLO	ROLL	ROLLER	ROULEAU	RODILLO	
43	08.14.1157	1	PIATTO	SUPPORT	LAGERUNG	SUPPORT	SOSTEN	
44	08.14.2996	1	PIATTO	SUPPORT	LAGERUNG	SUPPORT	SOSTEN	
45	19.01.0231	4	VITE	SCREW	SCHRAUBE	VIS	TORNILLO	
							XTJ 32	TAV. 13

GRUPPO CESTO
GROUP CAGE
GRUPPE WARENKORB
GROUPE NACELLE
GRUPO QUERDA

TAV. 14

 XTJ 32

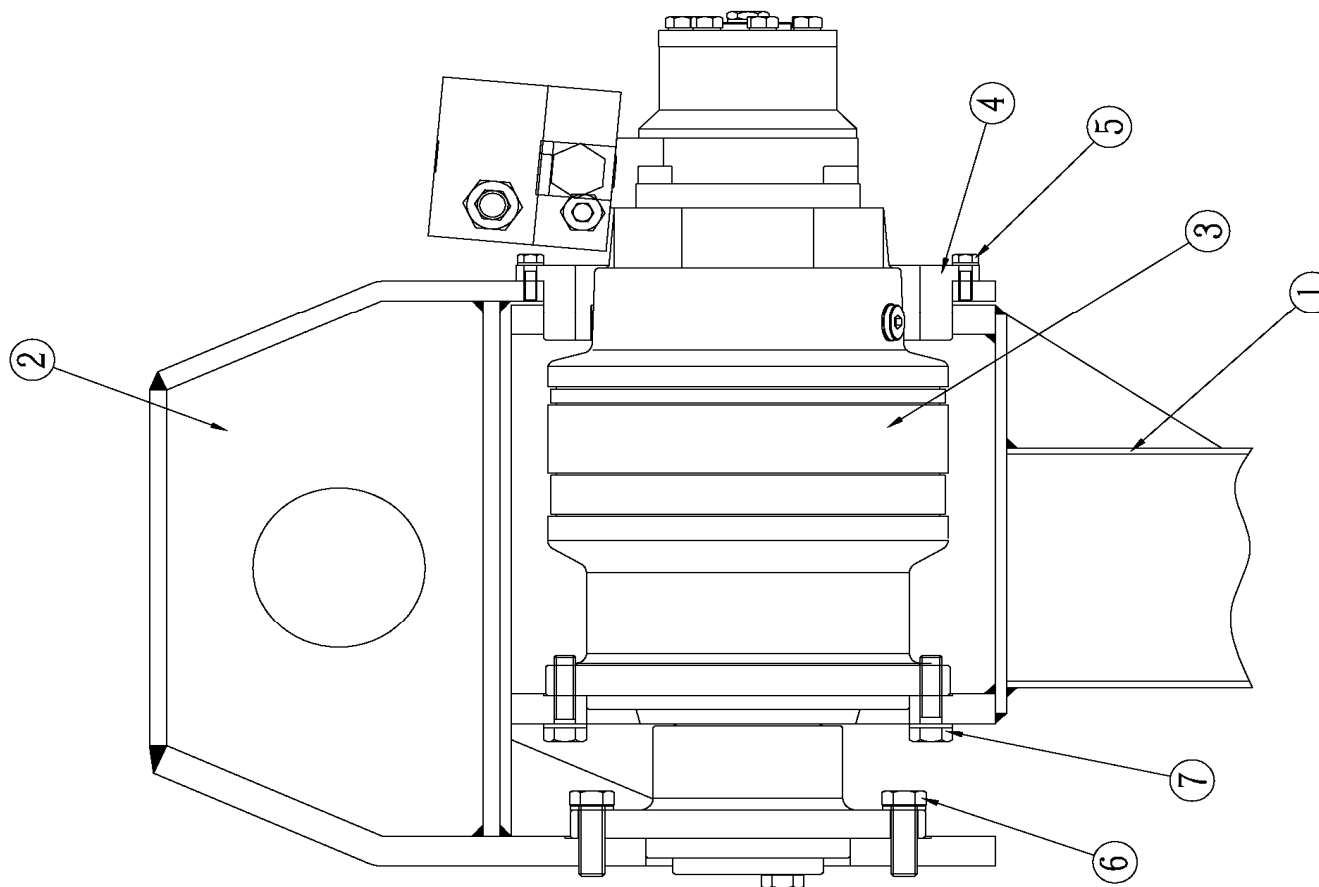



RIF	CODICE	N°	DESCRIZIONE	DESCRIPTION	BENNENNUNG	DESIGNATION	DENOMINACIONES	ANNOTAZIONI
1	05.14.1755	1	BRACCIO JIB	JIB BOOM	AUSLEGER JIB	BRAS JIB	PLUMA JIB	
2	05.77.0001	1	SUPPORTO	SUPPORT	LAGERUNG	SUPPORT	SOSTEN	
3	55.28.0716	1	RIDUTTORE	SLEWING OIL	MOTOR	ENGRANAGE ROTATION	MOTOR	
4	13.77.0003	1	FLANGIA	SUPPORT	LAGERUNG	SUPPORT	SOSTEN	
5	19.01.0003	8	VITE	SCREW	SCHRAUBE	VIS	TORNILLO	
6	19.01.0051	12	VITE	SCREW	SCHRAUBE	VIS	TORNILLO	
7	19.01.0035	10	VITE	SCREW	SCHRAUBE	VIS	TORNILLO	
							XTJ 32	TAV. 14



GRUPPO CESTO
GROUP CAGE
GRUPPE WARENKORB
GROUPE NACELLE
GRUPO QUERDA

TAV. 14

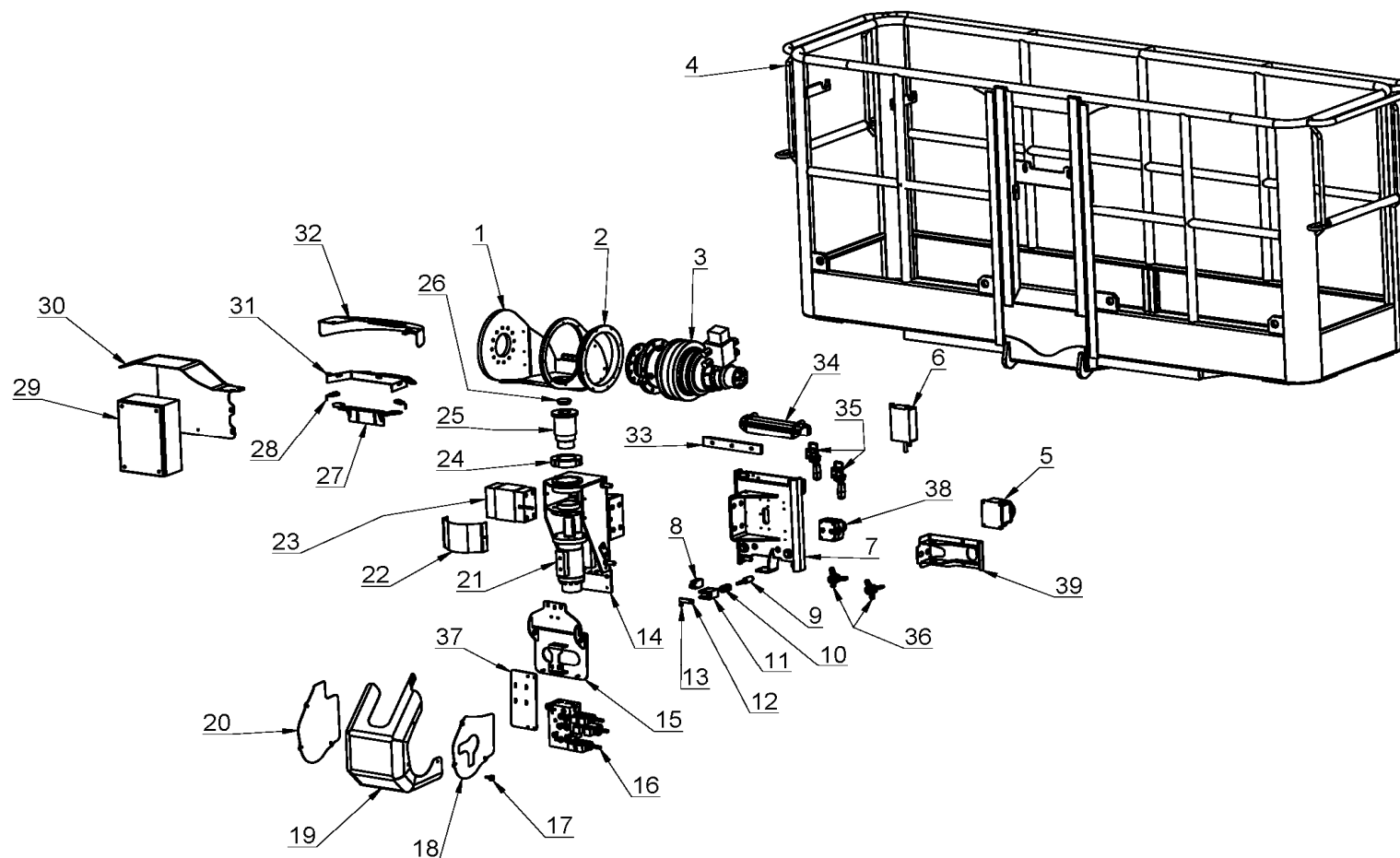



RIF	CODICE	N°	DESCRIZIONE	DESCRIPTION	BENNENNUNG	DESIGNATION	DENOMINACIONES	ANNOTAZIONI
1	05.103.0023	1	SUPPORTO	SUPPORT	LAGERUNG	SUPPORT	SOSTEN	
2	13.110.0149	1	FLANGIA	BRIDE	FLANSCH	FLANGE	PLETINA	
3	/	1	RIDUTTORE	SLEWING OIL	MOTOR	ENGRANAGE ROTATION	MOTOR	
4	05.101.0011	1	CESTO	CAGE	WARENKORB	NACELLE	QUERDA	
5	14.12.1273B	1	PRESA 230V	BOX 230V	BOX 230V	BOX 230V	BOX 230V	
6	/	1	INTERFONICO	BOX	BOX	BOX	BOX	
7	05.103.0042	1	SUPPORTO ATTACCO	SUPPORT	LAGERUNG	SUPPORT	SOSTEN	
8	/	1	FINECORSIA	PROXIMITY	PROXIMITY	PROXIMITY	PROXIMITY	
9	13.92.0002B	1	PERNO	PIN	BOLZEN	GOUPILLE	PASADOR	
10	55.13.0036	24	MOLLA A TAZZA	WASHER	SCHEIBE	RONDELLE	ARANDELA	
11	13.92.0002A	1	MASSELLO	SUPPORT	LAGERUNG	SUPPORT	SOSTEN	
12	13.92.0002C	1	PIATTO	SUPPORT	LAGERUNG	SUPPORT	SOSTEN	
13	19.02.0004	1	DADO	NUT	MUTTER	ECROU	TUERCA	
14	05.14.1848	1	SUPPORTO CESTO	SUPPORT	LAGERUNG	SUPPORT	SOSTEN	
15	13.103.0203	1	SUPPORTO	SUPPORT	LAGERUNG	SUPPORT	SOSTEN	
16	/	1	DISTRIBUTORE	CONTROL VALVE	STEUERVENTIL	DISTRIBUTEUR	DISTRIBUDOR	
17	55.03.0173	6	VOLANTINO	SCREW	SCHRAUBE	VIS	TORNILLO	
18	13.103.0379	1	LAMIERA LATERALE	SUPPORT	LAGERUNG	SUPPORT	SOSTEN	
19	13.92.0020	1	LAMIERA LATERALE	SUPPORT	LAGERUNG	SUPPORT	SOSTEN	
20	13.92.0022	1	CARTER	COVER	DECKEL	COUVERCLE	CUBIERTA	
21	/	1	ATTUATORE	ACTUATOR	MOTOR	MOTEUR	MOTOR	
22	08.14.2717	1	CARTER	COVER	DECKEL	COUVERCLE	CUBIERTA	
23	/	1	CELLA MOBA	CELL	ZELLE	CELLULE	CELULA	
24	08.14.2315	1	GHIERA	WASHER	SCHEIBE	RONDELLE	ARANDELA	
25	08.14.2314	1	ALBERO	GEAR	WELLE	PIVOT	ARBOL	
26	08.14.2610	1	TAPPO	COVER	DECKEL	COUVERCLE	CUBIERTA	
27	13.110.0152	1	SUPPORTO	SUPPORT	LAGERUNG	SUPPORT	SOSTEN	
28	/	2	PROXIMITY	PROXIMITY	PROXIMITY	PROXIMITY	PROXIMITY	
29	/	1	CASSETTA	ELECTRIC BOX	ELECTRIC BOX	ELECTRIC BOX	ELECTRIC BOX	
30	13.101.0085	1	SUPPORTO	SUPPORT	LAGERUNG	SUPPORT	SOSTEN	
							XTJ 32	TAV. 14



GRUPPO CESTO
GROUP CAGE
GRUPPE WARENKORB
GROUPE NACELLE
GRUPO QUERDA

TAV. 14

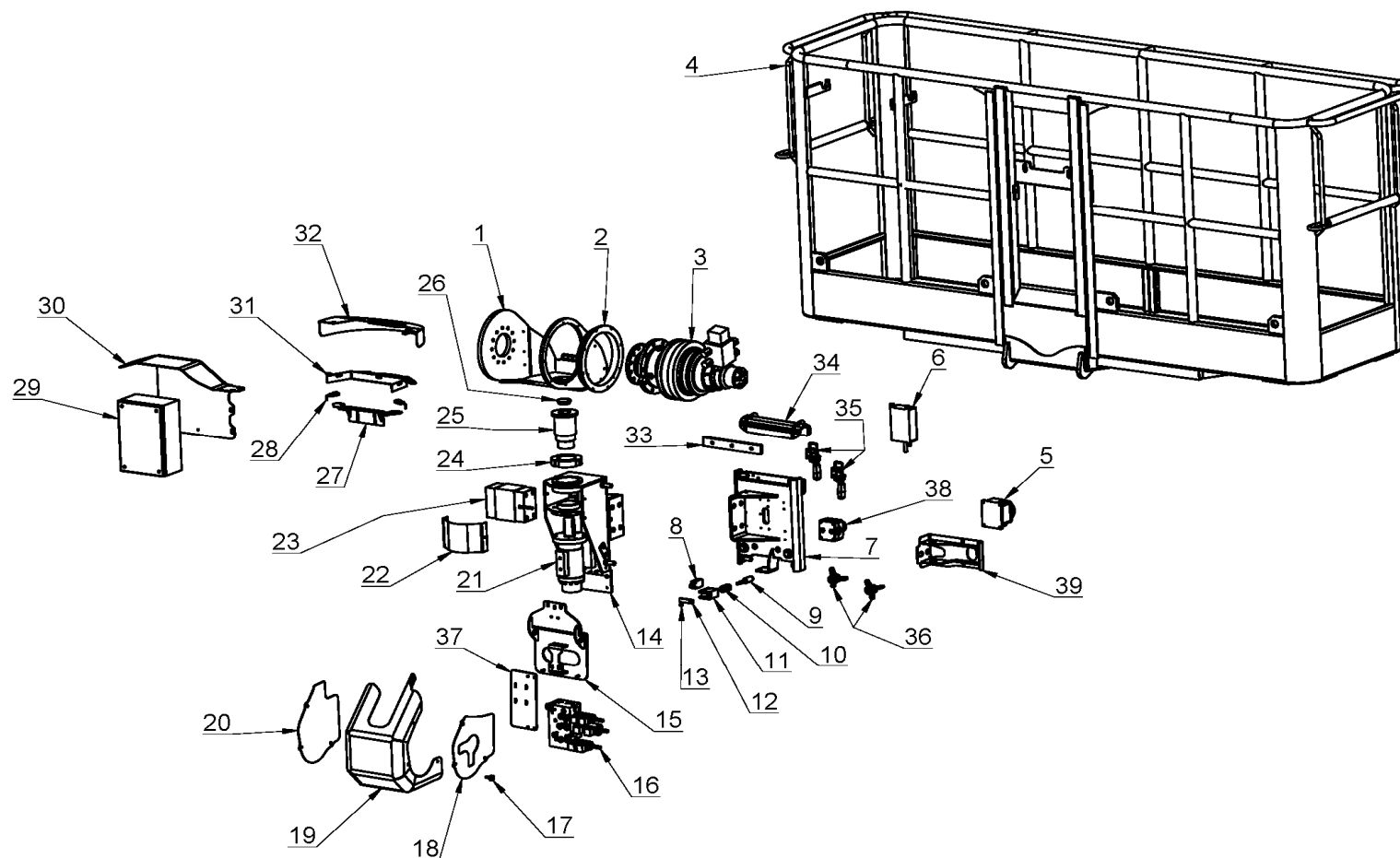



RIF	CODICE	N°	DESCRIZIONE	DESCRIPTION	BENNENNUNG	DESIGNATION	DENOMINACIONES	ANNOTAZIONI
31	13.110.0151	1	SUPPORTO	SUPPORT	LAGERUNG	SUPPORT	SOSTEN	
32	13.110.0153	1	SUPPORTO	SUPPORT	LAGERUNG	SUPPORT	SOSTEN	
33	13.103.0274	1	PATTINO	LINING	GLEITENDER BLOCK	GOUJON	TACO	
34	13.103.0273	1	SUPPORTO	SUPPORT	LAGERUNG	SUPPORT	SOSTEN	
35	55.03.0477	2	MANIGLIA	SCREW	SCHRAUBE	VIS	TORNILLO	
36	55.03.0425	2	POMELLO	SCREW	SCHRAUBE	VIS	TORNILLO	
37	13.103.0380	1	SUPPORTO	SUPPORT	LAGERUNG	SUPPORT	SOSTEN	
38	/	1	STOP EMERGENZA	EMERGENCY BUTTON	EMERGENCY BUTTON	ARRÊT D'URGENCE	PARADA DE EMERGENCIA	
39	13.103.0360	1	SUPPORTO	SUPPORT	LAGERUNG	SUPPORT	SOSTEN	



RAGNO XTJ32
ELECTRICAL DIAGRAM 0021920009 REV.D

NAME	DESCRIPTION
B	BUZZER ON THE BASKET CONTROL PANEL
B1	BUZZER MOTOR OVERTEMPERATURE
EV1	GENERATOR ELECTROVALVE
EV3	OIL TO THE GROUND / BOOM ELECTROVALVE
EV6	OIL TO STABILIZER ELECTROVALVE
EV8	THIRD SPEED ELECTROVALVE
EV9	DRAIN OIL ELECTROVALVE
EV10	OIL TO THE BASKET ELECTROVALVE
EV11A	STABILIZER 1 LIFTING ELECTROVALVE
EV11B	STABILIZER 3 LOWERING ELECTROVALVE
EV12A	STABILIZER 2 LIFTING ELECTROVALVE
EV12B	STABILIZER 3 LOWERING ELECTROVALVE
EV13A	STABILIZER 3 LIFTING ELECTROVALVE
EV13B	STABILIZER 3 LOWERING ELECTROVALVE
EV14A	STABILIZER 4 LIFTING ELECTROVALVE
EV14B	STABILIZER 4 LOWERING ELECTROVALVE
EV15	BASKET ROTATION ELECTROVALVE
EV16	BASKET LEVELLING ELECTROVALVE
EV17	ELECTROVALVE EXTENSION/RETRACTION JIB
EV23	DRAIN OIL ELECTROVALVE
EV26A	TURNTABLE ROTATION DRAIN OIL ELECTROVALVE (DIRECTION A)
EV26B	TURNTABLE ROTATION DRAIN OIL ELECTROVALVE (DIRECTION B)
FE2	BATTERY PROTECTION FUSE 50A
FE1	EMERGENCY PUMP PROTECTION FUSE 2 A
FE	POWER LINE FOR DIESEL MOTORE AND EMERGENCY PUMP FUSE 225A
F0A	KUBOTA BOX FUSE 35A
F0B	KUBOTA BOX FUSE 30A
F0C	KUBOTA BOX FUSE 7.5A
FA	MAIN 12V FUSE 30A
F	MAIN 24V FUSE – 15A
F1	MAIN FUSE – 10A
F2	FRAME LINE FUSE – 10 A
F3	TURRET LINE FUSE 5A
F4	JIB LINE FUSE 7.5 A
F5	DISTRIBUTOR LINE FUSE 7.5 A
F7A	INTERCOM PROTECTION FUSE – 4A
F7B	INTERCOM PROTECTION FUSE – 4A
F8	FUSE EV9-RFID-EV23 FEEDBACK
FC1	STABILIZER 1 ON THE GROUND LIMIT SWITCH
FC2	STABILIZER 2 ON THE GROUND LIMIT SWITCH
FC3	STABILIZER 3 ON THE GROUND LIMIT SWITCH
FC4	STABILIZER 4 ON THE GROUND LIMIT SWITCH
FC5	STABILIZER 1 PIN LIMIT SWITCH
FC6	STABILIZER 2 PIN LIMIT SWITCH
FC7	STABILIZER 3 PIN LIMIT SWITCH
FC8	STABILIZER 4 PIN LIMIT SWITCH
FC9	STABILIZER 1 LARGE POSITION LIMIT SWITCH
FC10	STABILIZER 2 LARGE POSITION LIMIT SWITCH
FC11	STABILIZER 3 LARGE POSITION LIMIT SWITCH
FC12	STABILIZER 4 LARGE POSITION LIMIT SWITCH
FC13	NOTABLE POINT LIMIT SWITCH
FC14	BASKET CONNECTED MICRO SWITCH
FC16	STABILIZER 1 INCLINATION LIMITSWITCH
FC17	STABILIZER 2 INCLINATION LIMITSWITCH
FC18	STABILIZER 3 INCLINATION LIMIT SWITCH
FC19	STABILIZER 4 INCLINATION LIMIT SWITCH
FCFOOT	FOOT PEDAL MICRO SWICTH
KE	EMERGENCY PUMP CONTACTOR
K1	GENERATOR RELAY
K2	MAIN RELAY
K3	STARTING ELECTRICAL MOTORS RELAY
KMOT	RELAY MOTOR STATUS OFF/ON



L1	ALARMS / OUTRIGGERS LAMP ON THE MAIN ELECTRICAL BOX
L11	ALTERNATOR LAMP
L12	OIL MOTOR LAMP
L13	SPARKPLUG LAMP
PE	EMERGENCY PUMP BUTTON
P1	EMERGENCY BUTTON ON THE MAIN ELECTRICAL BOX
P2	FN BUTTON
P3	EMERGENCY BUTTON ON THE BASKET CONTROL PANEL
P4	EMERGENCY BUTTON FIXED IN THE BASKET
PRX4	PROXIMITY CAGE IN THE CENTER
PRX4A	PROXIMITY CAGE IN THE CENTER
PRXEV9	PROXIMITY FEEDBACK EV9
S1	KEY MOVEMENTS SELECTOR
S2	DIRECT STABILIZATION SELECTOR
S3	AUTOMATIC / MANUAL STABILIZATION SELECTOR
MA1	LEFT JOYSICK ON THE BASKET CONTROL PANEL
MA2	RIGHT JOYSTICK ON THE BASKET CONTROL PANEL
PR1	PRESSURE SENSOR EV23

ELECTRONIC DEVICES

NAME	DESCRIPTION
F2P	FLOWCONTROL-2P
SMARTCONTROL	CANBUS DISTRIBUTOR TURRET/FRAME
MODULBOX 0X150	MODULBOX IN THE MAIN ELECTRICAL BOX
MODULBOX 0X153	MODULBOX IN THE JIB ELECTRICAL BOX
ALFABETA FENICE	ANGLE SENSOR ON THE CHASSIS
TRAFFIC LIGHT	LIGHT GREEN/YELLOW/RED ON THE TURRET
OPUS	DISPLAY
ASM WBT85	EXTENSION + ANGLE SENSOR ON THE BOOM
RADIO	REMOTE CONTROL PANEL
ECU10	BASKET LEVELLING DEVICE
ENC.A	TUIRNTABLE ENCODER A
ENC.B	TUIRNTABLE ENCODER B
C1	INTERFONICO ON THE GROUND
C2	INTERFONICO ON THE BASKET
LOAD CELL	LOAD SENSOR MOBA
GEFRAN JIB	INCLINOMETER SENSOR ON THE JIB
INVERTER 230V	CONTROLLER FOR THE RPM OF THE 230V MOTOR

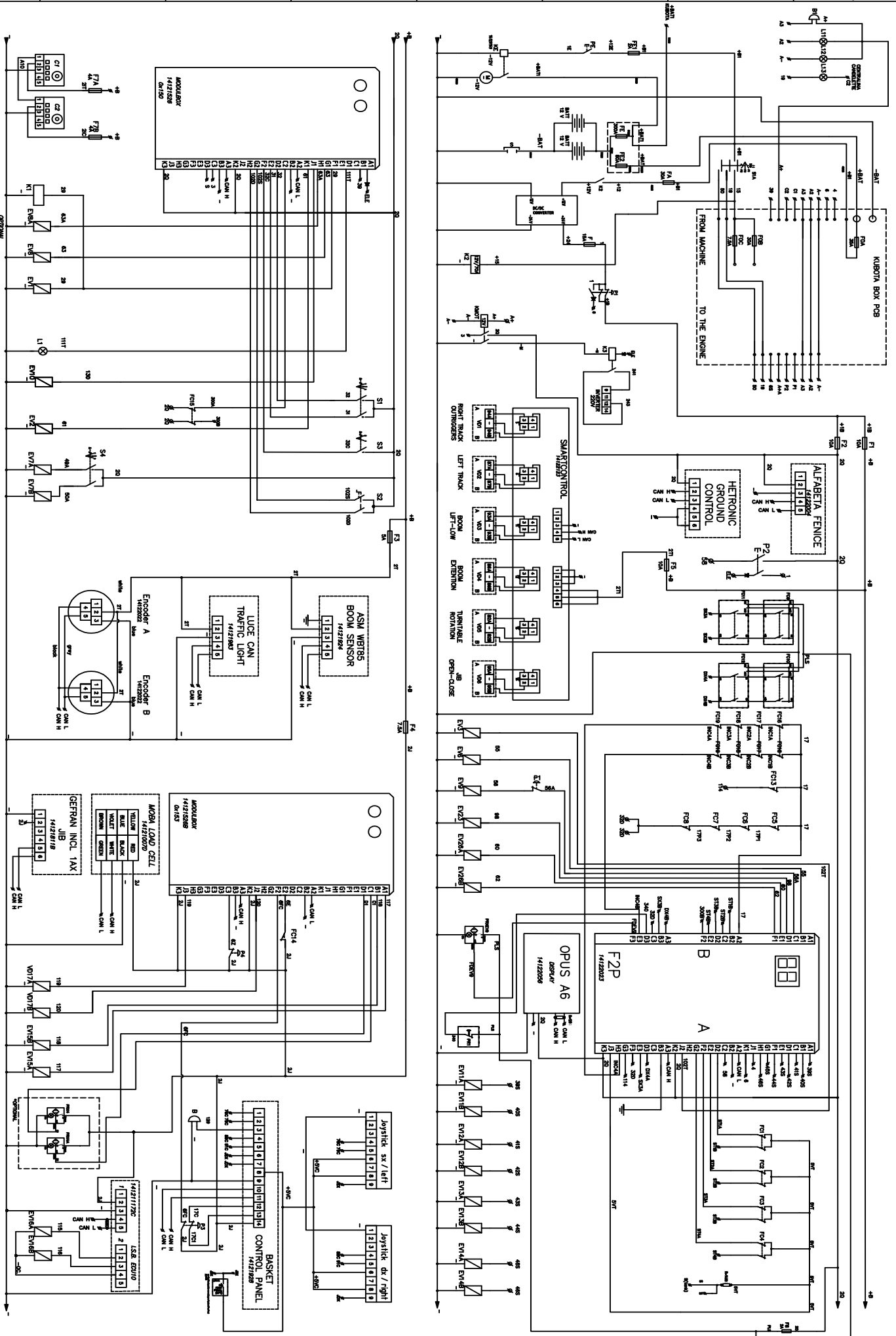

1: brown, 2: white, 3: blue, 4: black, 5: grey

Palazzani Industrie s.p.a.
 Via del Lavoro 10
 41013 Montebelluna (TV) - Italy
 Tel. +39 0422 770001
 Fax +39 0422 770002
 Email: info@palazzani.it

Schema elettrico :
 RAGNO XT320C KUBOTA

Disegn.: C/ID/4
 Data: 27/07/2023

Rev. 0021920009 Rev.D

La Palazzani Industrie s.p.a. si riserva il diritto di modificare senza preavviso le specifiche tecniche e i prezzi senza alcun preavviso.

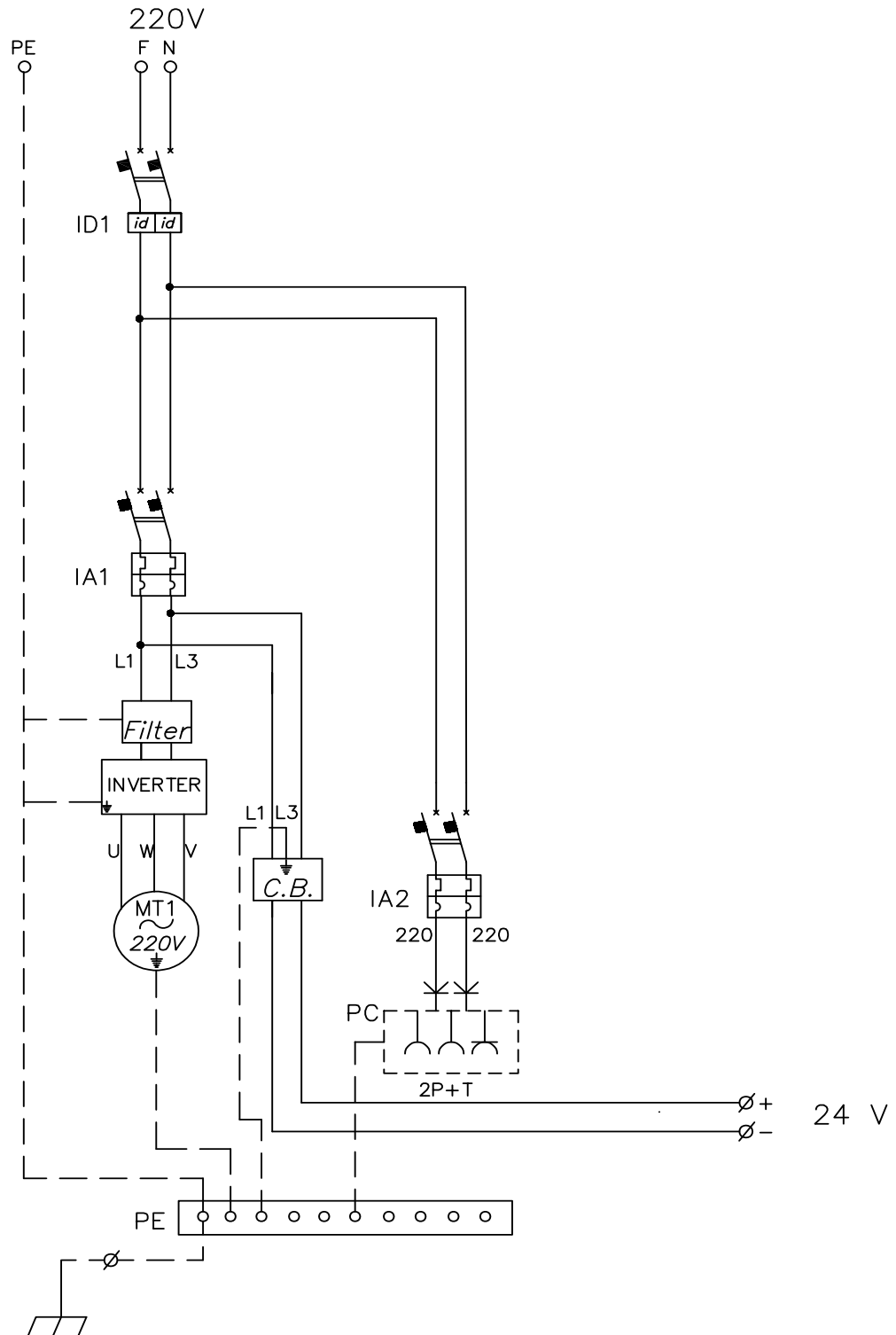

Palazzani Industrie s.p.a.

Via del Pavione n.4 25050 Paderno F.C. (Brescia)
tel. 030/6857073 Fax:030/657079
Mailto: info@palazzani.it www.palazzani.it

Dis. N°

0002192005

Schema elettrico :

Circuito di potenza 220V con inverter

Diseg. Cajola M.

Controll. _____

Data 29/05/18

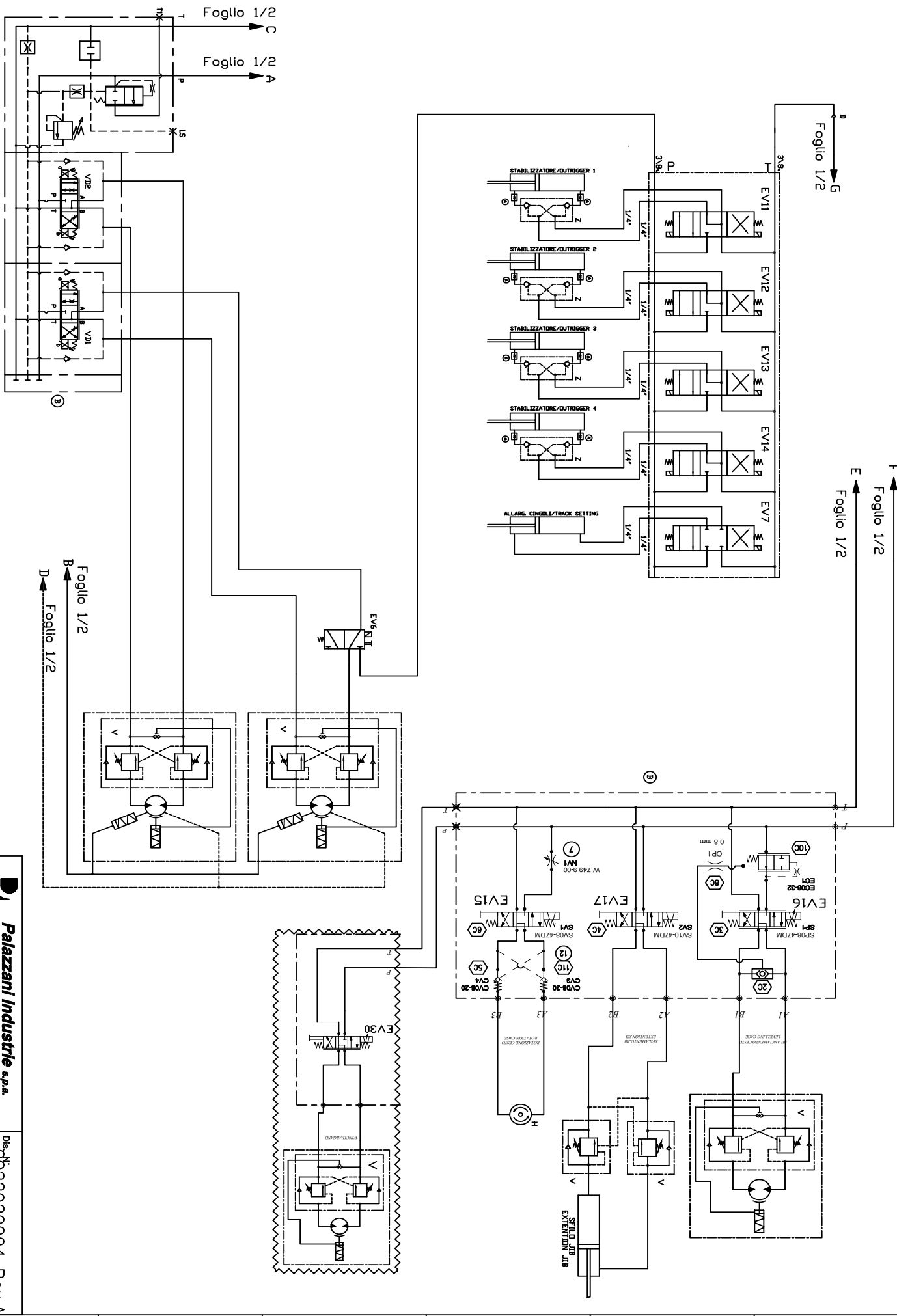

Palazzani Industrie s.p.a.
 Via del Pavone n.4 20090 Paderno F.C. (Brescia)
 Tel. 030/9657073 Fax 030/957079
 Mail: info@palazzani.it www.palazzani.it

Schema idraulico : RAGNO XTJ327C KUBOTA

Dis. N° 022920004 Rev. A
 Foglio 2/2

Disegn. C. J. M.
 Control. M. M.
 Data 18/05/2022

La PALAZZANI INDUSTRIE S.p.A. si riserva o i termini di legge la proprietà del presente disegno con diritto di riproduzione o comunque a terzi senza sua autorizzazione.



NOTE

A series of 18 horizontal dotted lines for writing notes.



Palazzani INDUSTRIE

Via del Pavione,4 – 25050 PADERNO F.C. (BS) – ITALY
Tel. ++39 030 6857073 – Fax ++39 030 657079
Mailto: info@palazzani.it - www.palazzani.it